

Service Bulletin

Title: Conversion of 429EC-202-1/-3 **Single** Evaporator System to 429EC-200-5 **Dual** Evaporator System

Date: March 27, 2012

Applicability: BHT M429 helicopters equipped with 429EC-202-3 ACC Air Conditioning Systems (S/N 57052 and subsequent) and helicopters equipped with 429EC-202-1 ACC Air Conditioning Systems (S/N 57001 – 57051).

Prerequisite: BHT TB 429-11-12 must be performed prior to installation of this service bulletin for helicopter serial numbers 57001 – 57051.

- Reference:**
1. F.A.A. /S.T.C. # SR00693DE, Bell Helicopter 429 Series Air Conditioning System
 2. Single Forward Evaporator Installation Drawing 429EC-602
 3. Dual Forward Evaporator Installation Drawing 429EC-600
 4. Single Aft Evaporator Installation Drawing 429EC-624
 5. Dual Aft Evaporator Installation Drawing 429EC-622
 6. Single Evaporator Plumbing Installation Drawing 429EC-522
 7. Dual Evaporator Plumbing Installation Drawing 429EC-500
 8. Single Evaporator Electrical Installation Drawing 429EC-812
 9. Dual Evaporator Electrical Installation Drawing 429EC-810
 10. Single Evaporator Air Distribution Installation Drawing 429EC-682
 11. Dual Evaporator Air Distribution Installation Drawing 429EC-680

Compliance: At the discretion of the operator

A. Discussion

This Bulletin authorizes the change of the top drawing from 429EC-202-3 Single Evaporator System equipped with Allied motors to the 429EC-200-5 Dual Evaporator System equipped with Allied motors.

B. Manpower

Approximately 90 man-hours are required to complete the service bulletin (May vary with personnel and facilities available).

C. Warranty

There is no warranty credit applicable for parts or labor associated with this bulletin.

D. Approval

The technical aspects of this service bulletin are based on FAA approved data.

Revision	Issue Date	Written By	Approved	Description of Change
N/C	3/27/12	RL		Initial Release

E. Weight & Balance

Once installed, the new weight and balance for the dual system will be as follows:

Item	Weight (lb)	X-Arm (in)	Y-Arm (in)	X-M (in-lb)	Y-M (in-lb)
Dual Evaporator Installation					
Total (English Units)	113.3	176.5	-2.4	19,998	-271
Total (Metric Units)	51.4	4,483.4	-60.7	230,402	-3121

F. Material

Items to be Removed:

Qty	Part Number	Nomenclature
	Forward Evaporator, LH	
1	429EC-6012-2	Duct Assembly, RH Dual Elbow
1	429EC-6012-3	Duct Assembly, Flexible
2	MS21919WCH8	Clamp, Loop
1	MS21919WCH14	Clamp, Loop
3	MS21919WCH56	Clamp, Loop
2	CP-25-50B	Ty-Wrap
	Plumbing – Aft Evaporator, LH	
1	427EC-5060-T37	Plug, #6
1	429EC-5020-T34	Tube Assembly
3	MS21919WDG11	Clamp
1	NAS43DD3-28FC	Spacer
1	MS27039-1-15	Screw
2	MS27039-1-08	Screw
3	MS21042L3	Nut, Self-locking
3	NAS1149F0332P	Washer
	Plumbing – Fwd Evaporator	
1	429EC-5040-5	Hose Assembly
1	429EC-5040-6	Hose Assembly
2	MS21042L3	Nut, Self-locking
3	MS21919WDG10	Clamp
3	MS21919WDG12	Clamp
5	NAS1149D0332J	Washer
2	NAS1149F0332P	Washer
1	NAS1801-3-10	Screw
1	NAS1801-3-11	Screw
1	NAS1801-3-31	Screw
1	NAS43DD3-72FC	Spacer
1	MS9596-024	Bracket, Angle
	Electrical – Aft Evaporator, LH	
1	429EC-6214-3	Stowage Bracket Assembly
1	MS21919WDG4	Clamp
1	MS27039-1-07	Screw
2	NAS1149D0316J	Washer
1	MS21042L3	Nut

Items to be Installed:

Item	Qty	Part Number	Nomenclature
		Forward Evaporator, LH (Fig. 7, 8)	
10	1	S-6029EC-1	Evaporator Assembly, LH Fwd
1	1	429EC-6010-10	Duct Assembly, LH Elbow
2	1	429EC-6010-11	Duct Assembly, RH Elbow
7	1	429EC-6010-7	Duct Assembly, LH Flexible
9	1	429EC-6290-1	Drain Tube, LH Fwd Evap
12	1	S-6031EC-11	Support Bracket, Fwd Evap

14	1	S-6032EC-25	Mount, LH Fwd
16	1	S-6032EC-27	Mount, LH Aft
18	1	S-6066EC-6	Drain Tube ½ inch
20	4	AD42ABS	Rivet, Pop
21	5	AN3-4A	Bolt, Machine
22	6	MS27039-0806	Screw, Machine
23	1	MS27039-1-05	Screw, Machine
25	1	NAS1149D0332J	Washer
26	5	NAS1149F0332P	Washer
27	8	NAS1149FN416P	Washer
28	6	NAS1149FN832P	Washer
29	2	NAS1149D0363J	Washer
		Aft Evaporator, LH (Fig. 12, 13, 14, 15, 23, 24)	
	1	429EC-6302-3	Evaporator Assembly, LH Aft
3	2	429EC-6224-10	Shim
4	2	429EC-6224-11	Shim
5	1	429EC-7520-12	Mounting Bracket Back
7	1	429EC-7520-14	Mounting Bracket Front
9	1	S-6552EC-1	Check Valve Assembly
10	1	S-6554EC-1	Fitting Bulkhead, ½"
11	6	ES30043-2	Clamp, Hose
12	1	ES39340-2	Elbow, ½"
13	170"	ES48154-1	Hose, Drain
14	5	ES59110-4	Decal, 'Evaporator Water Drain'
15	4	AN3-3A	Bolt, Machine
16	5	AN3-5A	Bolt, Machine
17	1	AN924-8D	Nut, Plain Hexagon
22	8	MS21919WDG12	Clamp, Loop
24	1	MS35489-149	Grommet
26	3	NAS1149D1232J	Washer
27	9	NAS1149F0332P	Washer
		Plumbing – Aft Evaporator, LH (Fig. 16, 17, 18)	
7	1	429EC-5020-T9	Tube Assembly
10	1	429EC-5020-T12	Tube Assembly
33	1	ES40632-6D	Union, #6
54	2	ES44012-2	O-Ring
56	4	ES44012-3	O-Ring
41	1	S-5080EC-10	Y-Fitting Assembly
102	3	MS21919WDG11	Clamp
48	3	MS27039-1-08	Screw
51	3	MS21042L3	Nut, Self-locking
52	6	NAS1149F0332P	Washer
		Plumbing – Fwd Evaporator, LH (Fig. 9, 10)	
5	1	429EC-5020-T5	Tube Assembly
6	1	429EC-5020-T7	Tube Assembly
24	1	429EC-5030-H5	Hose Assembly
25	1	429EC-5030-H6	Hose Assembly
62	1	429EC-5040-1	Hose Assembly

61	1	429EC-5040-2	Hose Assembly
54	6	ES44012-2	O-Ring
56	6	ES44012-3	O-Ring
35	1	ES40634-6	T-Fitting, #6
36	1	ES40634-8	T-Fitting, #8
51	3	MS21042L3	Nut, Self-locking
63	3	MS21919WDG10	Clamp
64	3	MS21919WDG12	Clamp
71	6	NAS1149D0332J	Washer
76	1	NAS43DD3-72FC	Spacer
87	2	NAS1801-3-9	Screw
40	1	NAS1801-3-31	Screw
		Air Distribution – Aft Evap, LH (Fig. 19, 20, 21, 22)	
1	1	429EC-6810-1	Duct Assy, Adapter – Upr Return
2	1	429EC-6810-2	Duct Assy, Adapter – Lwr Return
3	1	429EC-6810-3	Duct Assy, Adapter – LH
5	1	429EC-6811-1	Duct Assy, One Way
6	1	429EC-6814-1	Duct Assy, Baffle – LH
8	1	429EC-6820-1	Duct Assy – Lwr Outlet
9	1	429EC-6820-2	Duct Assy – Upr Outlet
10	5	AN3-6A	Bolt
11	3	MS27039-08-08	Screw
12	4	MS27039-1-06	Screw
13	4	MS27039-1-07	Screw
14	4	MS27039C1-11	Screw
15	4	NAS1149C0332R	Washer
16	3	NAS1149FN832P	Washer
17	13	NAS1149F0332P	Washer
18	1	NAS520-34-10	Coupling
19	2	CP-25-50-B	Ty-Wrap
		Electrical – Aft Evaporator, LH (Fig. 25, 26, & 27)	
-	1	MS26574-15	Circuit Breaker
-	2	MS21919WDG4	Clamp
-	1	MS21919WDG8	Clamp
-	2	MS27039-1-08	Screw
-	2	NAS1149D0316J	Washer
-	1	MS21042L3	Nut, Self-locking

Overview

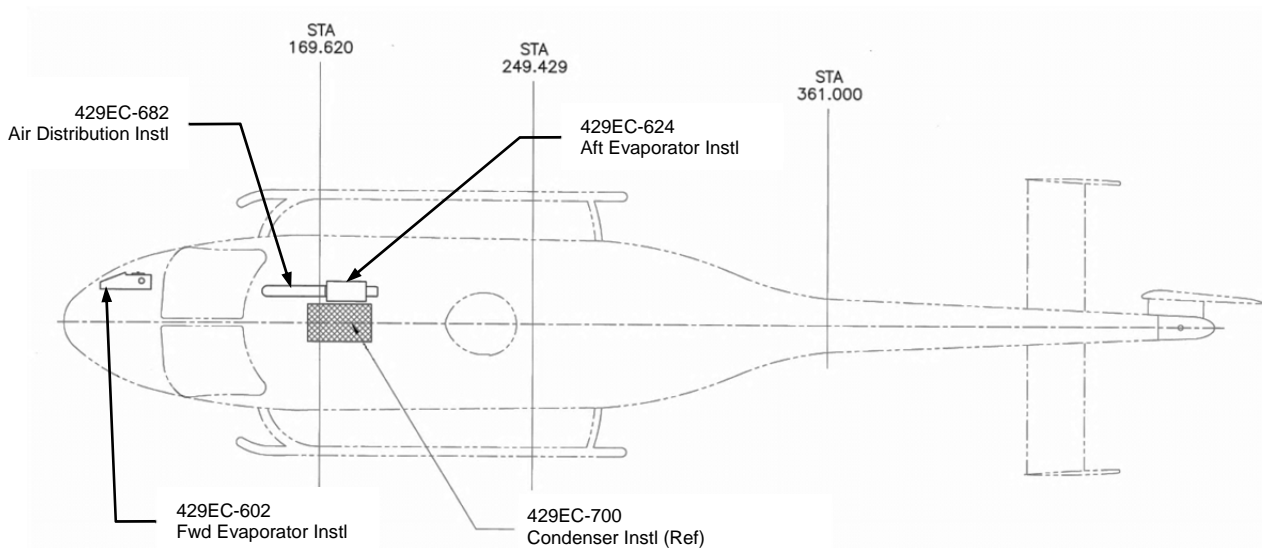

Figure 1: Air Conditioner Layout (Single Fwd/Aft Evaporators)

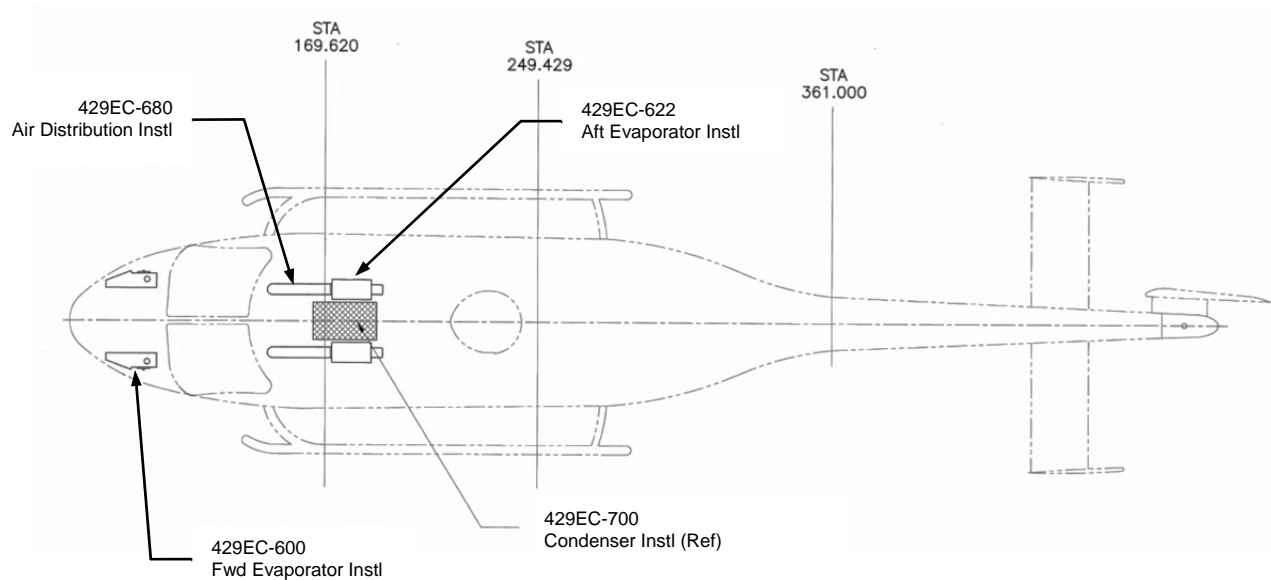

Figure 2: Air Conditioner Layout (Dual Fwd/Aft Evaporators)

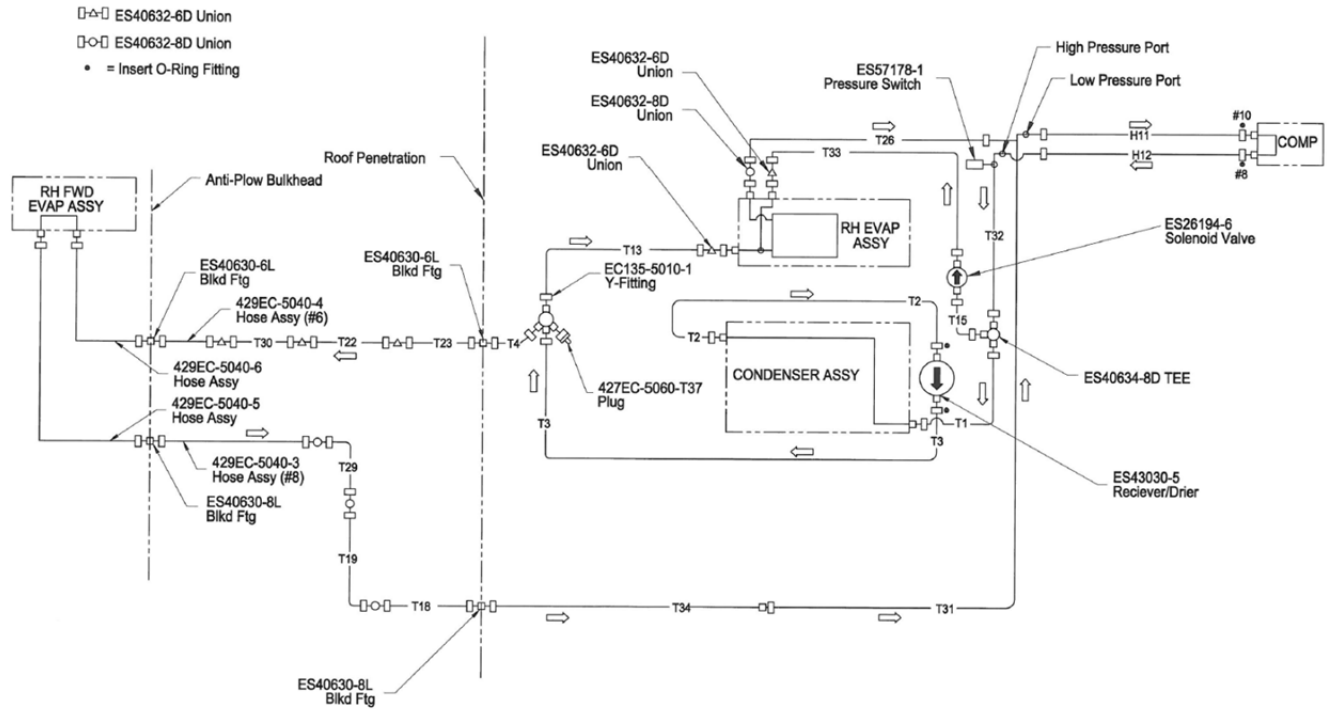

Figure 3: Air Conditioner Plumbing (Single Fwd/Aft Evaporators)

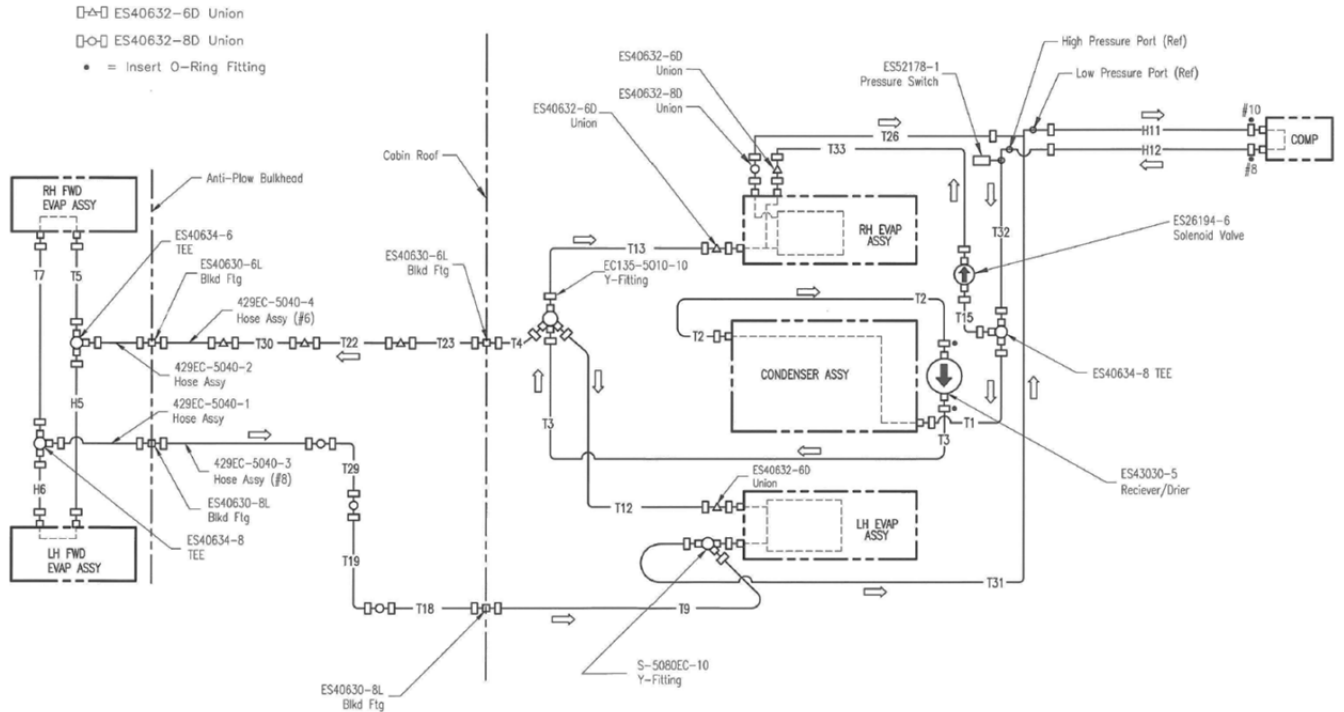

Figure 4: Air Conditioner Plumbing (Dual Fwd/Aft Evaporators)

G. Accomplishment Instructions

1. Prepare helicopter for maintenance

NOTE

Refer to Bell Helicopter Model 429 Maintenance Manual for general removal and installation procedures associated with basic aircraft equipment and components.

- a. Insure all power is removed from the helicopter by disconnecting the battery and removing the external power.
- b. Remove forward cowling assembly to gain access to aft evaporators.
- c. Remove LH & RH chin bubbles to gain access to forward evaporators.
- d. Remove lower nose access panel to gain access to forward evaporator plumbing.
- e. Remove LH & RH nose avionics bay panels to gain access to forward evaporator ducting.
- f. Remove left forward lift frame covers inside cabin to gain access to aft evaporator drain line routing.
- g. Remove cabin headliner to gain access to aft evaporator return air duct installation.
- h. Remove access covers on the LH side step area to gain access to aft evaporator drain check valves.
- i. Evacuate and reclaim refrigerant by discharging air conditioner system in accordance with ICA 429EC-200M-1, Chapter 5.

2. LH Forward Evaporator Installation

- a. Remove and discard the following with attaching hardware in preparation for installation of the LH forward evaporator. (Figures 5 & 6)
 - 1) 429EC-6012-2 Duct Assembly, RH Dual Elbow
 - 2) 429EC-6012-3 Duct Assembly, Flexible
 - 3) 429EC-5040-5 Hose Assembly
 - 4) 429EC-5040-6 Hose Assembly
- b. Install LH forward evaporator as follows (Figure 8):
 - 1) Locate LH forward evaporator assembly Fwd and Aft by matching location of air outlet on evaporators with existing holes in deck.
 - 2) Position evaporator so there is a .20 gap between bottom of deck and top of the evaporator.
 - 3) Position evaporator to achieve .03 gap between S-6031EC-11 (Item 12) LH support bracket and lower surface of deck as shown in Detail H. Match-drill 13/64" (Ø .203) to hole in deck. Secure with attaching hardware as shown.
 - 4) Match-drill S-6032EC-25 (Item 14) and S-6032EC-27 (Item 16) mount brackets 13/64" (Ø .203) to existing inserts in airframe. Secure with attaching hardware.
 - 5) Match-drill S-6031EC-11 (Item 12) LH support bracket to evaporator assembly and secure with attaching hardware.

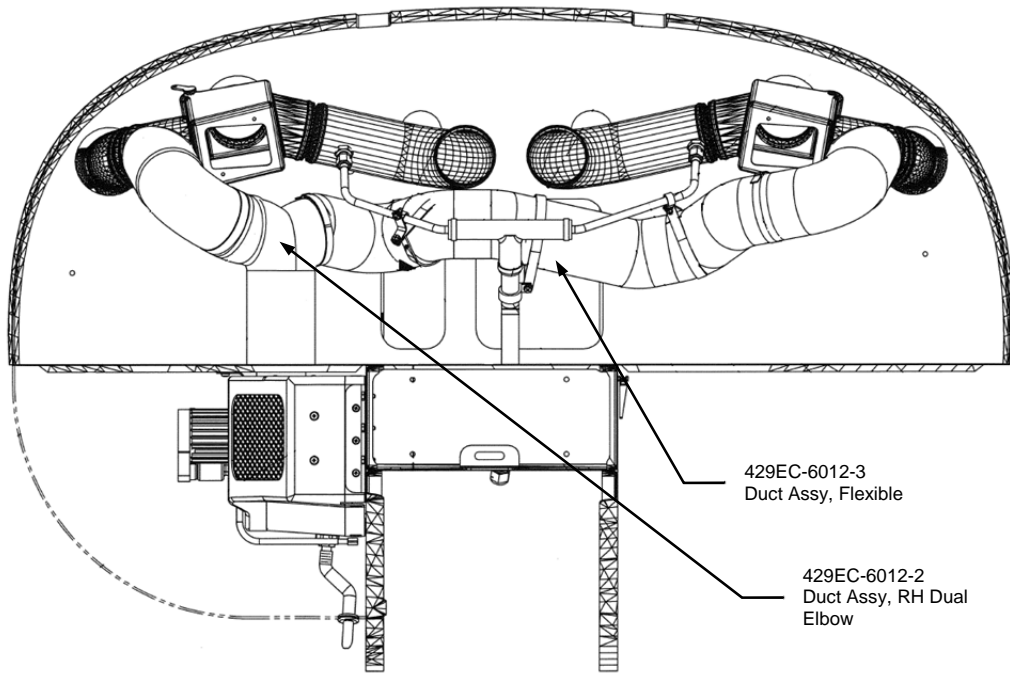

Figure 5: Single Fwd Evaporator Ducting – Nose, View Looking Aft

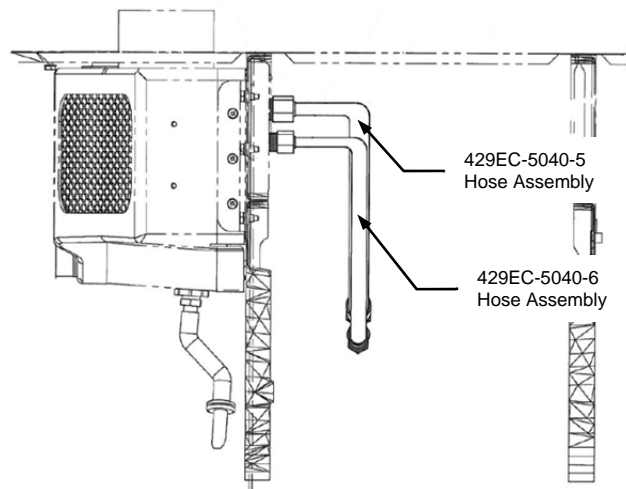

Figure 6: Single Fwd Evaporator Plumbing – Nose, View Looking Aft

- 6) Install S-6066EC-6 (Item 18) and 429EC-6290-1 (Item 9) drain tubes on to evaporator drain fitting. Trim -6 drain tube as needed to fit between -1 drain tube and drain fitting.
- c. Install LH evaporator ducting as follows (Figure 7):
 - 1) Loosely attach 429EC-6010-10 (Item 1) to LH evaporator air outlet. Attach 429EC-6010-10 to 429EC-6010-7 (Item 7). Attach 429EC-6010-7 to 429EC-6010-19 (Item 4) and 429EC-6010-19 to 429EC-6010-5 (Item 6).
 - 2) Locate -5 firmly onto existing ducting. Mark outside flange of -5 to existing ducting.
 - 3) Remove all ducting.
 - 4) Relocate -5 onto existing ducting (where previously marked). Match-drill into existing ducting using #40 (\varnothing .098) drill, Cleco together. Mark existing ducting from inside of -5. Remove -5 from existing ducting and cut existing ducting from inside mark.
 - 5) Attach -5 to existing ducting using GE RTV100 (Black) or equivalent, AD42ABS rivet and NAS1149FN416P washers as shown in Figure 8, Section T-T.
 - 6) Relocate and attach -7, -10, and -19. Seal -10 with GE RTV100 (Black) or equivalent to LH evaporator air outlet.
- d. Install RH evaporator ducting as follows (Figure 7):
 - 1) Attach 429EC-6010-11 (Item 2) to RH evaporator air outlet. Attach 429EC-6010-11 to 429EC-6010-8 (Item 8).
 - 2) Seal -11 with GE RTV100 (Black) or equivalent to RH evaporator air outlet.
- e. Install LH & RH evaporator plumbing as follows (Figure 9):

NOTE

It is acceptable to vary clamping arrangements as required to accommodate aircraft configuration.

- 1) Install 429EC-5020-T5 (Item 5) and 429EC-5020-T7 (Item 6) tube assemblies on RH forward evaporator.
- 2) Install 429EC-5030-H5 (Item 24) and 429EC-5030-H6 (Item 25) hose assemblies on LH forward evaporator.
- 3) Install ES40634-6 (Item 35) and ES40634-8 (Item 36) T-fittings on the appropriate lines.
- 4) Install 429EC-5040-1 (Item 62) and 429EC-5040-2 (Item 61) hose assemblies between T-fittings and anti-plow bulkhead fittings.
- 5) Assembly of fittings:
 - i. Form ends of tubes, if required, to align fittings free of stress.
 - ii. Apply light film of refrigerant oil to O-Ring and install on fitting (O-Ring must be clean).
 - iii. Apply Loctite (Thread Sealer 554 or equivalent) in a small amount to the fittings threads prior to assembly. Insure that O-Ring remains in place during assembly.
 - iv. Torque fittings as follows:
TORQ- LOK Fittings (Face O-Ring): Must be snug (Metal to Metal) and then an additional 30 degrees (one-half flat).
Insert O-Ring Fittings: To be snug against O-ring and then an additional 60 degrees (one flat).

CAUTION

Do not damage O-Ring. Excessive torque will damage fitting.

FLAG NOTE 16 (Figure 9)

FWD evaporators are designed to allow for movement inboard and outboard for fit of tubes, hoses, and tee connections, LH and RH side. To move bulkhead unions, loosen nut and adjust as required for fit. Ensure witness lines located on evaporators DO NOT Rotate more than .06 inches in either direction. When tube, hoses, and tees are installed, tighten the nut against the grommets and seal with RTV.

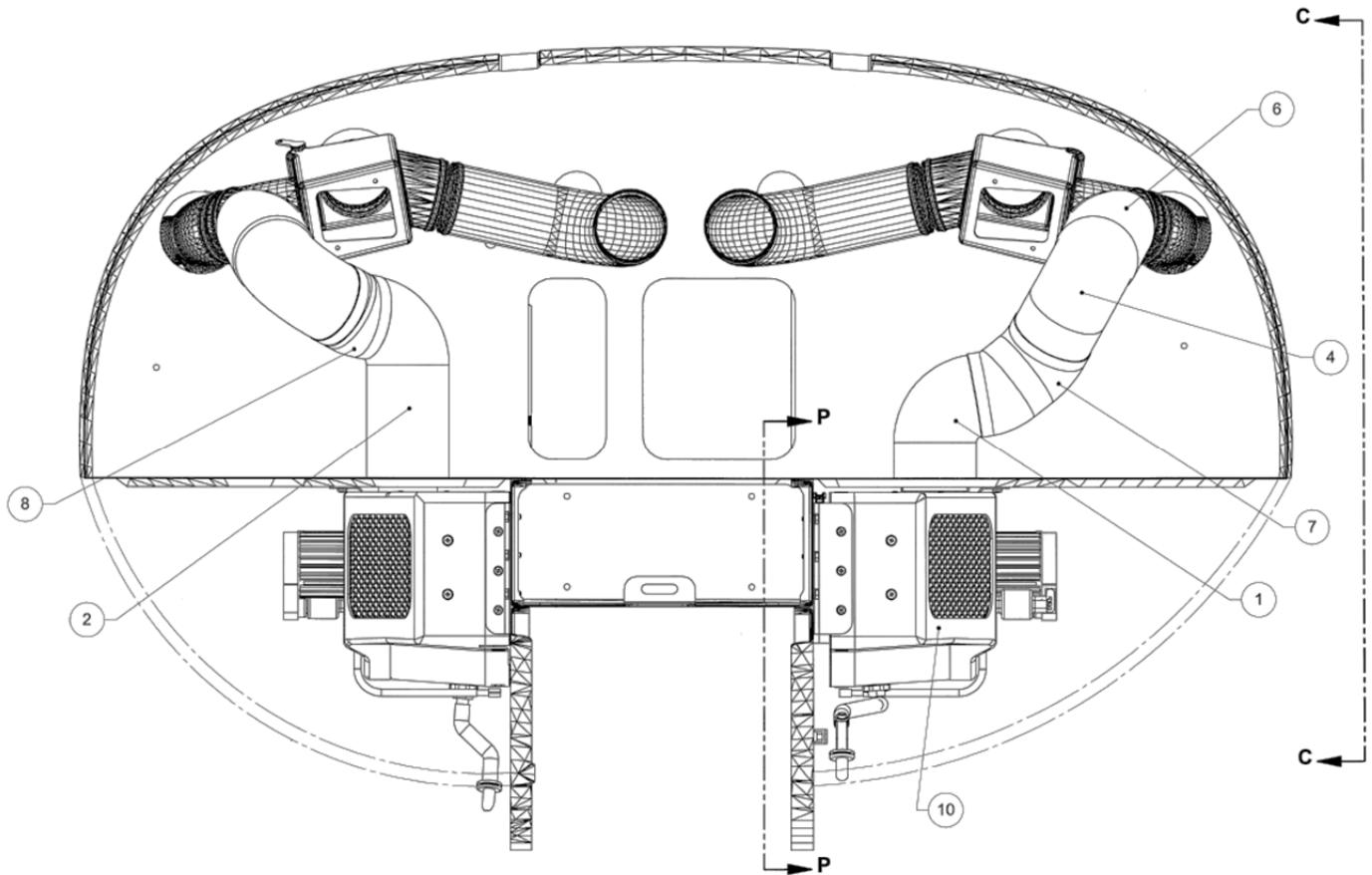

Figure 7: Dual Fwd Evaporator Ducting – Nose, View Looking Aft

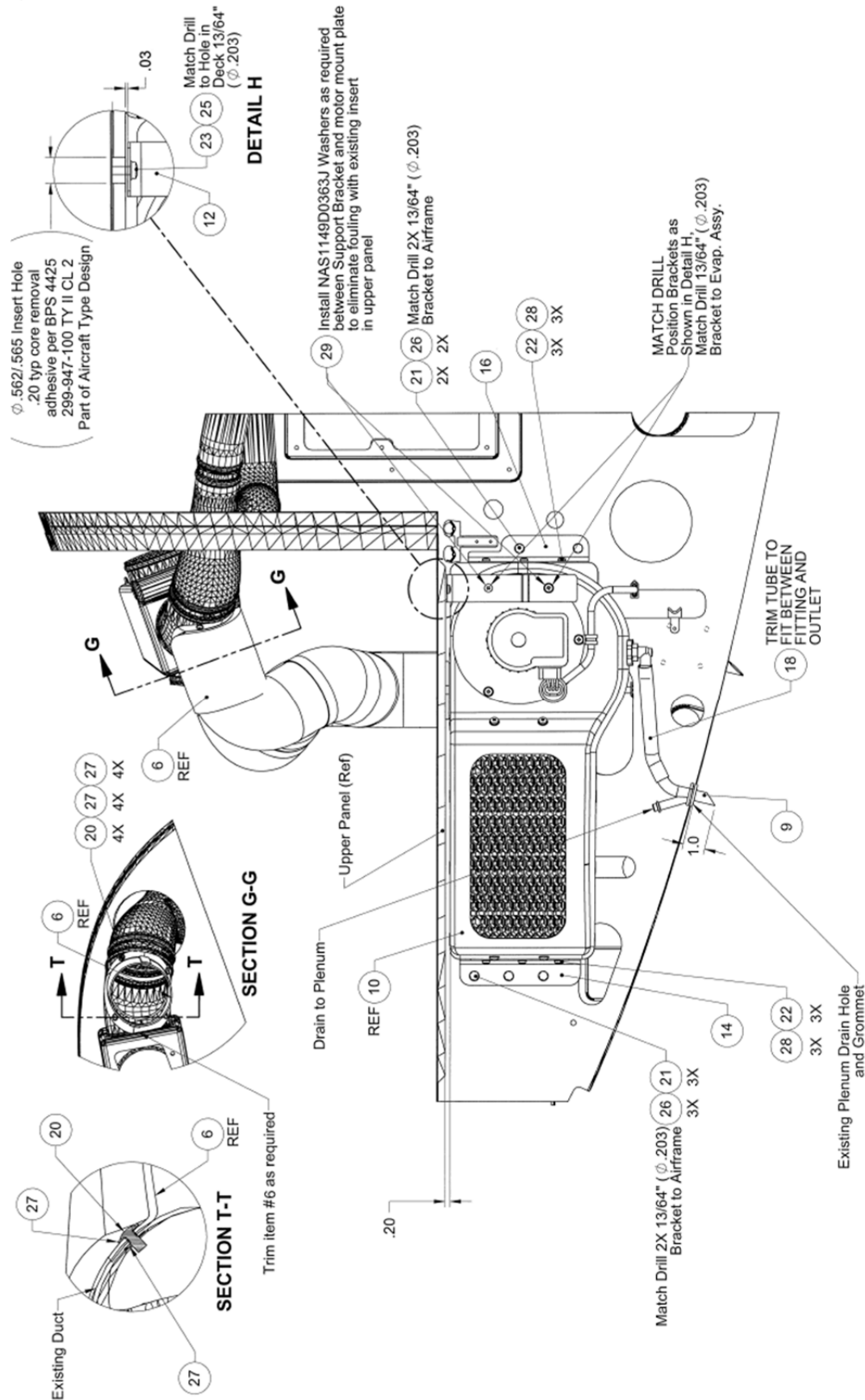

Figure 8: LH Fwd Evaporator – Section C-C Looking Inboard

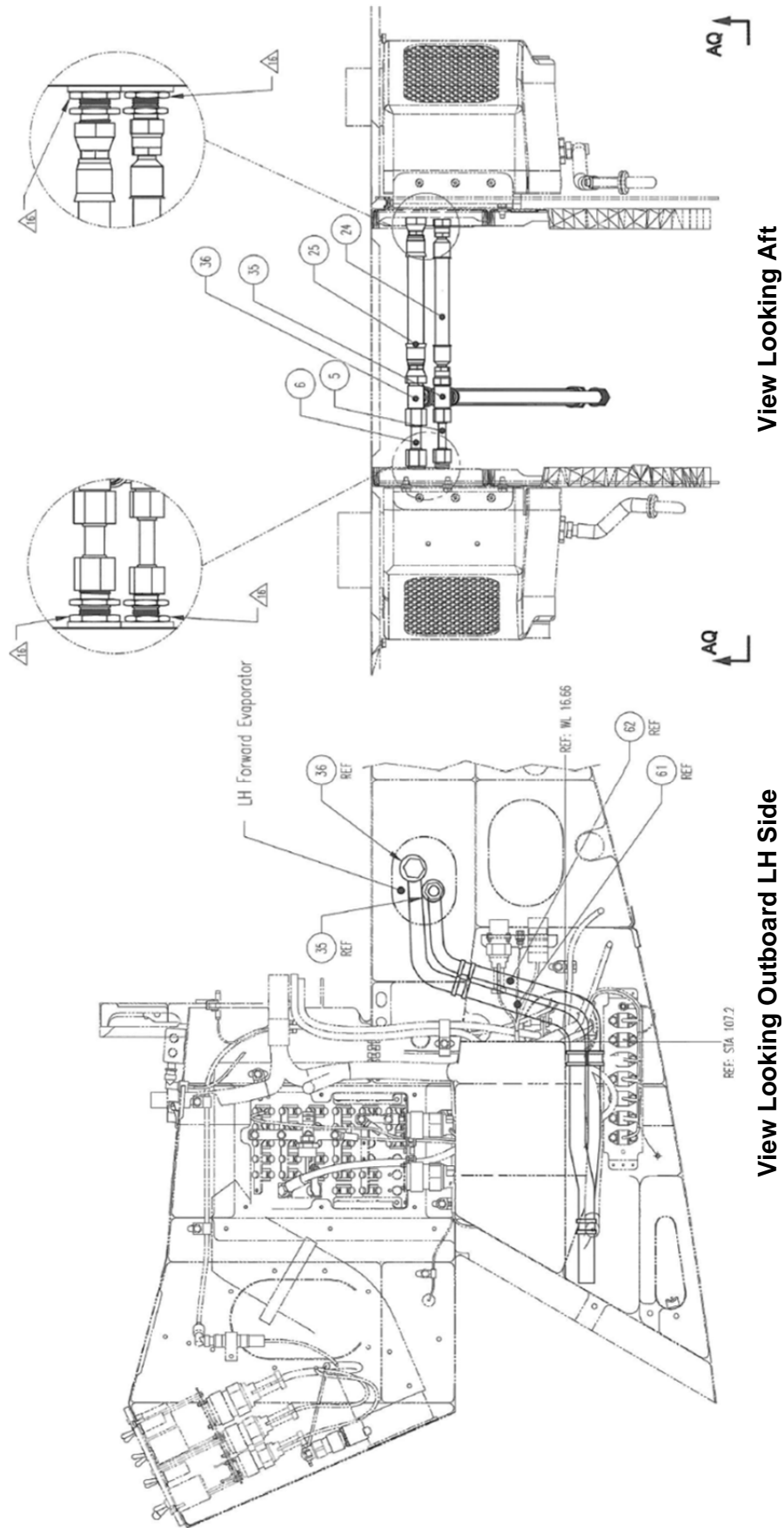

Figure 9: LH & RH Forward Evaporator Plumbing Installation

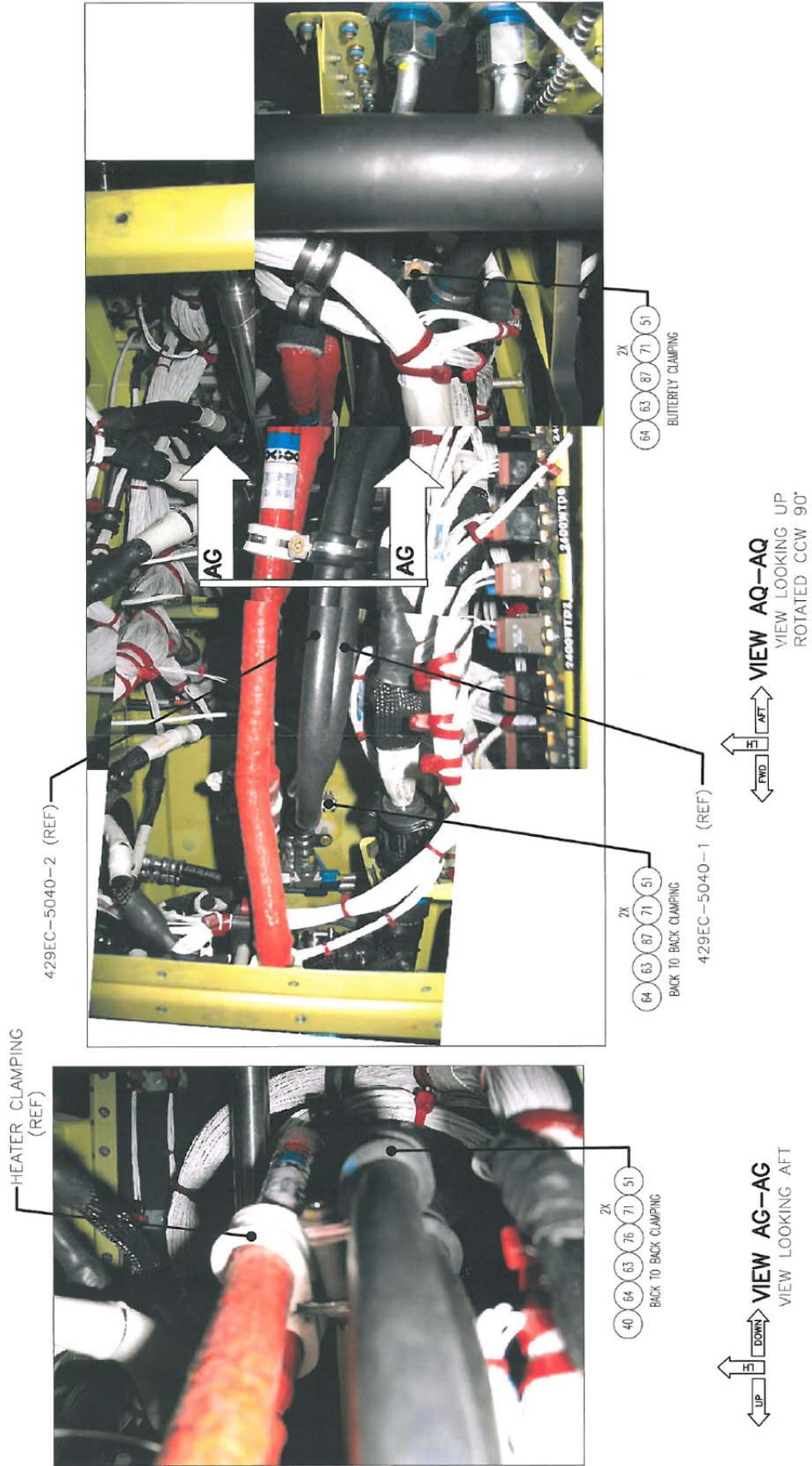
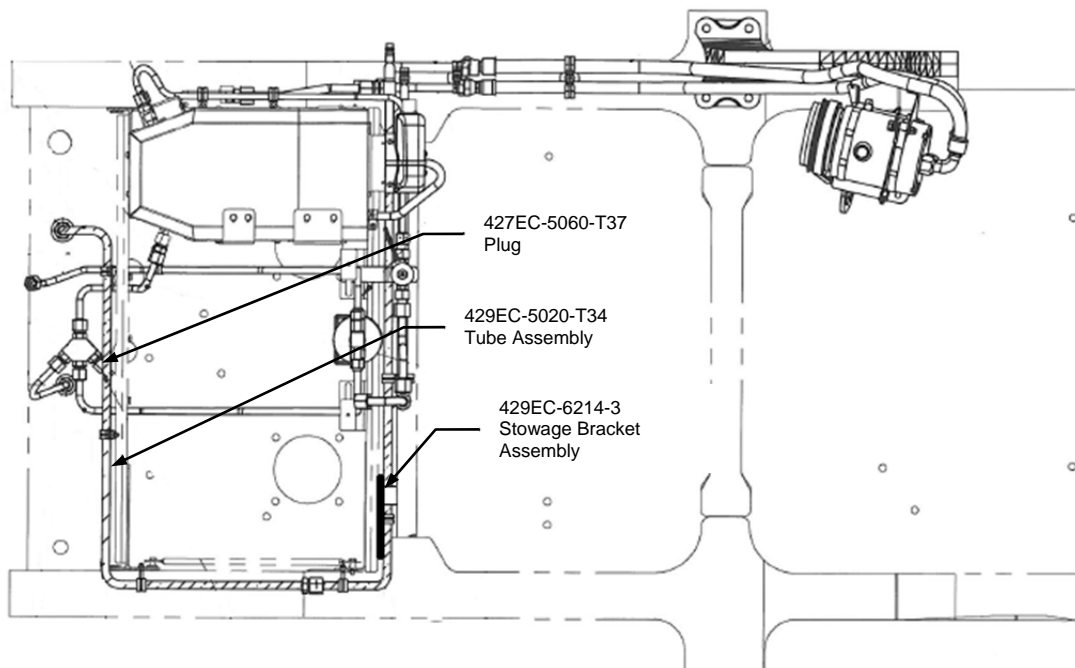

Figure 10: LH & RH Forward Evaporator Clamping Detail

- f. Install LH forward evaporator electrical wiring as follows:
- 1) Un-stow electrical connector for LH forward evaporator and connect to evaporator. Secure wiring as needed.

3. LH Aft Evaporator Installation

- a. Remove and discard the following with attaching hardware in preparation for installation of the LH aft evaporator. (Figure 11)
- 1) 427EC-5060-T37 plug
 - 2) 429EC-5020-T34 tube assembly
 - 3) 429EC-6214-3 stowage bracket assembly



**Figure 11: RH Aft Evaporator – View Looking Down
(Condenser Assembly not shown for clarity)**

- b. Install LH aft evaporator as follows (Figure 12, 13, 14, & 15):
- 1) Prior to installing LH aft evaporator assembly, fasten 429EC-6820-2 (Item 9) upper outlet duct assembly to outlet of aft evaporator with attaching hardware. (Figure 12)
 - 2) Fit 429EC-6820-1 (Item 8) lower outlet duct assembly onto 429EC-6820-2 upper outlet duct assembly. Hold in place with masking tape or other temporary method.
 - 3) Locate LH aft evaporator with aft evaporator outlet duct 429EC-6820-2. Install as shown. (Figure 12)
 - 4) Confirm clearance between Cowling, Flight Controls and Actuators.
 - 5) Position evaporator laterally so that 429EC-7520-12 (Item 5) & -14 (Item 7) mounting brackets are flush against the sides of the condenser. (Figure 13)
 - 6) Remove fasteners in condenser at "a" and "b" (both sides). Install mounting brackets 429EC-7520-12 and -14. Pilot drill upper hole in mounting brackets using existing fastener locations in condenser. Open Pilot holes in upper mounting brackets to \varnothing .203/.208. Install mounting bracket to condenser & evaporator as shown. (Figure 13)

- 7) Match-drill 429EC-6260-10 fwd & 429EC-6260-20 aft channels to aft evaporator. Do not remove both forward and aft fasteners on evaporator at the same time. (Figures 14 & 15)
- 8) Seal electrical bond by applying a bead of sealing on bonded area using sealant MIL-PRF-81733. Bonded area should be sealed within 7 days. Seal all around aft evaporator and -10/-20 channels using Pro-Seal 890 or equivalent to achieve seal of bonded (grounded) area. (Figure 14, Flag Note 9)

NOTE

It is permissible to slot (3) holes on (429EC-6260-10 channel) and (2) holes on (429EC-6260-20 channel) for aft evaporator attachment. Slot to be .40 max.

- 9) Rotate 429EC-6820-1 lower outlet duct assembly to be concentric with \varnothing 4.40 hole in airframe, aft. Match-drill 429EC-6820-1 lower outlet duct assembly flange with holes in airframe (4X each). (Figure 12)
 - 10) Fasten 429EC-6820-1 lower outlet duct assembly to airframe, aft with indicated hardware and existing inserts. (Figure 12)
 - 11) Seal completely around joint using GE RTV103 Black Silicone Rubber Adhesive Sealant (4 Plcs). (Figure 12, Flag Note 6)
- c. Install LH aft evaporator plumbing as follows (Figure 16, 17, & 18):
- 1) Install 429EC-5020-T12 (Item 10) tube assembly and ES40632-6D (Item 33) union between aft evaporator and existing EC135-5010-1 (Item 28) manifold assembly. (Figure 16)
 - 2) Install 429EC-5020-T9 (Item 7) tube assembly and S-5080EC-10 (Item 41) Y-fitting assembly between aft evaporator and existing ES40630-8L (Item 32) bulkhead fitting. (Figure 17 & 18)
 - 3) Assembly of fittings:
 - i. Form ends of tubes, if required, to align fittings free of stress.
 - ii. Apply light film of refrigerant oil to O-Ring and install on fitting (O-Ring must be clean).
 - iii. Apply Loctite (Thread Sealer 554 or equivalent) in a small amount to the fittings threads prior to assembly. Insure that O-Ring remains in place during assembly.
 - iv. Torque fittings as follows:
TORQ- LOK Fittings (Face O-Ring): Must be snug (Metal to Metal) and then an additional 30 degrees (one-half flat).
Insert O-Ring Fittings: To be snug against O-ring and then an additional 60 degrees (one flat).

CAUTION

Do not damage O-Ring. Excessive torque will damage fitting.

- 4) Install clamps (Item 102) and attaching hardware securing new tube assemblies. (Figure 17 & 18)

FLAG NOTE 15 (Figure 17 & 18)

When new tube assemblies are connected, slide insulation sleeve over union and B-nuts as shown.

- d. Install LH aft evaporator return air ducting as follows (Figure 19, 20, 21, & 22):
- 1) Remove the existing 429EC-6210-101 Plenum Cover over the left headliner air outlet opening and the 429-030-096-101 cover from the air inlet opening over the copilot's seat.
 - 2) Fasten 429EC-6814-1 (Item 6) baffle duct assembly and 429EC-6810-3 (Item 3) duct adapter to Air Plenum Manifold, using indicated hardware and existing nutplates. (Figure 20)
 - 3) Dry fit 429EC-6810-1 (Item 1) upper return duct assembly, 429EC-6811-1 (Item 5) one way duct assembly and 429EC-6810-2 (Item 2) lower return duct assembly, hold together with masking tape or other temporary method. Orient 429EC-6811-1 one way duct assembly so the inside valve assembly is furthest away from LH aft evaporator. (Figure 21, Flag Note 9)
 - 4) Ty-wrap NAS520-34-10 (Item 18) coupling onto 429EC-6810-15 adapter duct - middle of 429EC-6811-1 one way duct assembly. These 2 sets of parts will be referred to as fitted assembly later on. (Figure 21, Flag Note 9)
 - 5) Clamp 429EC-6810-1 upper return duct assembly of fitted assembly to aft evaporator so Ø 4" holes are centered. Align side adapter of 429EC-6811-1 one way duct assembly to 429EC-6810-3 duct adapter and attach with Masking Tape or other temporary method. Align 429EC-6810-2 lower return duct assembly using dimensions as shown (adjust clamping of 429EC-6811-1 one way duct assembly as required). (Figure 21, Flag Note 10)
 - 6) Match-drill holes of aft evaporator assembly inlet into 429EC-6810-1 upper return duct assembly. (Figure 22)
 - 7) Mark for trimming 429EC-6810-1 upper return duct assembly flange at side edges, lid, and support bracket of aft evaporator assembly. (Figure 22, Flag Note 14)

NOTE

For top flange of 429EC-6810-1, insert under lid of aft evaporator assembly, trim as required and match-drill (2) holes. Re-install fasteners.

- 8) Kleco 429EC-6810-2 lower return duct assembly into place. Mark insulation for trimming on fitted assembly if bunching occurs. Remove fitted assembly. (Figure 21, Flag Note 15)
- 9) Trim insulation and flange of fitted assembly. (Figure 18 & 19, Flag Note 16)
- 10) Immediately fasten fitted assembly into place after the following: Seal completely around joints and adhere insulation of fitted assembly using GE RTV103 Black Silicone Rubber Adhesive Sealant. (Figure 21 & 22, Flag Note 17)
- 11) Seal completely around 429EC-6810-1 upper return duct assembly flange and aft evaporator assembly using GE RTV103 Black Silicone Rubber Adhesive Sealant. (Figure 21 & 22, Flag Note 18)
- 12) Complete installation by ty-wrapping NAS520-34-10 coupling of fitted assembly to the 429EC-6810-3 duct adapter. (Figure 20)
- 13) Seal all around Flange and Hardware using Pro Seal 890-B2. (Figure 12 & 19, Flag Note 20)

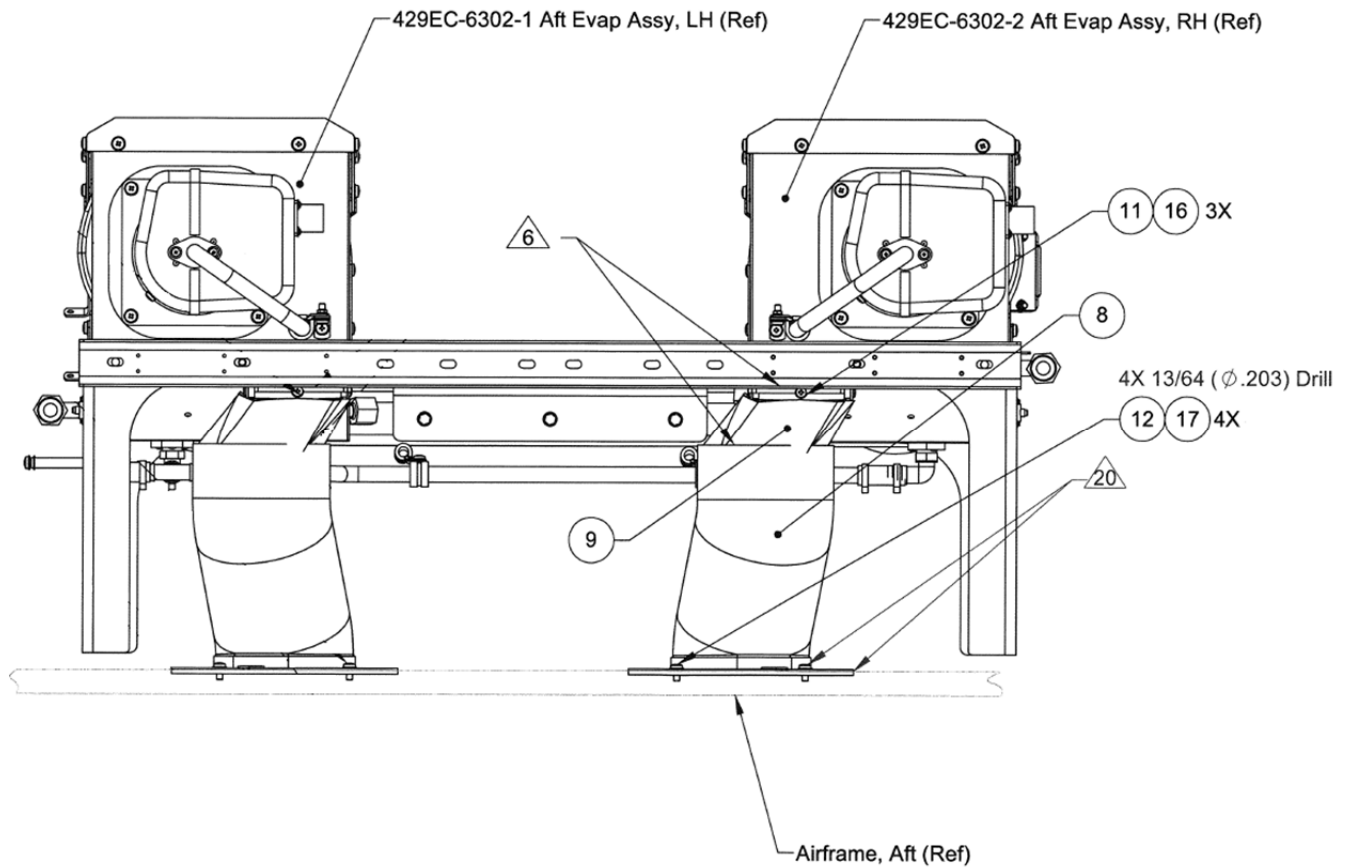

Figure 12: LH Aft Evaporator Outlet Ducting – View Looking Forward

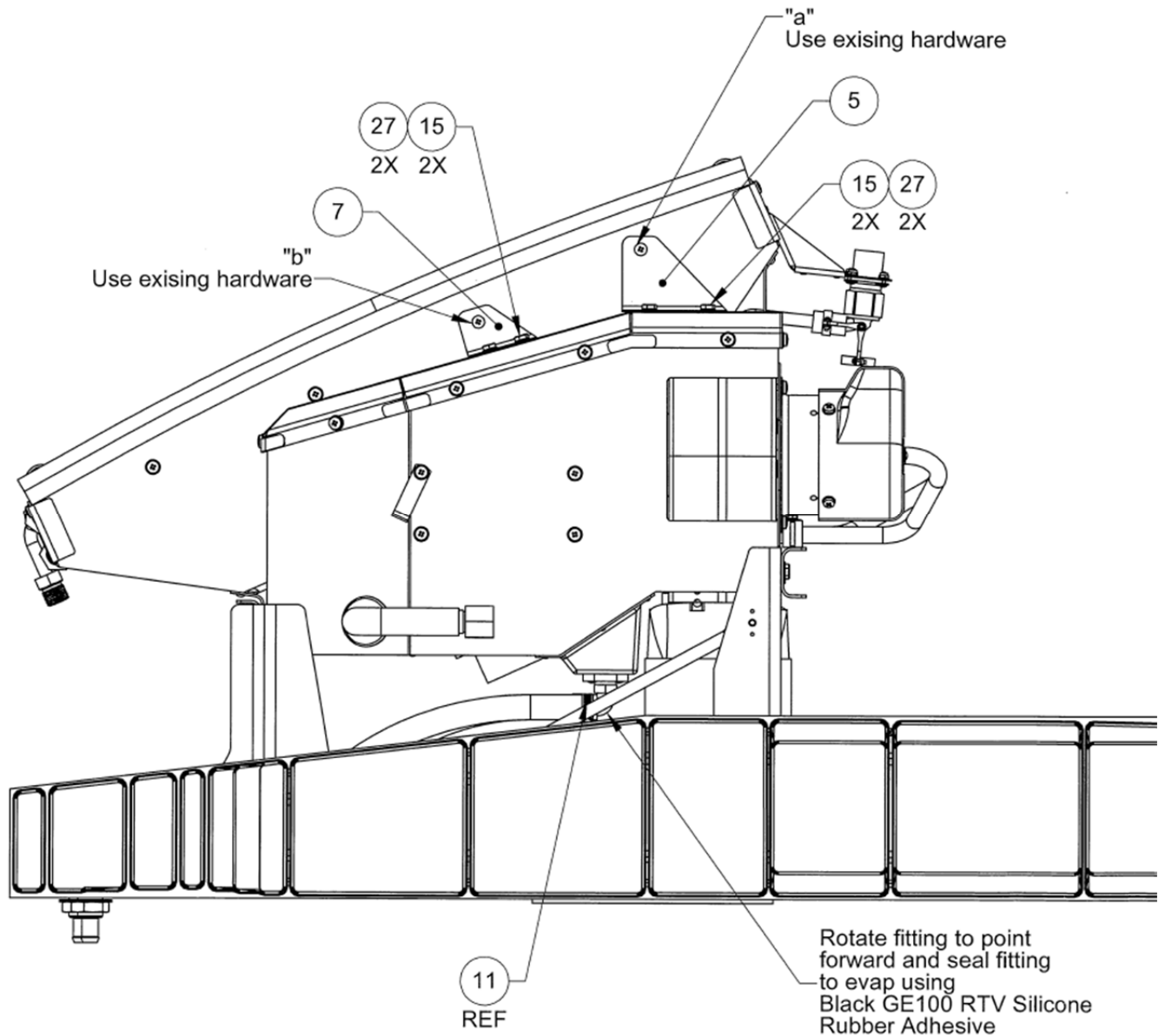

Figure 13: LH Aft Evaporator Installation – View Looking Inboard LH Side

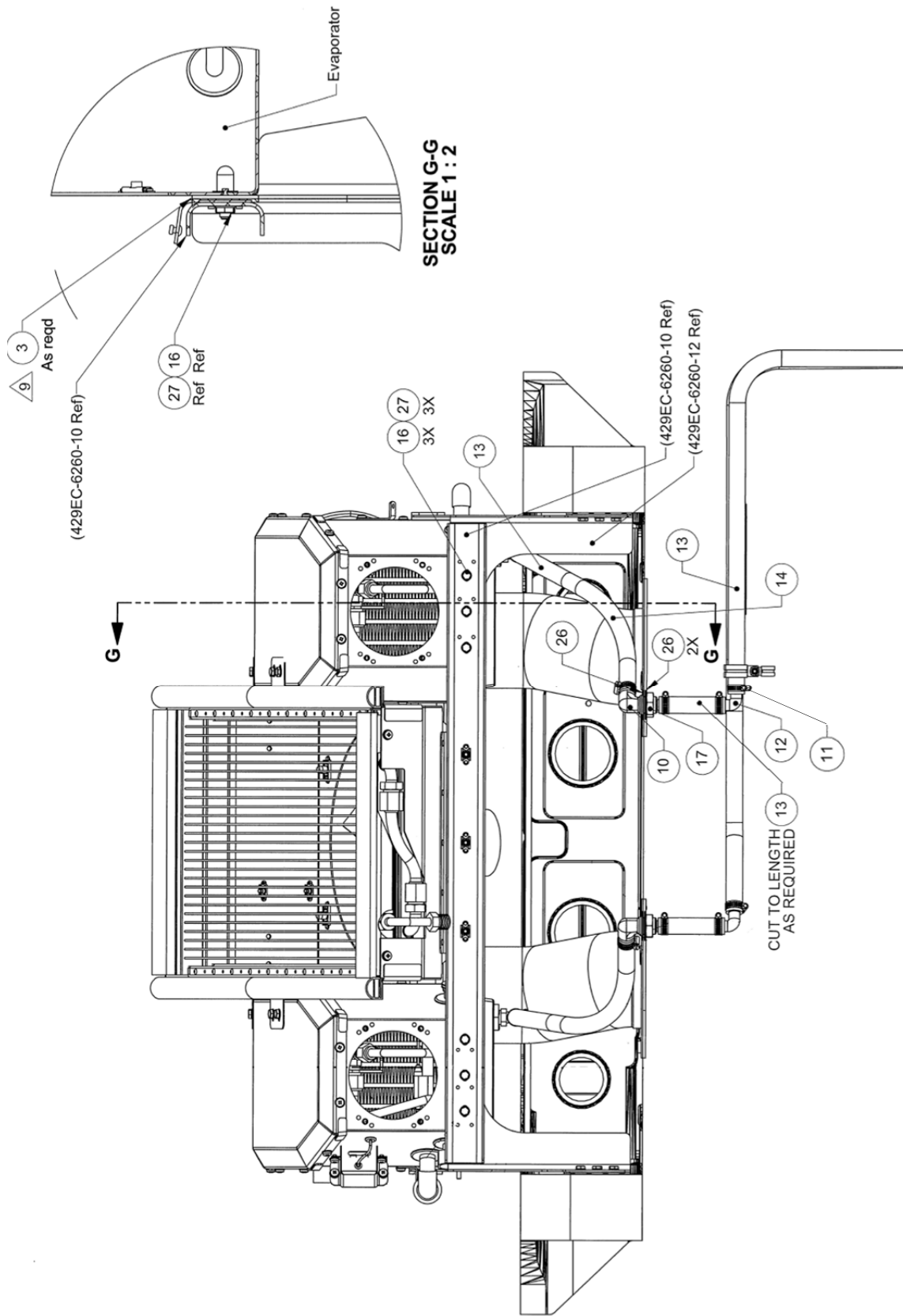

Figure 14: LH Aft Evaporator Installation – View Looking Aft

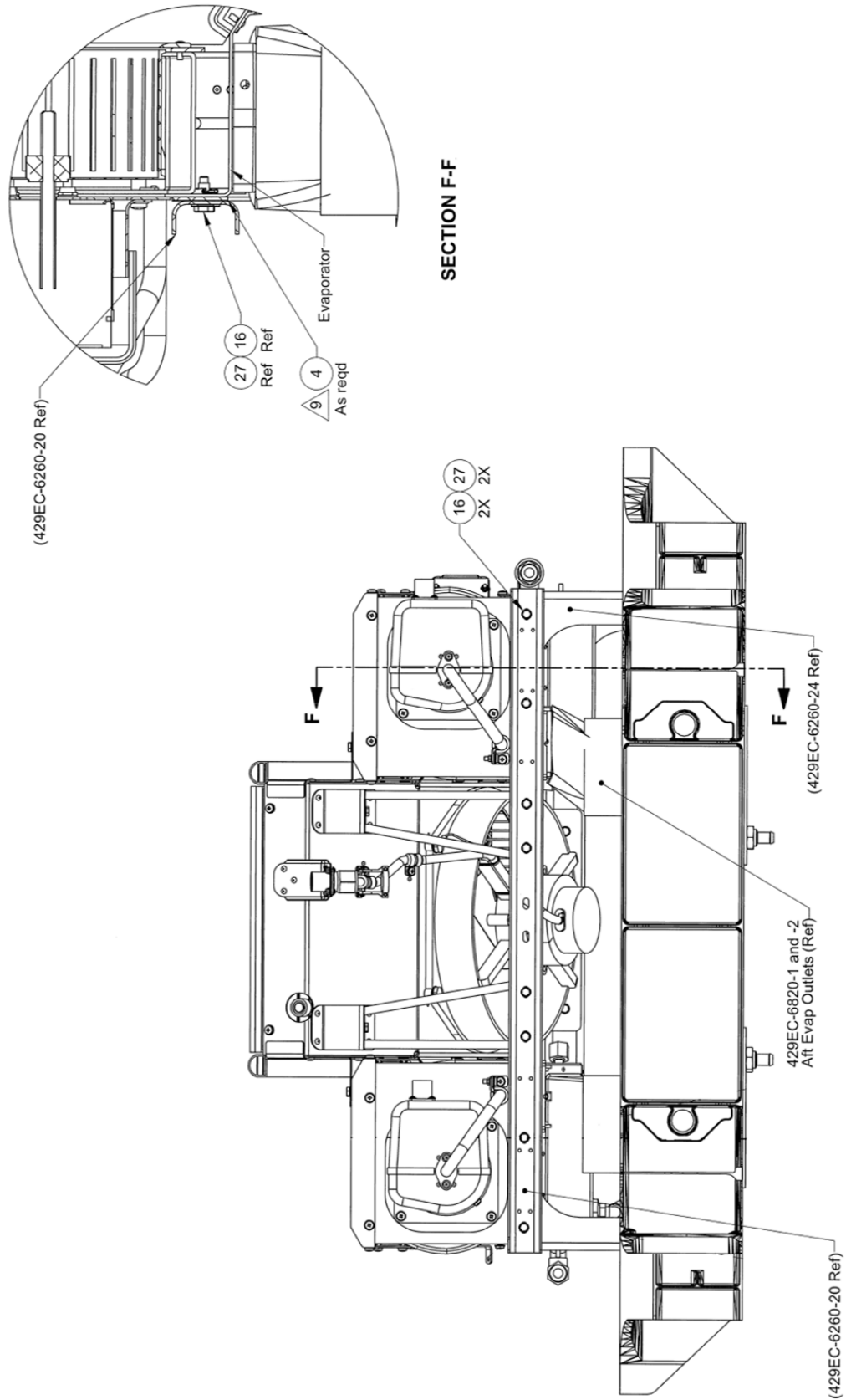

Figure 15: LH Aft Evaporator Installation – View Looking Fwd

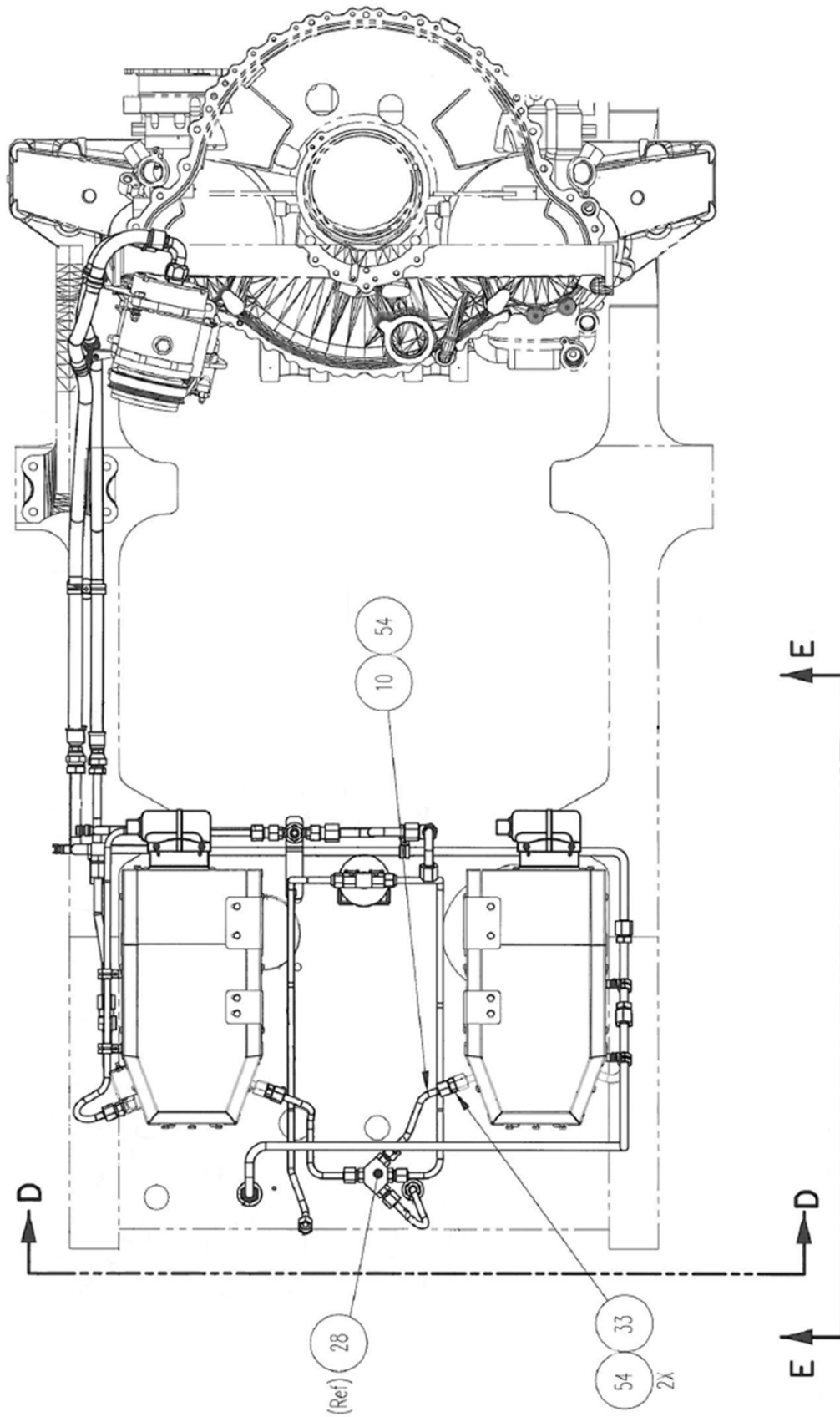
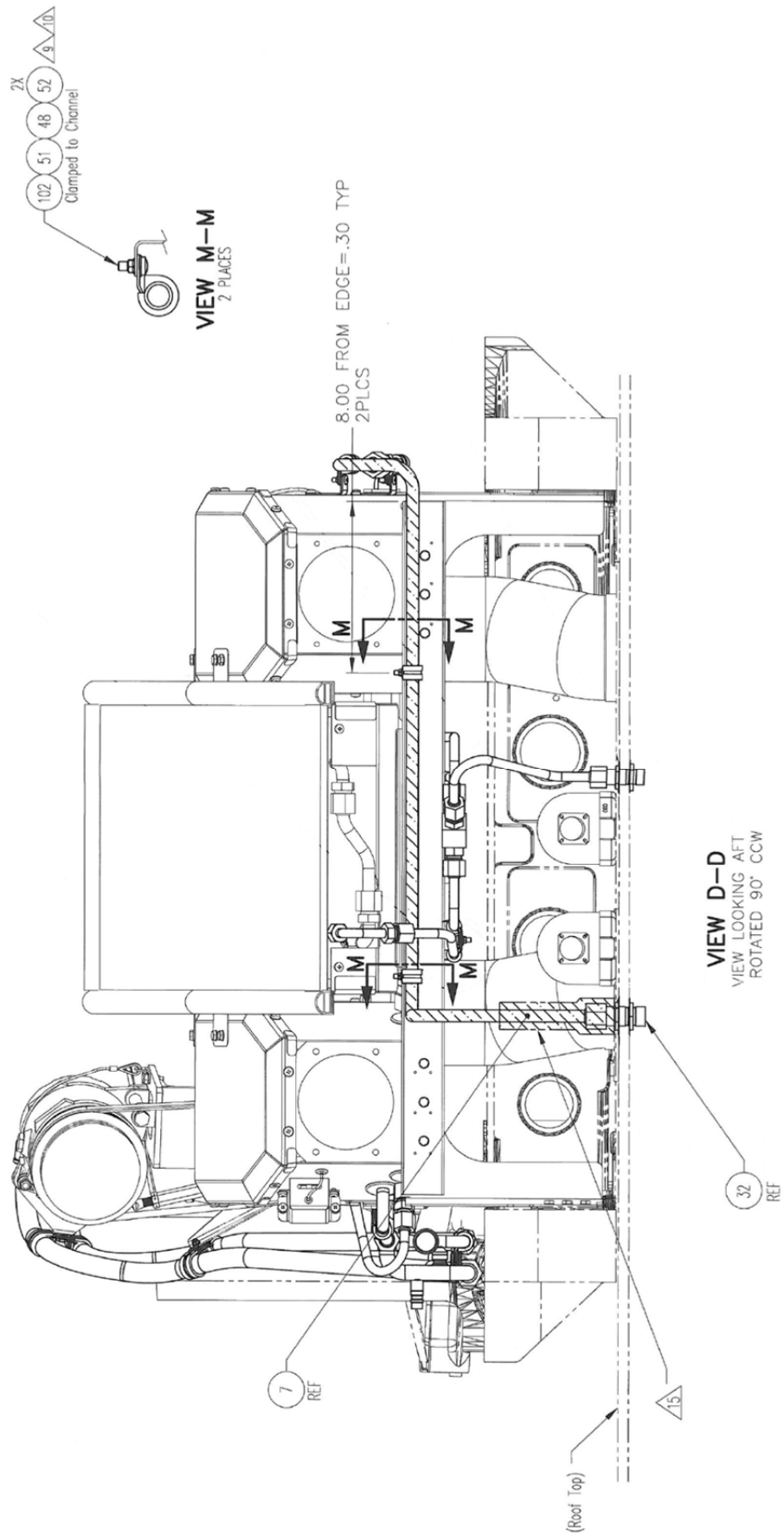

Figure 16: LH Aft Evaporator Plumbing Installation
View Looking Down



**Figure 17: LH Aft Evaporator Plumbing Installation
 View Looking Aft**

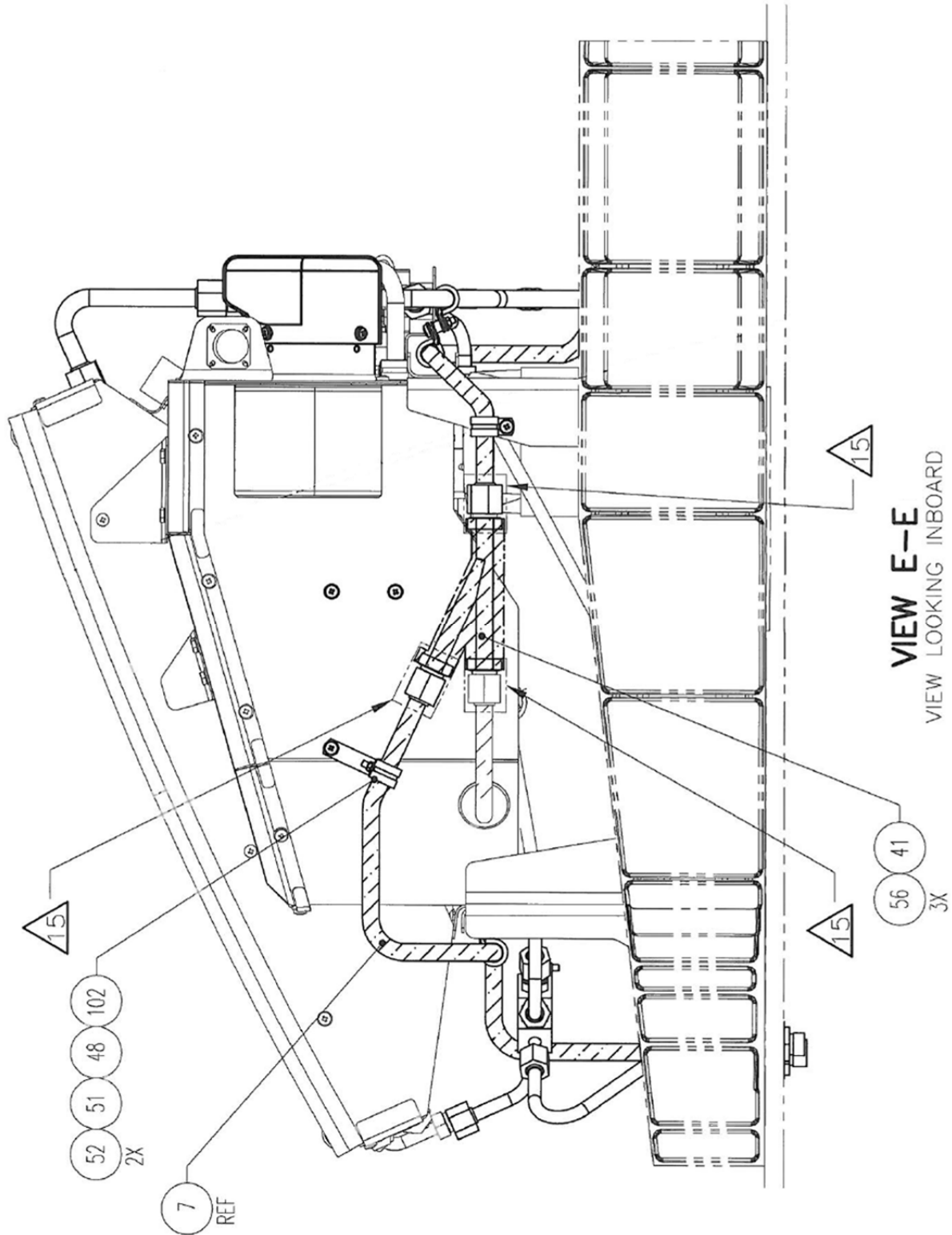
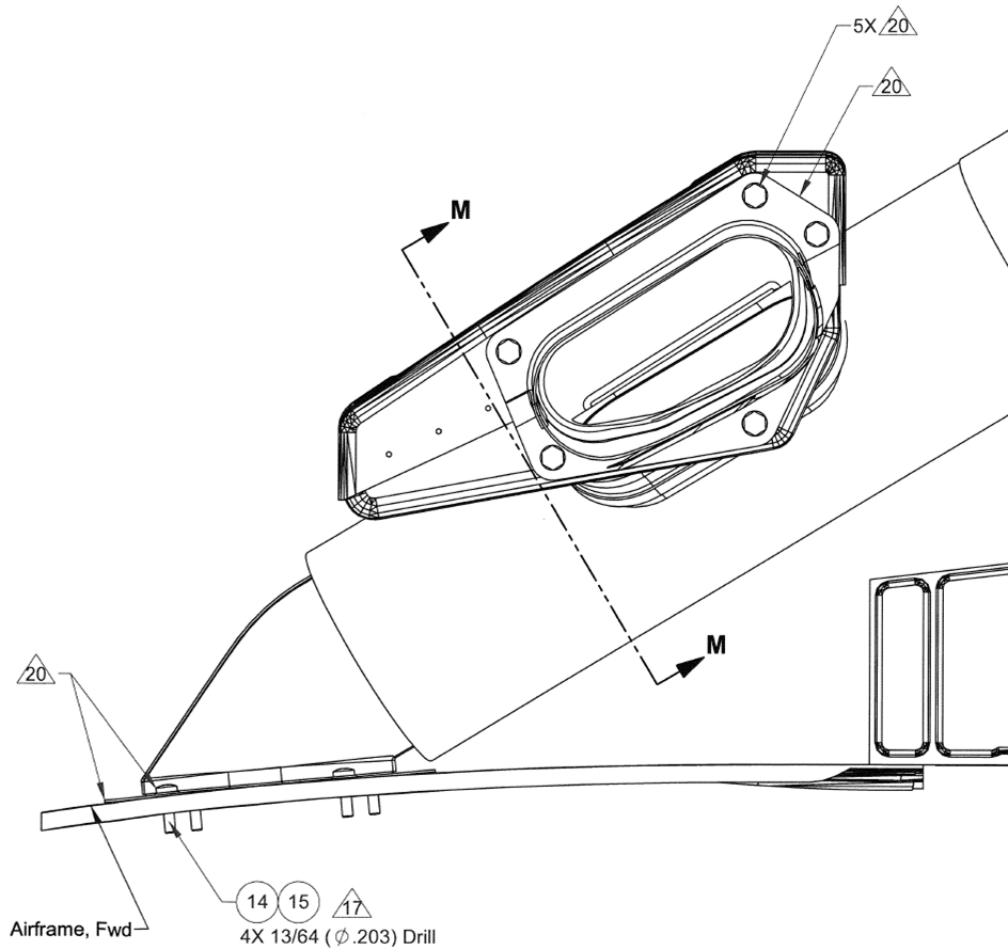
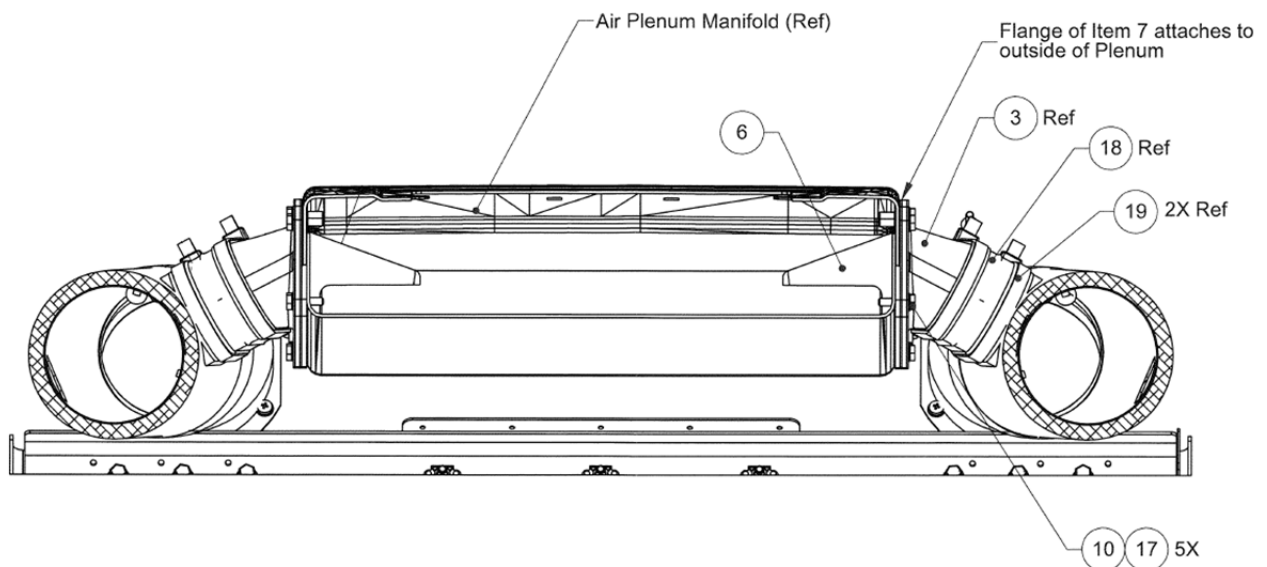

Figure 18: LH Aft Evaporator Plumbing Installation
View Looking Inboard



Section D-D (Figure 21)

Figure 19: Air Plenum Connection – View Looking Outboard LH Side



Section M-M (Figure 19)

Figure 20: LH Aft Evaporator Installation – View Looking Inboard LH Side

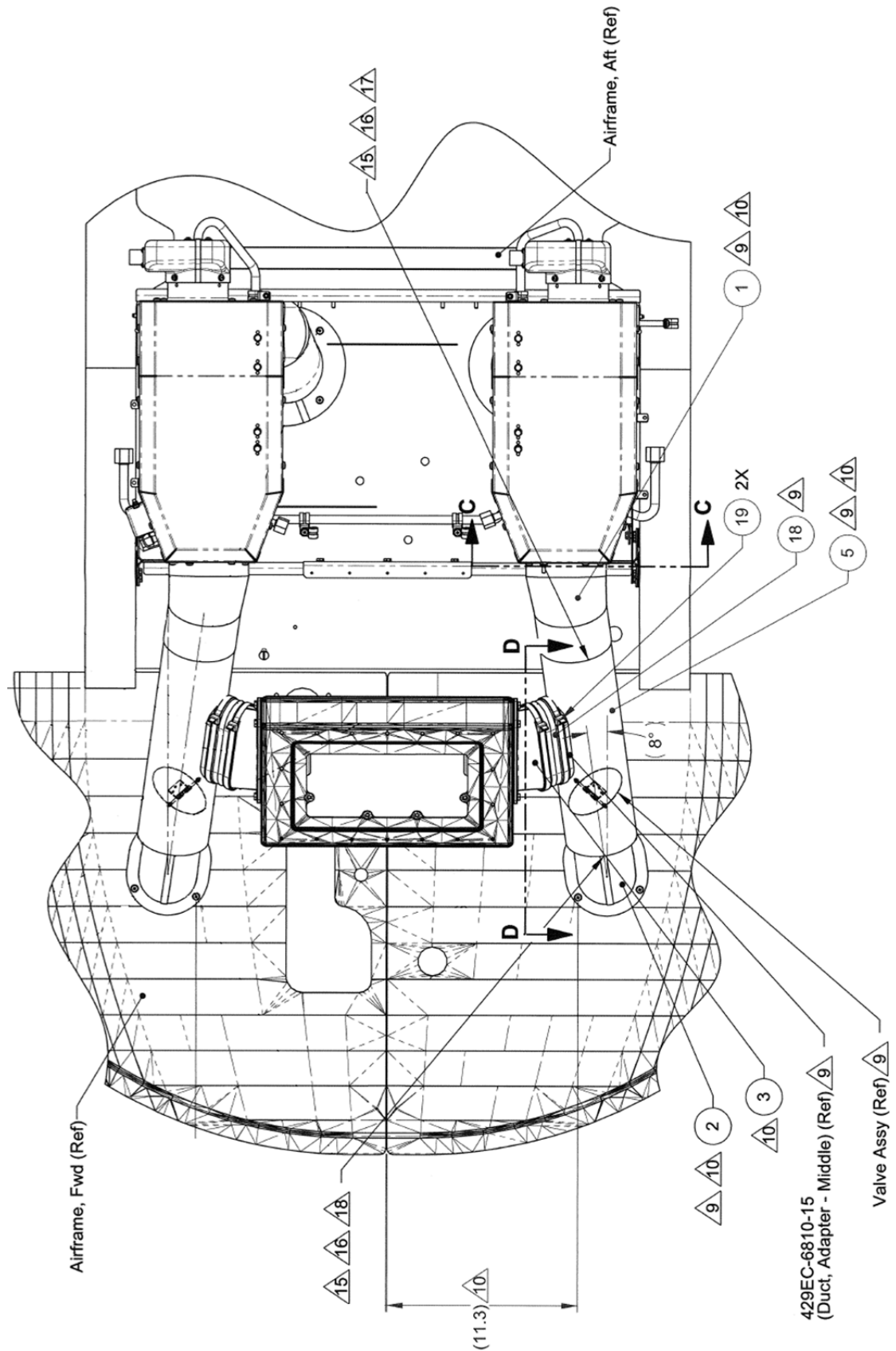
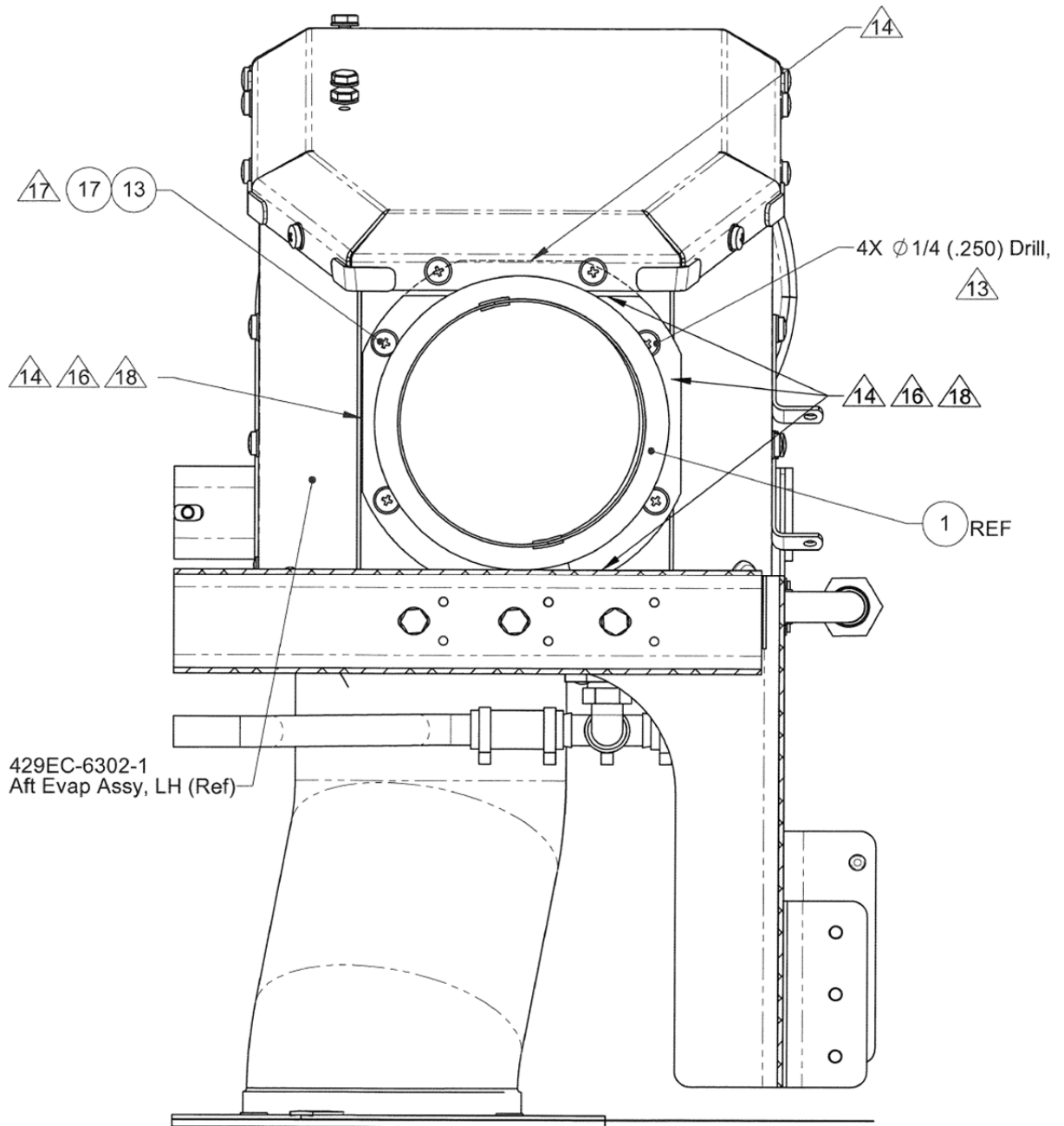

Figure 21: LH Aft Evaporator Installation – View Looking Down



Section C-C (Figure 21)
Figure 22: LH Aft Evaporator Installation – View Looking Aft

- e. Install LH aft evaporator water drain plumbing as follows (Figure 14, 23, & 24):
- 1) Ensure that Bell Technical Bulletin 429-11-12 is complied with prior to installing additional drain line for helicopter serial numbers 57001 - 57051. The bulletin provides instructions to locate and drill passage holes allowing installation of additional drain lines.
 - 2) Locate and install S-6554EC-1 (Item 10) bulkhead fitting and attaching hardware. Seal using Mil-PRF-81733 sealant, or equivalent. (Figure 14)
 - 3) Install ES48154-1 (Item 13) drain hose as required from evaporator drain fitting to S-6554EC-1 bulkhead fitting and secure using ES30043-2 (Item 11) hose clamps. (Figure 14)
 - 4) Route ES48154-1 drain hose to underside of bulkhead fitting and secure using ES30043-2 hose clamps. (Figure 14)
 - 5) Route and clamp ES48154-1 drain hose down the left side keel beam to check valve location. (Figure 23 & 24)
 - 6) Locate and install MS35489-149 (Item 24) grommet and P/N S-6552EC-1 (Item 9) check valve in lower left fuselage. (Figure 24)

FLAG NOTE 11 (Figure 24)

Aft Evaporator water drain fitting holes are part of the aircraft type design. On aircraft serial numbers 57001 through 57051, these holes may not be present. If not, perform BHT TB 429-11-12.

- 7) Water Drain Test Procedure: Pour approximately 1 quart of water into the air inlet (front of evaporator) to verify drain is working properly. Collect drainage and verify that most of the 1 quart of water drained through. Some residual water may be left in the line, especially at any low point and depending on the level of the aircraft. This is normal and does not constitute a failure of the drain system. Verify that there are no leaks in the tubing or joints.
- f. Install LH aft evaporator electrical wiring as follows (Figure 25, 26, & 27):
- 1) Attach connector ACP8 to LH aft evaporator blower assembly. Secure wiring with clamps and attaching hardware as shown. (Figure 25)
 - 2) Install LH AFT circuit breaker MS26574-15 in RH non-essential bus circuit breaker panel. Secure wiring as needed. (Figure 26)
 - 3) Remove existing FWD EVAP decal S-8004EC-1 to reveal LH AFT evaporator legend.

4. Test/Final Steps

- a. Ensure security of all air conditioner components.
- b. Service air conditioner system with refrigerant in accordance with ICA 429EC-200M-1, Chapter 5.

WARNING

Evaporator blowers are designed to operate with the resistance of the entire ducting system. Operation of the evaporator blowers with any part of the air distribution system removed may cause permanent damage to the fan motor. Blowers may take up to 10 seconds to start after the switch is turned on. Keep hands away from blower whenever switch is in "Fan" or "A/C" positions.

- c. Ensure ground power unit is attached and providing +28 VDC power to the aircraft. Switch helicopter power on.
- d. Verify operation of evaporator blowers as follows:
 - 1) At the Cockpit's Air Conditioner Control Panel:
 - i. Place the AIR COND switch in the FAN position and verify:
 - 1. That both the fwd and aft blowers are activated and operating - Rotate speed control knobs to verify blowers increase and decrease speed accordingly.
 - 2. That the condenser blower is non-operational.
 - ii. Place the AIR COND switch in the OFF position and verify:
 - 1. That both the fwd and aft blowers deactivate.
- e. Install all removed panels and cowling.
- f. Restore aircraft to flight condition.
- g. Confirm operation of air conditioner system.
- h. Record compliance with this Service Bulletin in aircraft documents.

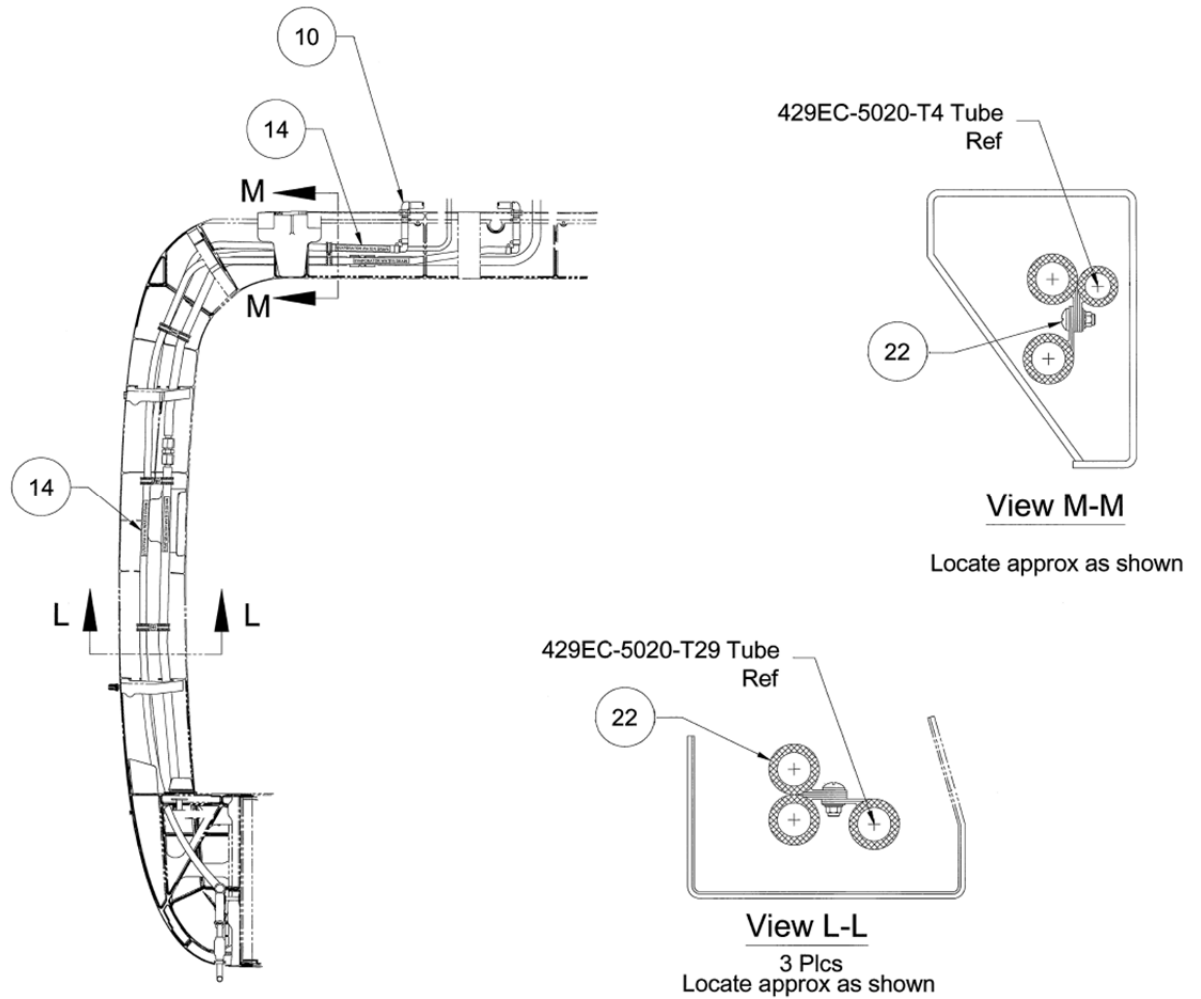

**Figure 23: LH Aft Evaporator Drain Line Installation
View Looking Fwd, LH Side**

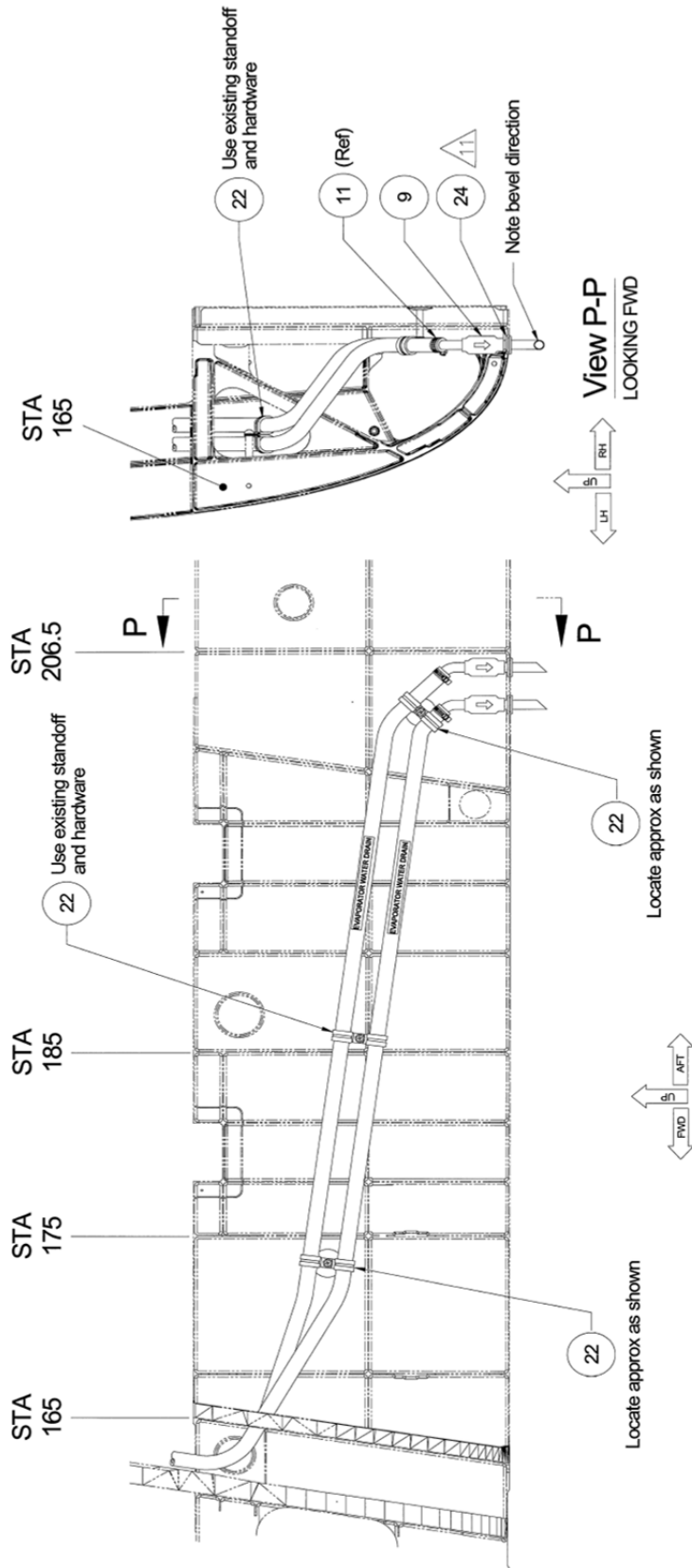

Figure 24: LH Aft Evaporator Drain Line Installation – View Looking Inboard, LH Side

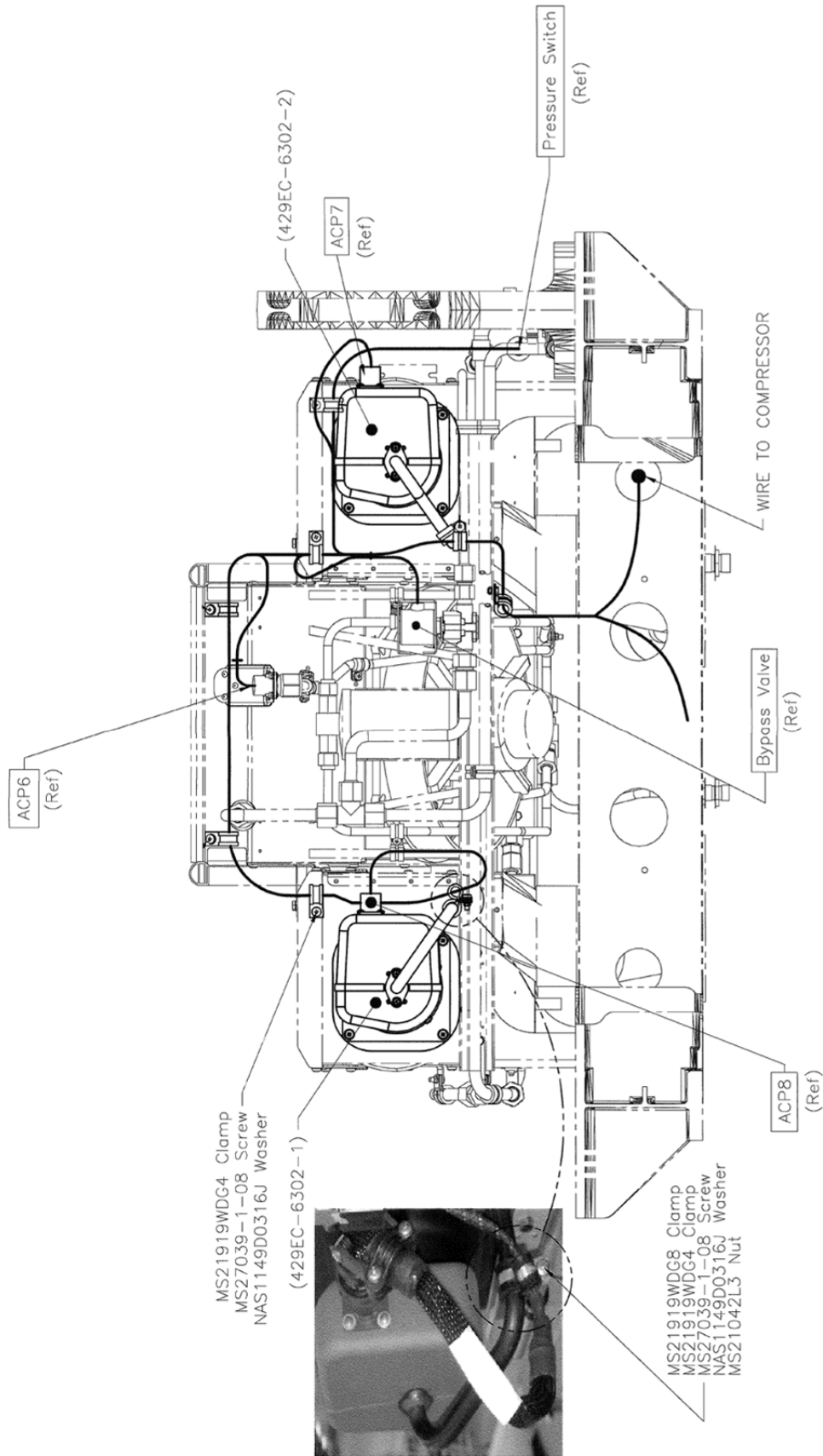
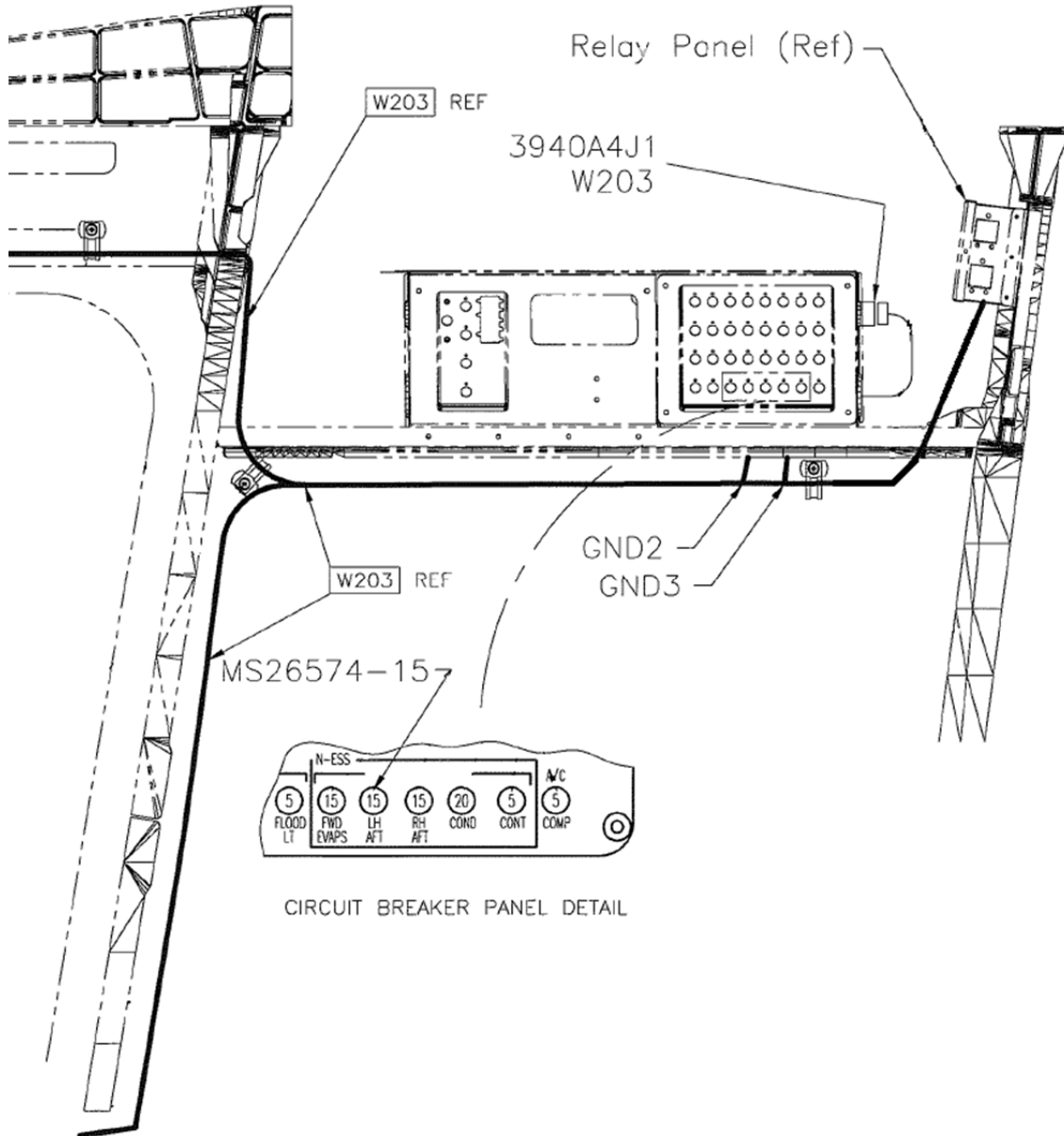

Figure 25: LH Aft Evaporator Electrical Installation – View Looking Forward



**Figure 26: LH Aft Evaporator Circuit Breaker Installation
RH Non-Essential Bus – View Looking Outboard, RH Side**

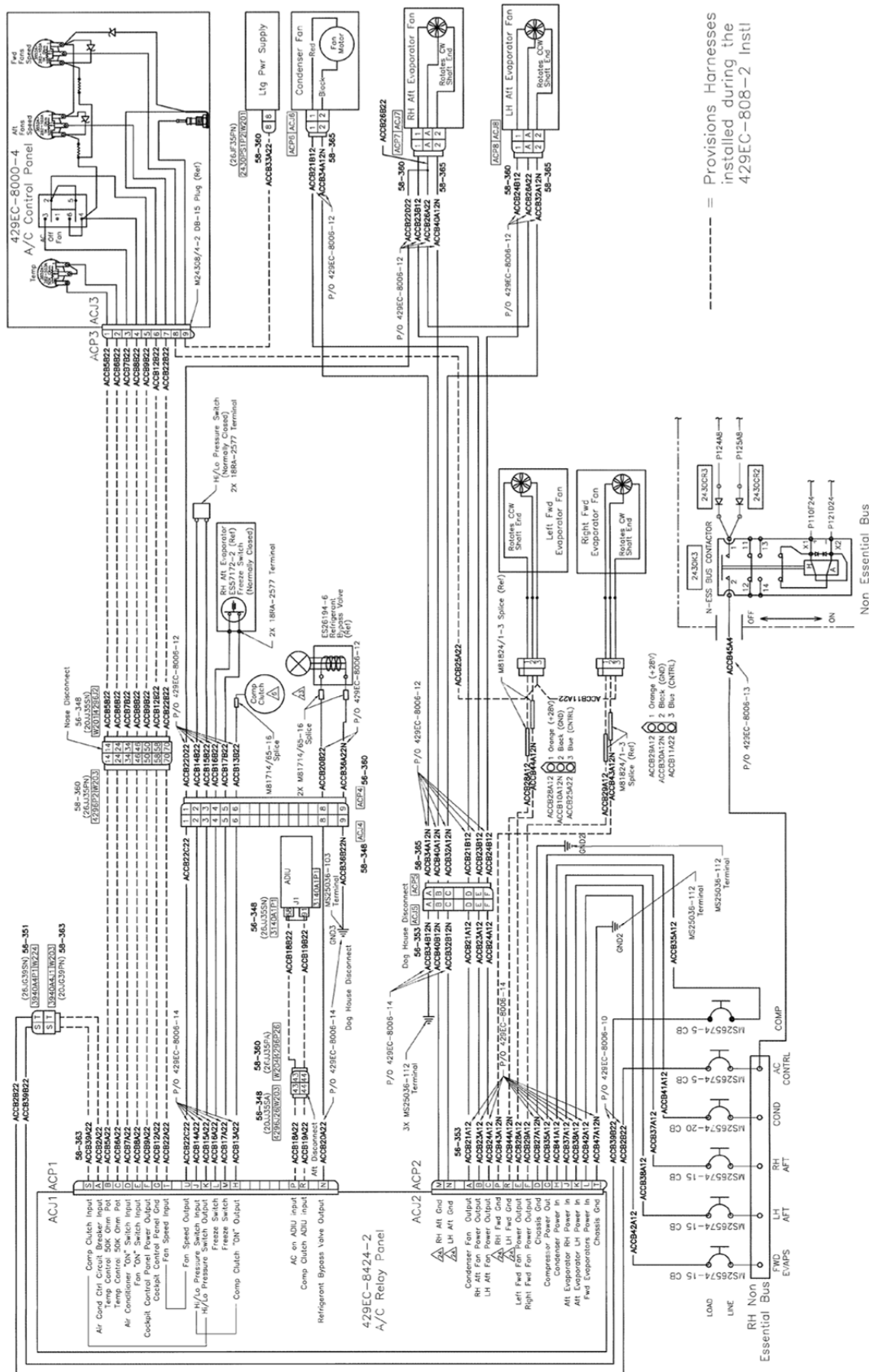

Figure 27: Dual Evaporator Electrical Schematic