

AIR COMM CORPORATION
1575 W. 124th Avenue
WESTMINSTER, CO. 80234
PHONE: 303-440-4075 FAX: 303-440-6355
INFO@AIRCOMMCORP.COM

**INSTRUCTIONS FOR CONTINUED AIRWORTHINESS
BELL HELICOPTER 206L4
AIR CONDITIONING SYSTEM**

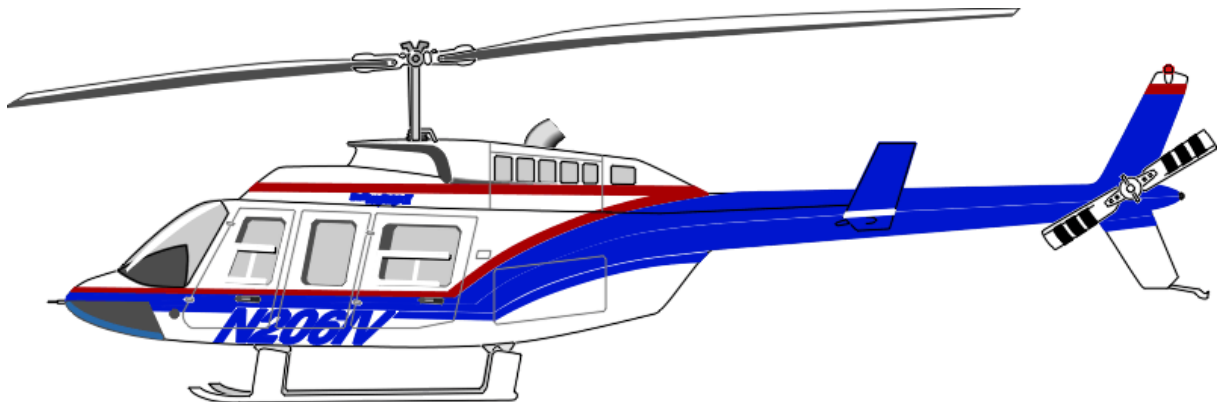

**THIS HANDBOOK INCLUDES THE MAINTENANCE INFORMATION REQUIRED TO
BE AVAILABLE BY FAR PART 27**

NOTE

206L4 service Instructions are applicable to 206L1 rotorcraft that have been modified IAW BHT-206-SI-2050 engine upgrade and BHT-206-SI-2052 increased gross weight Mod and 206L3 rotorcraft that have been modified IAW BHT-206-SI-2052 increased gross weight Mod.

RESTRICTED DISCLOSURE NOTICE

THIS PUBLICATION IS THE PROPRIETARY INTELLECTUAL PROPERTY OF AIR COMM CORPORATION AND IS DELIVERED TO THE RECIPIENT WITH THE EXPRESS CONDITION THAT IT AND THE INFORMATION CONTAINED HEREIN ARE NOT TO BE USED, DISCLOSED OR REPRODUCED IN PART OR IN WHOLE, FOR ANY PURPOSE WITHOUT THE EXPRESS WRITTEN CONSENT OF AIR COMM CORPORATION. NO RIGHT IS GRANTED TO THE RECIPIENT TO DISCLOSE OR SO USE ANY INFORMATION CONTAINED IN THIS DOCUMENT OUTSIDE THE PURPOSE FOR WHICH IT WAS DELIVERED. THESE RESTRICTIONS DO NOT OPERATE TO NULLIFY OR LIMIT ANY RIGHTS GRANTED BY CONTRACT.

RECORD OF REVISIONS

Rev	Date	Description of Change	Approval
A	03/07/05	Page II-1- Added data for evap blower motor change and correct dual fwd evap arm. ES61142-1 motor weighs .75 lbs more than ES61060-2 motor. Pg. 5- added Fasco motor to list. Revised pgs 17 and 18 to include both the ES61060-2 (Panasonic motor) and the ES61142-1 motor (Fasco)	N/A Prepared by GP
B	09/22/05	Part number ES61060-2 blower motor replaced With part number ES61064-1. Page 5 of 20.	N/A Prepared by GP
C	01/10/08	Part number ES57008-1 binary switch deleted and replaced with ES57178-1 binary switch. Pages I, 1 of 20, 4 of 20, 5 of 20, 17 of 20 and 18 of 20.	N/A Prepared by GP
D	10/06/08	Part number ES26112-4 Bypass Valve deleted and replaced with ES2619 Pages I, 1 of 20, 5 of 20, and 19 of 20.	N/A Prepared by GP
E	01/18/11	Re-formatted entire document to meet 8110.54. Added Note to bottom of cover and under applicability pg 0-1.	N/A Prepared by JB
F	02/23/11	S-6102EC-3 was S-6078EC-1, 3 Pls. S-6102EC-3 was S-6102EC-1, 1 Pls.	N/A Prepared by JB
G	03/21/11	Added (Remove/Replace) to Chapter 6.	N/A Prepared by JB
H	1/19/15	Minor ICA change to remove unnecessary definitions and correct inaccurate definitions (page 1, 2), clarify unit of measure (page 3), clarify definition (page 4), clarified and include inspection of blower electrical connectors (page 11-12), added alternate belt option (pages 12, 18,19, and 33), added notes to describe new placard changes, added new placard (page 20, 21), clarify refrigerant oil requirements (page 24), install and replace for wire harness for evap and condenser blowers, added component replacement oil amounts (page 25, 26), update torque values and information (page 27), update leak check location for details (page 28), clarify replace instructions (pages 29, 33, 34, 35, 37, 39, 40), added figure 18 (page 39), update Appendix A Weight and Balance (page 46), update format throughout document including figure number and page number updates, grammar, typographical errors, spelling, address change, etc. (rev bars for this change omitted). Updated revisions history page, List of Effective Pages and List of Revisions (rev bars for this change omitted).	Prepared By: <u>Karen G. Blecha (KGB)</u> <u>1/19/2015</u> Signature Date ACC Approval: <u>MDD</u> <u>3/15/2015</u> Signature Date FAA Acceptance (Major Change): <u>N/A – Meets Minor Change</u> <u>Agreement MR-100-134</u> <u>1/19/2015</u> Signature Date

INSTRUCTIONS FOR CONTINUED AIRWORTHINESS - 206EC-270M-1

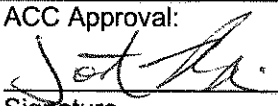
J	2/28/17	Updated washer part numbers on Figures 12 and 13: Is NAS1149F0563P Was AN960-516	Prepared By: <u>Cory Posvic</u> <u>2/28/2017</u> Signature Date ACC Approval: <u>Luke Bokas</u> <u>2/28/2017</u> Signature Date FAA Acceptance (Major Change): N/A – Meets Minor Change <u>Agreement MR-100-134</u> <u>2/28/2017</u> Signature Date
K	3/27/17	Added detail to reference Bell Helicopter Maintenance Manual for disconnect and reconnect of tail rotor drive shaft in sections 6.1-a and 6.2-a	Prepared By: <u>Luke Bokas</u> <u>3/27/17</u> Signature Date ACC Approval:  <u>3/27/17</u> Signature Date FAA Acceptance (Major Change): N/A – Meets Minor Change <u>Agreement MR-100-134</u> <u>3/27/17</u> Signature Date

LIST OF EFFECTIVE PAGES

LIST OF EFFECTIVE PAGES

<u>Title</u>	<u>Page(s)</u>	<u>Revision No.</u>
Record of Revisions	iii	J
List of effective Pages	iv	J
Table of Contents	v-vi	J
Chapter 1 Introduction	1-6	J
Chapter 2 Airworthiness Limitation Section	7	J
Chapter 3 Inspections	8-12	J
Chapter 4 Location and Access	13-20	J
Chapter 5 Placards and Markings	21-23	J
Chapter 6 Servicing	24-26	J
Chapter 7 Standard Practices	27-42	J
Chapter 8 Troubleshooting	43-46	J
Appendix A		
Weight and Balance information	47	J

TABLE OF CONTENTS

<u>CHAPTER</u>	<u>PAGE</u>
CHAPTER 1	1
INTRODUCTION	1
1. SCOPE.....	1
2. PURPOSE.....	1
3. ARRANGEMENT	1
4. APPLICABILITY	1
5. DEFINITIONS	1
6. ABBREVIATIONS	2
7. PRECAUTIONS	3
8. UNITS OF MEASUREMENT.....	3
9. INFORMATION ESSENTIAL TO THE CONTINUED AIRWORTHINESS OF THE AIR CONDITIONER.....	3
10. REFERENCE DOCUMENTS	3
11. DISTRIBUTION.....	3
12. CHANGES TO INSTRUCTIONS FOR CONTINUED AIRWORTHINESS.....	4
13. SYSTEM DESCRIPTION AND OPERATION	4
14. DESCRIPTION OF THE VAPOR CYCLE AIR CONDITIONER AND ITS INSTALLATION.....	4
15. Refrigeration Cycle Schematic	6
CHAPTER 2	7
AIRWORTHINESS LIMITATION SECTION	7
CHAPTER 3	8
INSPECTIONS	8
1. INSPECTION REQUIREMENTS:	8
2. INSPECTION PROCEDURES.....	9
3. COMPONENT OVERHAUL / REPLACEMENT SCHEDULE	12
CHAPTER 4	13
LOCATION AND ACCESS	13
1. LOCATION OF AIR CONDITIONER FEATURES	13
CHAPTER 5	21
PLACARDS AND MARKINGS.....	21
CHAPTER 6	24
SERVICING	24
1. CHARGING PROCEDURE	24
2. REFRIGERANT PRESSURE.....	24
3. SAFETY PRECAUTIONS	24
4. TOOLS, EQUIPMENT, AND CONSUMABLES.....	25
CHAPTER 7	27
STANDARD PRACTICES	27
1. O-RING TYPE FITTINGS.....	27
2. SYSTEM LEAK CHECK.....	28
3. TORQUE SEAL.....	28
4. INSTALLATION & REPLACEMENT OF THE WIRE HARNESS ELECTRICAL CONNECTORS FOR THE EVAPORATOR AND CONDENSER BLOWERS.....	28
5. REMOVE AND REPLACE COMPRESSOR (Figure 11)	30

6. REMOVE AND REPLACE COMPRESSOR DRIVE BELT (Figure 12).	31
7. REMOVE AND REPLACE COMPRESSOR DRIVE PULLEY (Figure 12)	35
8. REMOVE AND REPLACE FORWARD EVAPORATOR (Figure 14)	35
9. REMOVE AND REPLACE AFT EVAPORATOR (Figure 15)	36
10. REMOVE AND REPLACE AFT EVAPORATOR BLOWER (Figure 15)	37
11. REMOVE AND REPLACE CONDENSER BLOWER ASSEMBLY (Figure 16 and Figure 17)	38
12. REMOVE AND REPLACE CONDENSER HEAT EXCHANGER (Figure 18)	38
13. REMOVE AND REPLACE BYPASS VALVE (Figure 19).	41
14. REMOVE AND REPLACE BINARY SWITCH (Figure 19)	41
CHAPTER 8	43
TROUBLESHOOTING	43
1. System Troubleshooting	43
2. ELECTRICAL	43
3. SYSTEM CHARGE	44
4. EXPANSION VALVE MALFUNCTION	44
5. COMPRESSOR MALFUNCTION	44
6. SYSTEM LEAK CHECK	44
APPENDIX A	47
WEIGHT AND BALANCE DATA	47

CHAPTER 1

INTRODUCTION

1. SCOPE

The scope of this manual encompasses the scheduled and unscheduled maintenance procedures for the continued airworthiness of the Air Comm Corporation air conditioning system installed in the Bell 206L4 series helicopter.

2. PURPOSE

The purpose of this manual is to provide the aircraft mechanic in the field the necessary information to maintain the air conditioning system.

3. ARRANGEMENT

This manual is arranged by chapters which are broken down into paragraphs and sub-paragraphs. All of the chapters and paragraphs are listed in the front of this manual in the Table of Contents, and are further identified by their individual page number.

4. APPLICABILITY

This manual is applicable to Bell Helicopter 206L4 models that are equipped with the Air Comm Corporation kit number 206EC-210 air conditioner system.

NOTE

206L4 service Instructions are applicable to 206L1 rotorcraft that have been modified IAW BHT-206-SI-2050 engine upgrade and BHT-206-SI-2052 increased gross weight Mod and 206L3 rotorcraft that have been modified IAW BHT-206-SI-2052 increased gross weight Mod.

5. DEFINITIONS

The following terms are provided to give a ready reference to the meaning of some of the words contained within this manual. These definitions may differ from those given by a standard dictionary.

Ambient air temperature: The temperature of the air surrounding a person or object.

Charging station: An air conditioning system service unit capable of evacuating and charging an air conditioner.

Condensation: The process of changing a vapor into a liquid.

Desiccant: A material used in the receiver/drier bottle, designed to absorb moisture from the refrigerant.

Glazing: A shiny coating caused by excessive heat.

Heat load: The amount of heat which the air conditioner is required to remove from the aircraft cabin.

Inches of mercury: A measurement of pressure, normally used for pressures below atmospheric, one inch of mercury is equal to approximately one half pound per square inch.

Pressure, ambient: The pressure of the air surrounding a body, normally measured in Pounds Per Square inch gauge, or PSIG.

Refrigerant: A fluid which is used in an air conditioning system to absorb heat from the cabin and carry it outside the helicopter where it can be transferred to the outside air.

Relative humidity: The ratio of the amount of water vapor in the air to the amount of water vapor required to saturate the air at the existing temperature.

Thermostat: An air conditioning control which senses the temperature of the evaporator coil and causes the system to cycle or by-pass to maintain the proper temperature of cooling air.

Vacuum: A negative pressure, or pressure below atmospheric; it is usually expressed in inches of mercury.

Vapor: The gaseous state of a material.

6. ABBREVIATIONS

InHg: Inches of Mercury

Lbs: Pounds

oz: Ounces

Psig: Pounds Per Square Inch (gauge)

gr: Grams

kg: Kilograms

Kg/cm: Kilograms Per Centimeter

ml: Milliliters

mm: Millimeters

Nm: Newton-meters

7. PRECAUTIONS

The following precautions are found throughout this manual, and will vary depending on the seriousness of the Hazard or Condition:

WARNING: May be a maintenance procedure, practice, condition, etc., which could result in personal injury or loss of life.

CAUTION: May be a maintenance procedure, practice, condition, etc., which could result in damage or destruction of equipment.

NOTE: May be a maintenance procedure, practice, condition, etc., or a statement which needs to be highlighted.

8. UNITS OF MEASUREMENT

All measurements contained within this manual are generally given in the United States standard measurement, with metric conversions in parentheses as needed.

9. INFORMATION ESSENTIAL TO THE CONTINUED AIRWORTHINESS OF THE AIR CONDITIONER.

This manual provides information which is required for operation and maintenance of the Air Comm air conditioning system installed in the Bell model 206L series helicopter. After completion of the air conditioner installation this document must be placed with the appropriate existing aircraft documents.

10. REFERENCE DOCUMENTS

The approval basis of the system covered by this ICA is Supplemental Type Certificate **SH2750NM**

11. DISTRIBUTION

This document is to be placed with the aircraft maintenance records at the time of system installation.

Changes will be made to this document in response to “Safety of Flight”, and or “Non-safety of Flight” issues. Any changes will result in a revision to this document. Revisions shall be noted in the Record of Revisions (page iii), and on the List of Effective Pages (page iv) of this manual.

In addition to the revision of the manual, those changes categorized as “Safety of Flight” shall have a Service Bulletin issued to the operator providing the necessary information to comply with, and or to correct, the “Safety of Flight” issue.

Replacement, and or revised copies of this manual may be obtained by contacting:

Air Comm Corporation Service Department
1575 W. 124th Ave STE 210
Westminster, CO.80234
Phone No. 303-440-4075 Fax No. 303-440-6355
INFO@aircommcorp.com

12. CHANGES TO INSTRUCTIONS FOR CONTINUED AIRWORTHINESS

Changes made to a line or paragraph of this document will be indicated by a vertical bar in the right hand margin, while a complete page change will be indicated by a vertical bar next to the page number.

(Example: Any change will appear with a vertical bar next to that change). 

13. SYSTEM DESCRIPTION AND OPERATION

The 206EC-206 system is a vapor cycle type Air Conditioner consisting of a Compressor, Condenser, Dryer, By-pass valve, and Multiple Evaporator assemblies.

The Compressor is belt driven off of the tail rotor drive shaft, which is located in the engine compartment.

The Condenser assembly is located below the baggage compartment floor. Cooling air is forced through the condenser by a 28V DC electric blower, and an electrically actuated scoop that opens and closes when the system is switched from OFF to ON to OFF.

Each evaporator assembly contains a 28V DC, two speed electric blower that allows the system to be switched to either a High or Low setting.

A refrigerant gas by-pass valve is located aft of the baggage compartment. The purpose of this valve, (which is set at the factory) is to prevent evaporator heat exchanger freeze-up by controlling the minimum evaporator pressure (temperature).

The system incorporates a binary high/low pressure “cut-out” switch. This switch is intended to protect the compressor in case of system over-pressure or loss of refrigerant. The switch is located adjacent to the system charging ports (Aft of the baggage door on the L/H side of the aircraft) and is wired in series with the compressor clutch.

Switch operating pressures:

Low Pressure function –
Open @ 28 ± 2.8 psi
Close @ 29 ± 4.3 psi
High Pressure function –
Open @ 384 ± 30 psi
Close @ 289 ± 43 psi

14. DESCRIPTION OF THE VAPOR CYCLE AIR CONDITIONER AND ITS INSTALLATION

This section contains a general overview of a Vapor-cycle air conditioning system and how it functions. This type of system operates in a closed loop, in which the refrigerant absorbs heat from the cabin, and rejects it into the outside air. The refrigerant then returns to the cabin to repeat the cycle. The operation of the system is described below, and illustrated schematically in Figure 1.

Liquid refrigerant is contained in the receiver-drier under pressure from the compressor. The receiver-drier also filters the refrigerant through a material know as desiccant. The desiccant ensures that the fluid leaving this component is free of any water or other contaminants.

The low pressure (suction) line from the compressor is attached to the evaporator lines, and causes the refrigerant to be pulled out of the receiver-drier and through the expansion valves. The expansion valves serve as a controlled spray orifice, to spray the correct amount of refrigerant into the evaporator.

This regulation of refrigerant allows the liquid to absorb the heat from the cabin air, and transform it to a vapor state just prior to its exiting the evaporator assembly.

The low pressure vapor is then drawn into the compressor where its pressure is raised to approximately 200 psi (14.06 kg/cm), and its temperature to around 200° F (93.3° C) this high pressure / high temperature vapor then travels to the condenser, (a heat exchanger cooled by a flow of outside air). Heat is extracted from the refrigerant, and as it cools it condenses back into a liquid and flows into the receiver-dryer, ready to repeat the cycle.

15. Refrigeration Cycle Schematic

(PLEASE NOTE: This illustration is provided as a reference only and may not match actual installation)

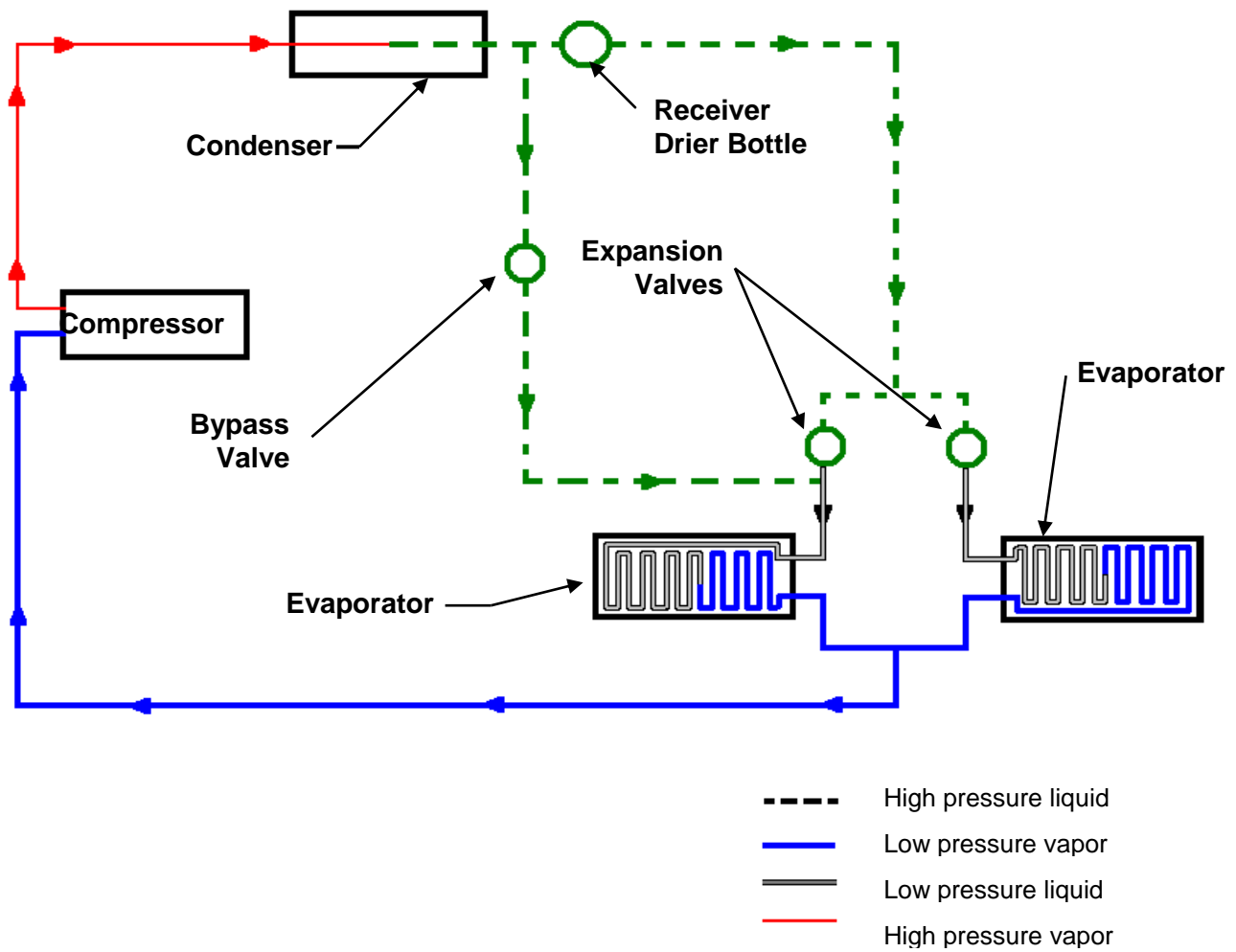

Figure 1: Refrigeration Cycle Illustration

CHAPTER 2

AIRWORTHINESS LIMITATION SECTION

The Airworthiness Limitations section is FAA approved and specifies maintenance required under paragraph 43.16 and 91.403 of the Federal Aviation Regulations unless an alternate program has been FAA approved.

1. Airworthiness Limitations

No airworthiness limitations associated with this design change

CHAPTER 3

INSPECTIONS

1. INSPECTION REQUIREMENTS:

Periodic Inspections
(Hours Are Aircraft time)

Item	Annual	Every 200 hours of operation	Special inspection instructions.
Fwd Evaporator Blower	X		Check for operation throughout entire speed range of blower operation.
Aft Evaporator Blower	X		Check for operation throughout entire range of speed for blower operation.
Condenser blower motor and fan Assy	X		Check for operation.
Compressor Drive Belt	X	X	Check for signs of excessive wear (Example: Glazing, Cracks and Exposed Fibers).
Air conditioner Placards and markings	X		Check for security and legibility.
Compressor Assy.	X	X	Check for Operation, Security of attaching hardware and signs of refrigerant or oil leaks.
Compressor Mount	X	X	Check for cracks and security of attaching hardware.
Plumbing and Fittings	X	X	Check for security and signs of oil or refrigerant leaks
Air Conditioner Compressor drive pulley	X	X	Check for security of attaching hardware
Blower Electrical Connectors	X		Visually inspect for signs of overheating

2. INSPECTION PROCEDURES.

NOTE

Refer to "Chapter 4 Location and Access" to locate all components for inspection.

A. Inspection of the FWD and AFT evaporator blower motors

CAUTION

Fans are designed to operate with the resistance of the entire ducting system. Operation of the evaporator fans with any part of the distribution system removed may cause permanent damage to the fan motor.

WARNING

Fans may take up to 10 seconds to start after the switch is turned on. Keep hands away from fan whenever switch is in "Fan" or "A/C" positions.

- a. At the Cockpit's Air Conditioner Control Panel place the AIR COND switch in the FAN position and verify that:
 1. both the fwd and aft fans are activated and operating – Place blower switches to "low" and "high" to verify blowers increase and decrease speed accordingly.
 2. the condenser fan is non-operational.
 3. the compressor clutch is disengaged.
- b. Place the AIR COND switch on the OFF position and verify that:
 1. both the fwd and aft fans deactivate
 2. the compressor clutch remains disengaged.

B. Inspection of the air conditioner condenser

NOTE

This inspection may be performed with the air conditioner charged with refrigerant or it may be performed with no refrigerant in the system. In the case where there is no refrigerant in the system or the system is low on refrigerant or in the case where the ambient temperature is low, the binary switch will need to be jumpered. The temporary installation of a jumper wire across the terminals of the binary switch will do no harm even if it was not necessary.

CAUTION

THE TEMPORARY JUMPER **MUST** BE REMOVED AFTER THIS INSPECTION IS COMPLETED.

- a. Visually inspect condenser air inlet for any obstructions or debris. Airflow in this area is critical for air conditioner operation.
- b. Install a jumper between the contacts of the binary switch if required.

- c. Connect 28V ground power to the aircraft and place the A/C mode switch in the "A/C" position and verify that:
 - 1. Condenser scoop opens.
 - 2. Condenser fan is activated and operating. This fan should pull air into the aircraft through the open scoop and exit at the screen below the condenser.
 - 3. Compressor clutch is engaged. Verify compressor clutch engagement by visually observing the clutch plate clamp to the compressor rotor or an audible click when the switch is moved to "on".
- d. Place the A/C mode switch into the Off position and verify that:
 - 1. The condenser fan is deactivated.
 - 2. The condenser scoop closes.
- e. Ensure that the jumper wire is removed from the binary switch

CAUTION

This procedure requires the temporary installation of a jumper wire across the terminals of the binary switch. This wire **MUST** be removed after this inspection is accomplished.

- f. Visually inspect condenser air inlet for any obstructions or debris. Airflow in this area is critical for air conditioner operation.
- g. Install a jumper between the contacts of the binary switch.
- h. Connect 28V ground power to the aircraft and place the A/C mode switch in the "A/C" position and verify that:
 - 1. Condenser fan is activated and operating. This fan should pull air into the aircraft through the condenser assy.
 - 2. Compressor clutch is engaged.
- i. Disconnect one of the electrical leads from the binary switch, remove jumper wire and:
 - 1. Reconnect the electrical lead removed from the binary switch.
- j. Place the A/C mode switch into the Off position and verify that:
 - 1. The condenser fan is deactivated.

C. Inspection of compressor drive belt

- a. Remove transmission cowling to gain access to compressor drive belt and visually inspect the A/C compressor drive belt for the following:
 - 1. Any signs of excessive wear.
 - 2. Any signs of glazing.
 - 3. Any cracks or missing pieces.
 - 4. Any exposed fibers.
- b. Verify proper belt tension as shown in the illustration shown in Figure 2.

The proper belt tension is achieved using the following procedures:

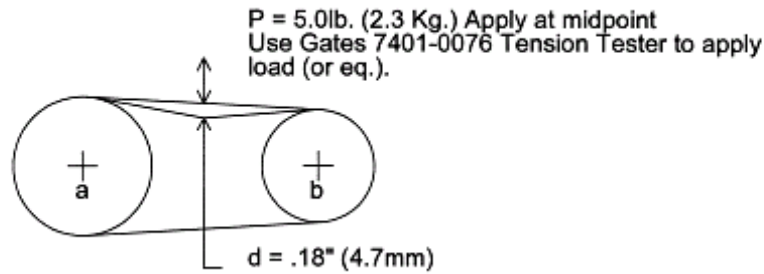

Figure 2: Belt Tension Inspection

D. Inspection of air conditioner placards and markings.

- a. Check all air conditioner placards and markings for security and legibility.

E. Inspection of air conditioner compressor assembly

NOTE:

The air conditioning system must be serviced with refrigerant to perform this inspection.

- a. Connect 28V ground power to the aircraft and place the A/C mode switch in the "A/C" position and verify that :
 1. The compressor clutch is engaged.
- b. Place air conditioner switch to the OFF position and verify that:
 1. The compressor clutch is disengaged.
- c. Visually inspect the compressor assembly for the following:
 1. Security of all attaching hardware.
 2. Signs of refrigerant or oil leaks.
 3. Signs of excessive belt slippage or excessive heat.

F. Inspection of Air Conditioner Compressor Mount Assy.

- a. Visually inspect compressor mount for any signs of the following:
 1. Any cracks.
 2. Security of attaching hardware (loose hardware).
 3. Elongation of component mounting holes.
 4. Any loose rivets.

G. Inspection of Air Conditioner Refrigerant Plumbing.

- a. Visually inspect plumbing and fittings for any signs of the following:
 1. Refrigerant gas or oil leaks.
 2. Chaffing or excessive corrosion.
 3. Security of attaching hardware.

H. Inspection of Compressor Drive system

- a. Cut the safety wire on the belt tensioning link assembly jam nuts and adjust the tensioning link assembly to loosen the compressor drive belt.
- b. Check S-3520 drive pulley for play relative to the tail rotor drive shaft, both in the direction of rotation as well as for lateral movement relative to the shaft, and inspect area around the base of the drive ring at the shaft for any buildup of metal dust/powder residue.
- c. If there is any detectable looseness, and/or if there is significant metal dust/powder residue present, refer to Section 8 for removal instructions to allow removal and further inspection to determine if the pulley or drive ring need to be replaced.
- d. If there is no detectable looseness, and no significant metal dust/powder residue present, re-tension the belt per Section 8.
- e. Check security and condition of all related fasteners.

I. Inspection of Blower Electrical Connectors

- 1. Locate the electrical connectors that power the evaporator and condenser blowers. The connectors are at the interface between the blower harness and the aircraft harness and identified by their white plastic housing.

Note:

For 206EC-208 AC kits the evaporator blowers have an additional connector to inspect located several inches away from the harness connector.

- 2. De-mate each connector and inspect both mates for signs of overheating (discoloration or plastic deformation).
- 3. If any signs of overheating of the housing are present the system must be rendered inoperative and the connector housing and contacts replaced before further operation.

3. COMPONENT OVERHAUL / REPLACEMENT SCHEDULE

COMPONENT OVERHAUL / REPLACEMENT SCHEDULE

Part Number	Description	Recommended replacement
ES61064-1	Forward Evaporator Blower Motor	On Condition
ES61142-1	Aft Evaporator Blower Motor	On Condition
ES73186-1	Condenser Blower motor	On Condition
7270, 7265 ALT.	Compressor Drive Belt	On Condition
S-6008EC-6	Compressor	On Condition

CHAPTER 4

LOCATION AND ACCESS

1. LOCATION OF AIR CONDITIONER FEATURES

Nomenclature	Description of Location
Air Conditioner Control Panel	The air conditioner control panel is located in the existing overhead circuit breaker panel between the pilots and co-pilots seats.
Forward (Flight Deck) Evaporators	The forward evaporator(s) are mounted to the center pedestal below the instrument panel in the chin bubble area
Aft (Main Cabin) Evaporator	The aft evaporator(s) are located aft of the hat shelf above the baggage compartment.
Condenser Assembly	The condenser assembly is located below the baggage compartment floor. The condenser may be accessed from below the cabin aft of the rear landing gear cross tube.
Compressor Assy	The compressor assembly is mounted on the forward left hand side of the rear engine firewall and is driven off the oil cooler impeller shaft.
Refrigerant Plumbing	The refrigerant plumbing is routed from the compressor, to the condenser and all the other components. (As the refrigerant plumbing connects the compressor, condenser and evaporators, it may be necessary to remove several panels to gain access to its components)
Servicing Ports	The air conditioning service ports are located on the opposite wall of the baggage compartment.

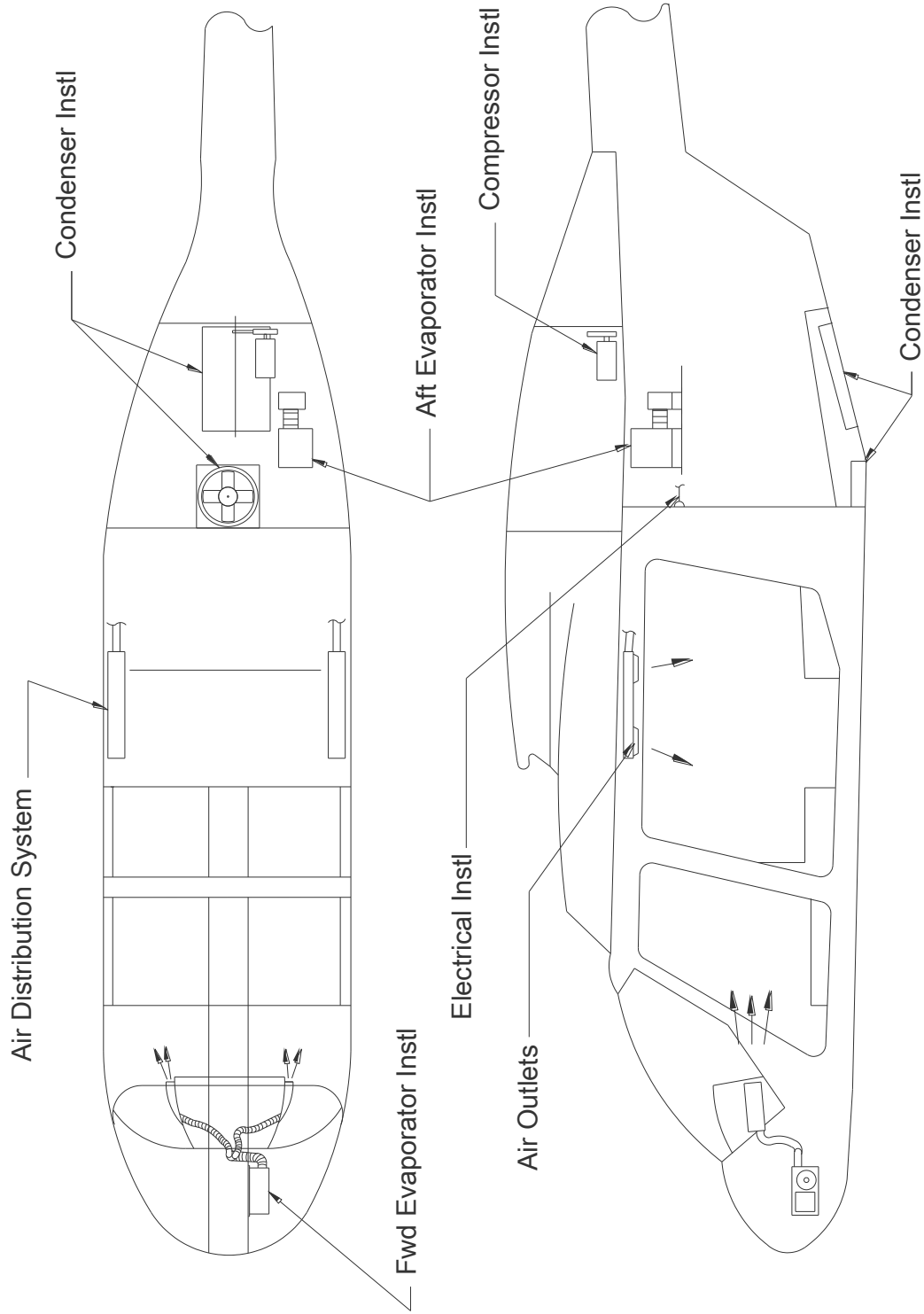

**Figure 3: Layout of Air Conditioning
Single Fwd Evaporator**

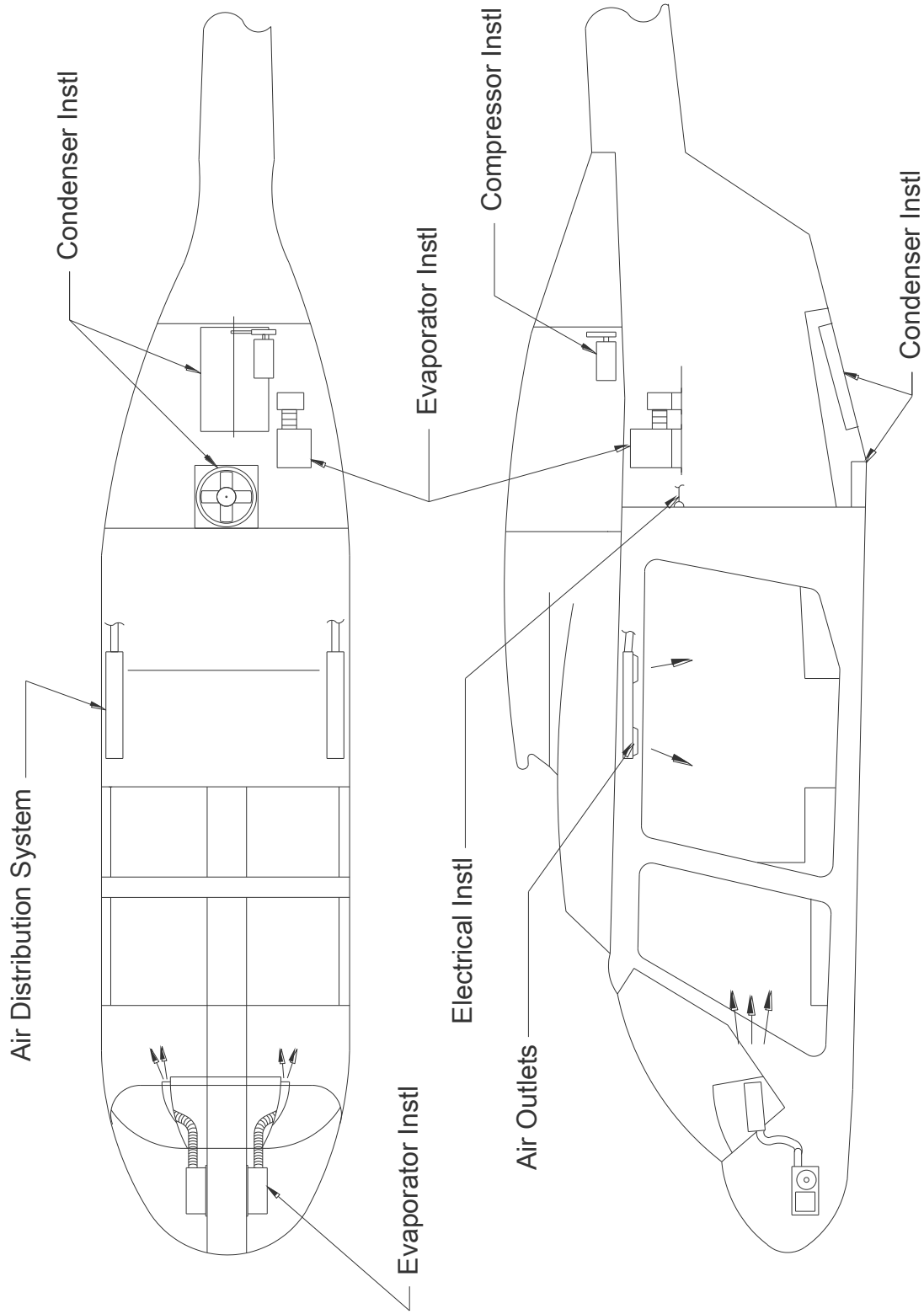

Figure 4: Layout of Air Conditioning Dual Fwd Evaporators

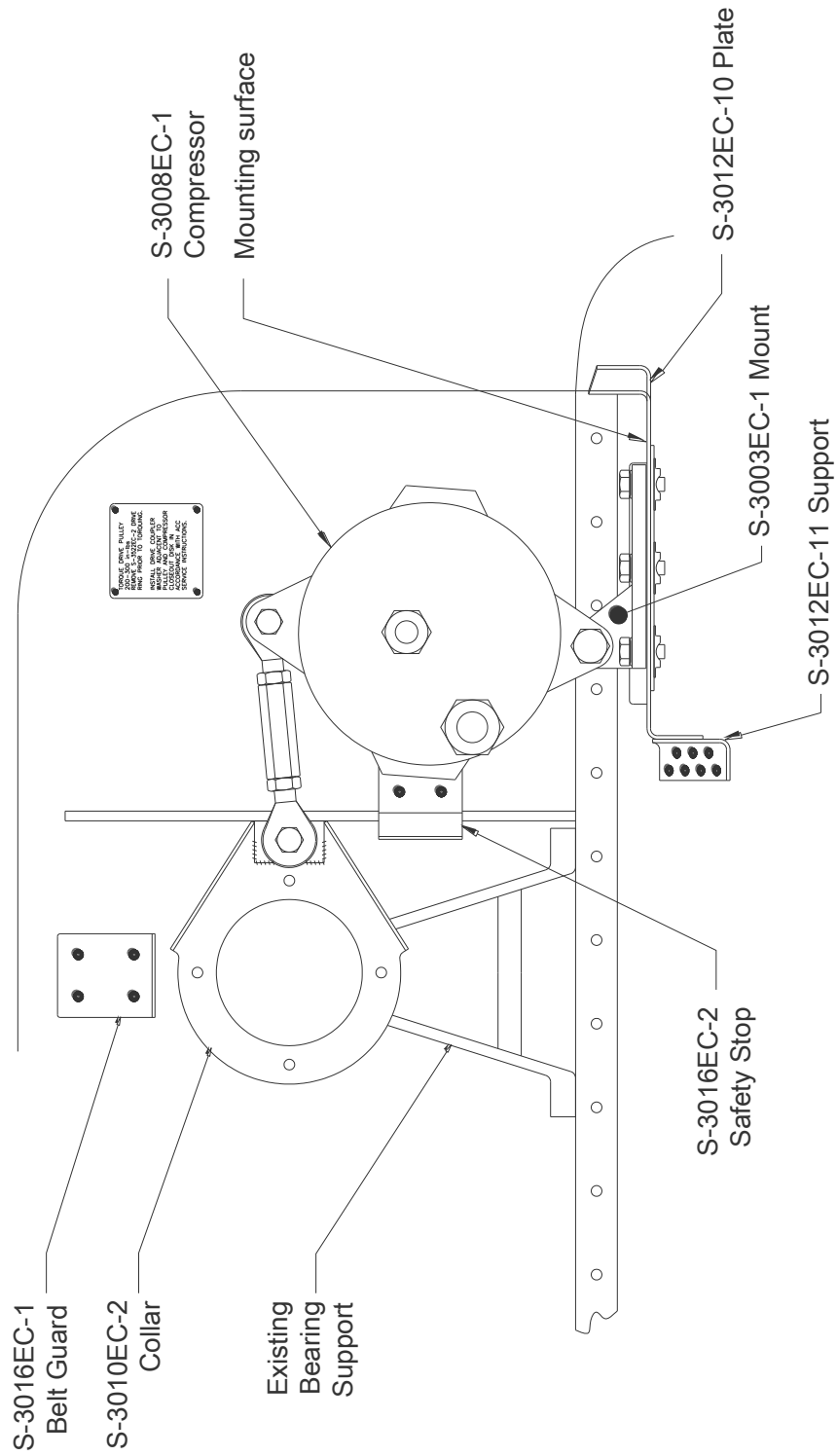

Figure 5: Compressor Assy Looking Aft

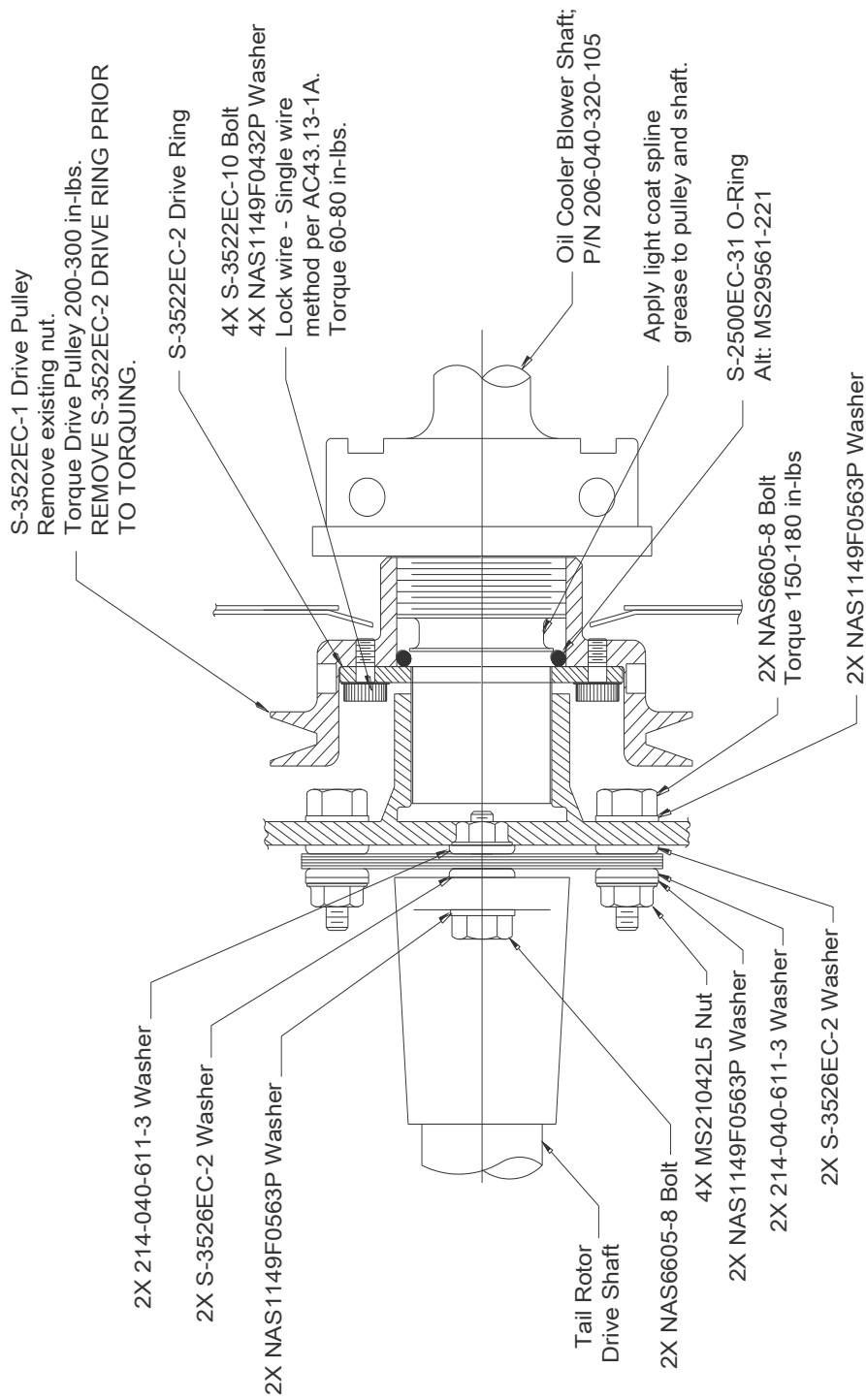
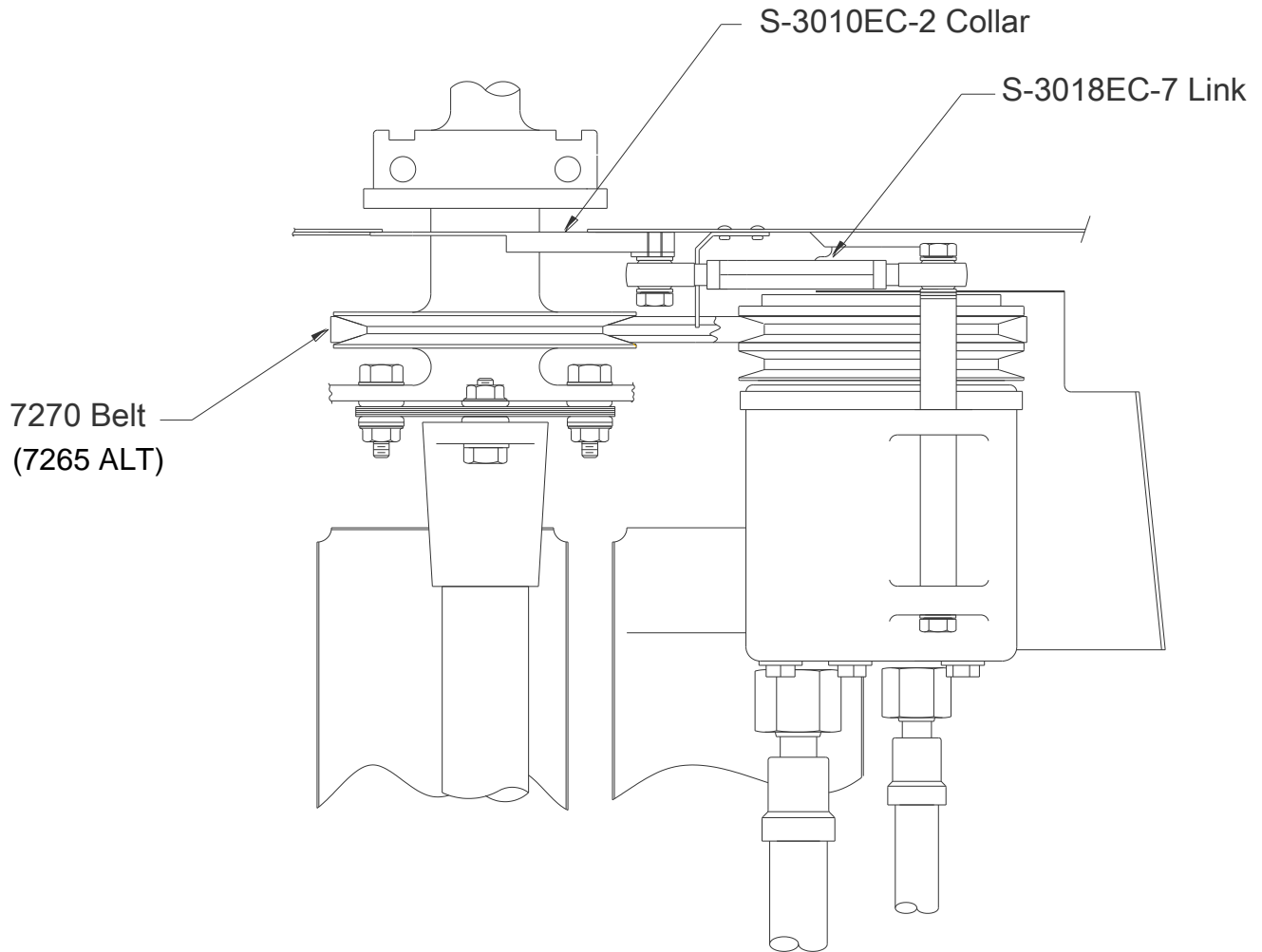

Figure 6: Detailed View of Compressor Pulley



**Figure 7: View of
Compressor Drive**

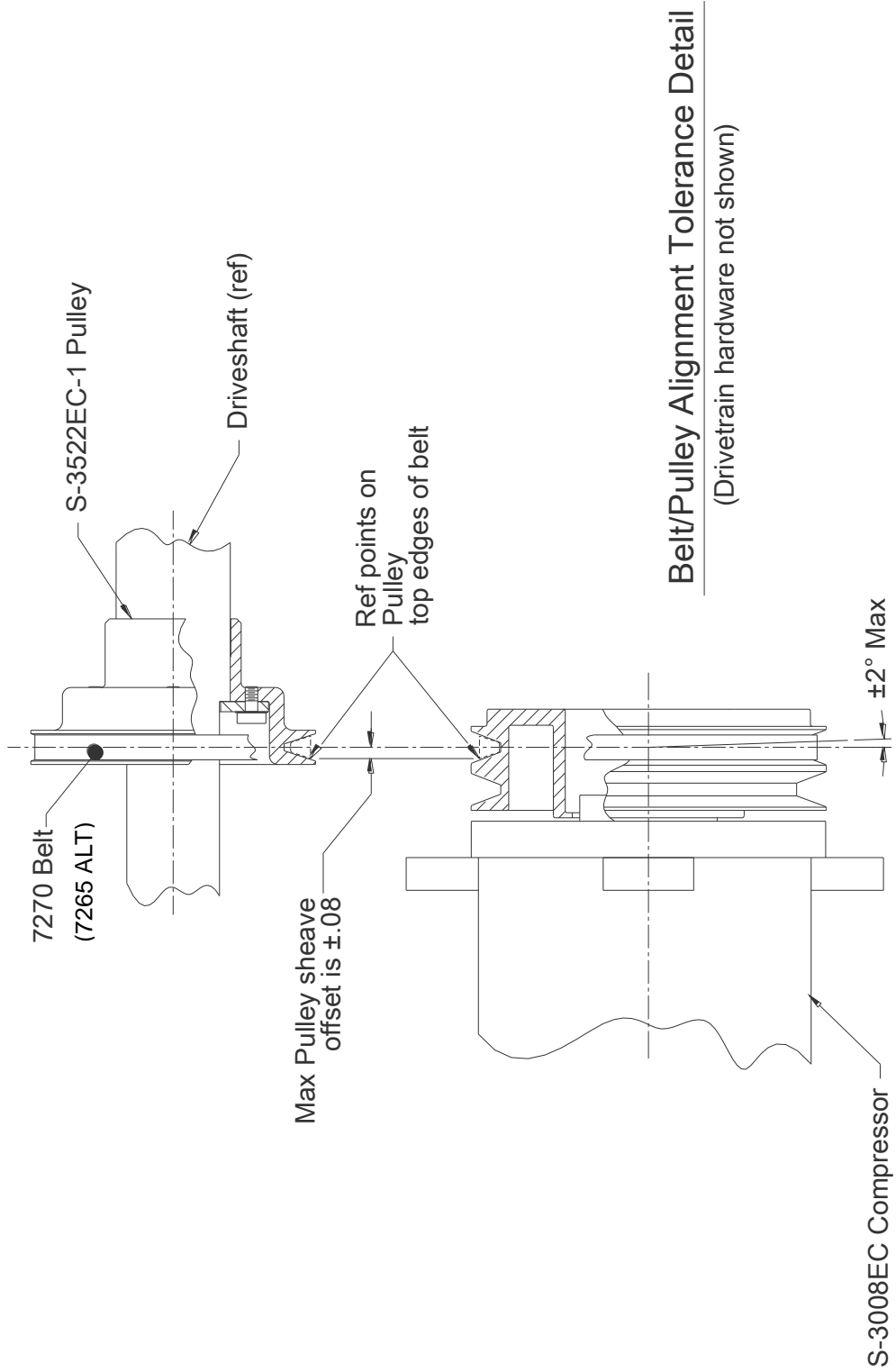

Figure 8: Compressor Belt Alignment

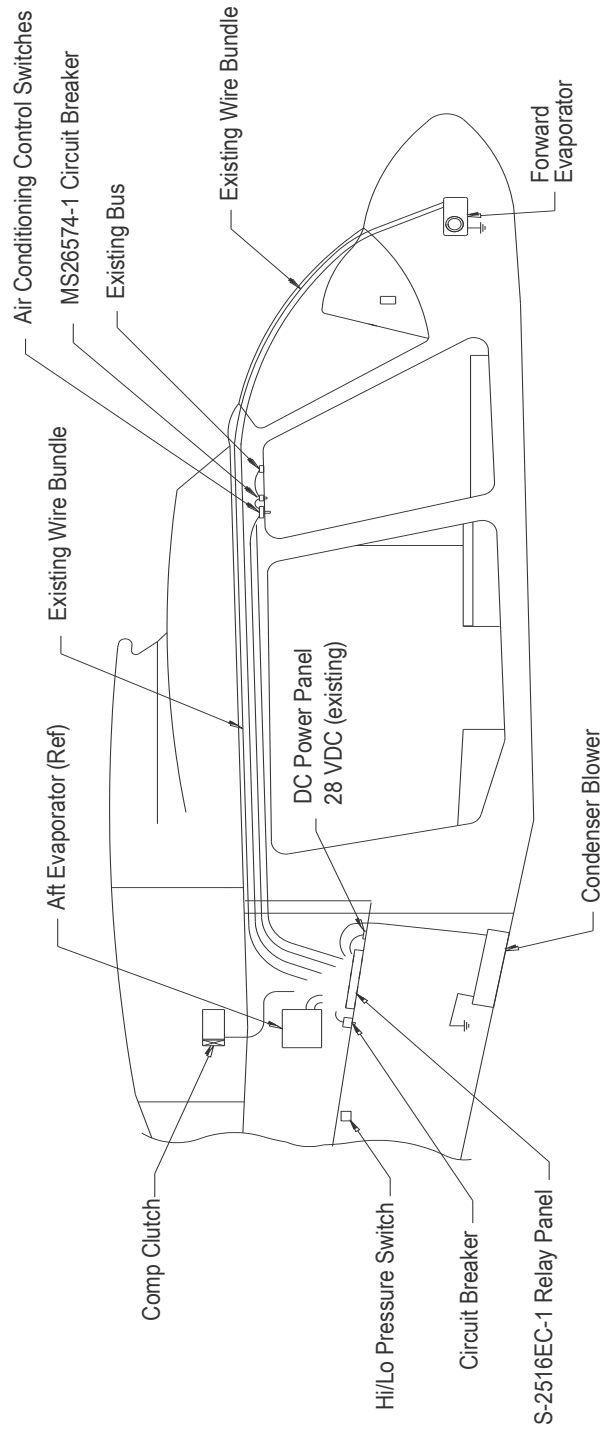

Figure 9: Electrical system components

CHAPTER 5

PLACARDS AND MARKINGS

SYSTEM CHARGING INSTRUCTIONS

SYSTEM TO BE SERVICED BY QUALIFIED PERSONNEL
 R134a Refrigerant-Polyester oil-XH9 Desiccant

System charge: lbs.

If exact weight of refrigerant charge is not known, use following procedure:

- o Charge system in .25 lb increments until minimum outlet temperature & system suction pressure is achieved.
- o Allow several minutes after each charge increment, to allow temperature & pressure to stabilize.

The following data is provided as reference information. System pressures can vary from this table depending on Temperature/Humidity relationships.

<u>Ambient Temp F</u>	<u>High Pressure Gauge Reading</u>	<u>Suction Gage Reading</u>
55	95-115	30-40
60	105-125	
65	115-135	
70	130-150	
75	150-170	
80	165-185	
85	175-195	
90	185-205	
95	210-225	
100	220-240	
105	240-260	

**AIR COMM CORPORATION
BOULDER, COLORADO**

1. Placard S-2506-7 was used from October 1996 through mid -March 2001 and is displayed next to the service ports in the baggage compartment.

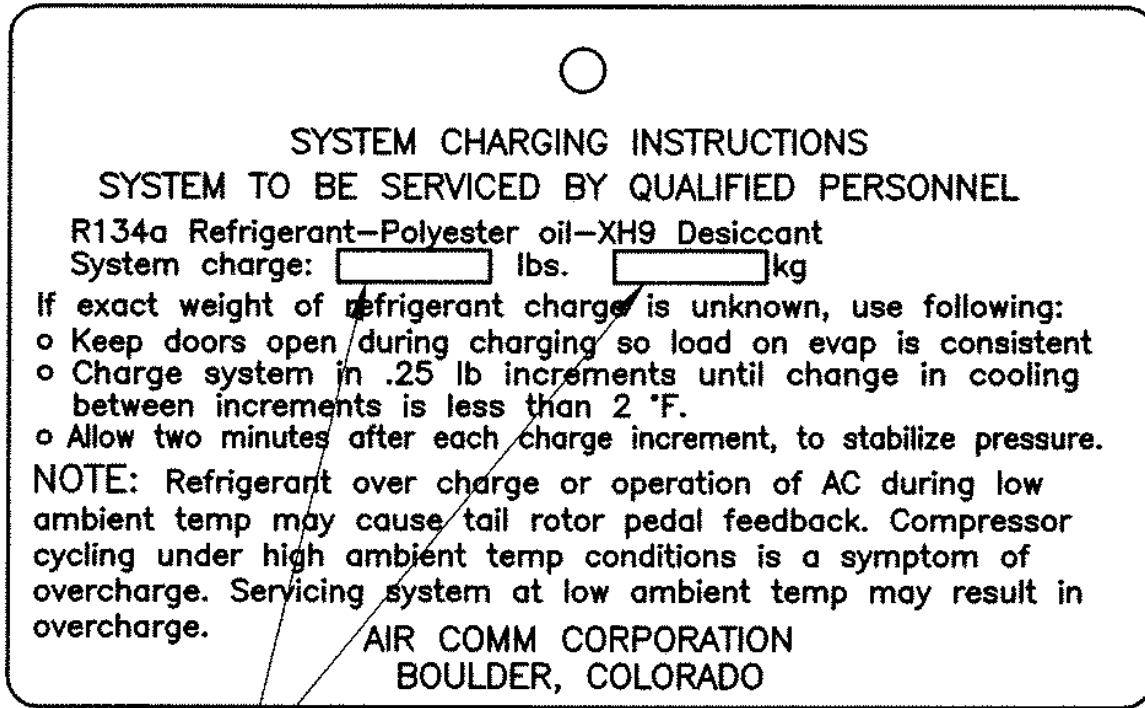

System Charge is 2.4 lb(1.1 kg) for Single Evap., 2.6 lb (1.2 kg) for Dual Evap.

The above placard was used from mid -March 2001 through 2014.

2. Placard S-2507EC-3/-4 is displayed next to the service ports in the baggage compartment.

NOTE

Newer systems do not include the "BOULDER, COLORADO" annotation on the System Charging Instructions Placard.

NOTE

Systems shipped in 2015 or later include both "Polyester oil" and "Ultra PAG oil" in the annotation on the System Charging Instructions Placard.

INSTRUCTIONS FOR CONTINUED AIRWORTHINESS - 206EC-270M-1

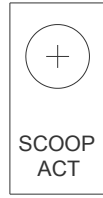

-24 Placard

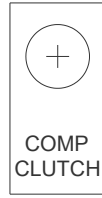

-25 Placard

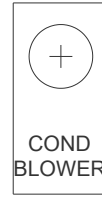

-26 Placard

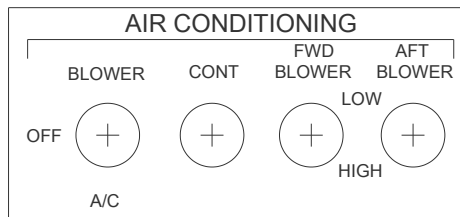

-28 Placard

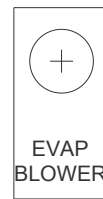

-27 Placard

2. The above placards must be displayed adjacent to the appropriate circuit breaker or switch on the overhead circuit breaker panel in the cockpit.

CHAPTER 6

SERVICING

1. CHARGING PROCEDURE

NOTE

This system should be serviced by **QUALIFIED PERSONNEL** only!

Leak check system in accordance with procedures in CHAPTER 7. Evacuate system for a minimum of 30 minutes. Charge the system with 2.4 lbs (single fwd. Evaporator) or 2.6 lbs (Dual fwd. Evaporator) of R134a refrigerant. System pressures can vary depending on temperature / humidity relationships. The **most effective** method of charging a system is to add an initial refrigerant charge of 2.0 lbs then continue to add refrigerant until the evaporator outlet air temperature and system suction pressure reaches a minimum and subsequently starts to increase. When adding the refrigerant after the initial charge it should be done in increments of .25 lbs, and a minimum of 10 minutes allowed to elapse before adding each additional .25 lbs of refrigerant charge. This allows the system to stabilize and reach its maximum cooling potential for the given charge. The optimum charge occurs when evaporator outlet air temperatures are at their lowest. Any additional refrigerant will cause the outlet air temperature to increase and system performance to be degraded. Charge the system to the point of noticing the first temperature increase, then reduce charge back to the optimum point where outlet air temperatures were lowest.

2. REFRIGERANT PRESSURE

System pressures will vary due to temperature and humidity relationships.

NOTE

**SYSTEM OVERCHARGING, OR OPERATION OF SYSTEM DURING
LOW AMBIENT TEMPERATURE CONDITIONS MAY RESULT IN
TAILROTOR PEDAL FEEDBACK!**

3. SAFETY PRECAUTIONS

The refrigerant used in the air conditioning system is HFC R134a. This refrigerant is non-explosive, non-flammable, non-corrosive, has practically no odor, and is heavier than air. Although R134a is classified as a safe refrigerant, certain precautions must be observed to protect parts involved and the person(s) working on the system.

Liquid R134a at normal atmospheric pressure and temperature evaporates so quickly that it will freeze anything that it contacts. Care must be taken to prevent any liquid refrigerant from coming in contact with the skin, especially the eyes. R134a is readily absorbed by most types of oil, therefore it is recommended a bottle of clean mineral oil and weak solution of boric acid be kept nearby when servicing the refrigerant system.

CAUTION

Always wear safety goggles when servicing any part of the refrigerant system. Should any liquid refrigerant get into the eyes, use a few drops of mineral oil to wash them out, then use a weak solution of boric acid to wash eyes, and seek aid from a doctor immediately even though the irritation has ceased.

It is important to keep the system tightly sealed because the refrigerant system is always under pressure. Heat applied to any part of the system will cause the pressure to build up excessively.

CAUTION

To avoid explosion, never weld, use a flame-type leak detector, blow torch, solder, stem clean, bake on aircraft finish, or use excess amounts of heat on, or in the immediate area of any part of the air conditioning system or refrigerant supply tank, while they are closed to the atmosphere.

4. TOOLS, EQUIPMENT, AND CONSUMABLES

- A. Service Equipment: (Suggested)
Recovery / Recycling / Recharging Station.
Robinair Model 34700 or Equivalent
Montpelier, OH
1-800-822-5561
- B. Electronic Leak Detector: (Suggested)
Micron – Tech III or Equivalent
Model 209907
Murray (NAPA)
- C. O-ring:

CAUTION

This system is charged with R134a Refrigerant and must be fitted with HSN O-rings (green in color).

D. Lubricant

CAUTION

This system may be serviced with either Polyolester (POE) or Double End Capped Polyalkylene Glycol (DEC PAG). Polyalkylene Glycol is preferred due to its superior lubricating properties and improved compressor service life. There are several types of PAG available. Only the “Double End Capped” type is permissible in Air Comm Corporation air conditioning systems. Double End Capped PAG oil is available from Air Comm Corporation in 8 ounce bottles (P/N ES94006-13). Mixing of POE and PAG is acceptable. Disregard previous statements to the contrary. They referenced PAG oil that was not “Double End Capped”. Current versions of compressors are designed to be operated using PAG oil. Testing by Air Comm Corporation has shown that “Double End Capped” PAG is compatible with POE and can therefore be mixed. **“Double End Capped”** is a reference to the chemical structure of the molecule and not to the container.

Do not use Mineral oil in this system with R134a refrigerant. Do not use any refrigerant oil other than Double End Capped Polyalkylene Glycol (also known as “ULTRA PAG”) or Polyolester (also POE).

Containers of DEC PAG or POE will absorb moisture if left open (hygroscopic). Keep containers tightly capped when not in use and keep all system components capped while servicing system.

The quantity of lubrication in the system is critical. If too little lubrication is in the system the compressor life may be reduced. No other component in the A/C system requires lubrication. Too much lubricant in the system will retard heat transfer in the evaporator and condenser coils and reduce the cooling capacity of the system.

The following chart may be used to calculate the amount of oil to be added in case a component is being replaced with a new part.

Component	Oil Amount
Compressor	See Instructions
Evaporator	1.0 oz. per evaporator
Condenser	1.5 oz.
Receiver Drier	1.5 oz.
Hose - Vapor	1.0 oz. per 10 foot
Hose – Liquid	1.0 oz. per 20 foot

E. Refrigerant: DuPont HFC R134a

SYSTEM REFRIGERANT & OIL CHARGE

System Description	Refrigerant Charge		Oil Charge	
	lbs.	kg.	fl oz.	ml.
206EC-210 Air Conditioner system, Single FWD evap	2.4 lbs.	1.1 kg.	8.0 fl oz.	238 ml.
206EC-210 Air Conditioner system, Dual FWD evap	2.6 lbs.	1.2 kg.	8.0 fl oz.	238 ml.

CHAPTER 7

STANDARD PRACTICES

1. O-RING TYPE FITTINGS

Shown below are the TORQ LOK® type fittings on the left and the insert O ring type fittings on the right. These two types of fittings are used throughout the refrigerant plumbing system. When connecting either type of fittings always lubricate the O-Rings with refrigerant oil before installing. Slide B-Nut back from end of tubing and inspect formed end of tube for defects. Confirm there are no nicks or debris on connection. Engage male end into female fitting being careful to maintain alignment and not pinch the O-Ring during this step. Hold fittings together while sliding the B-nut forward and engage threads. Tighten B-nut and to the following torque specifications. Always use a backup wrench while tightening the B-nut.

NOTE

TORQ LOK® fittings always use ES44012-(x) O-Rings and Insert O-Rings are ES44010-(x).

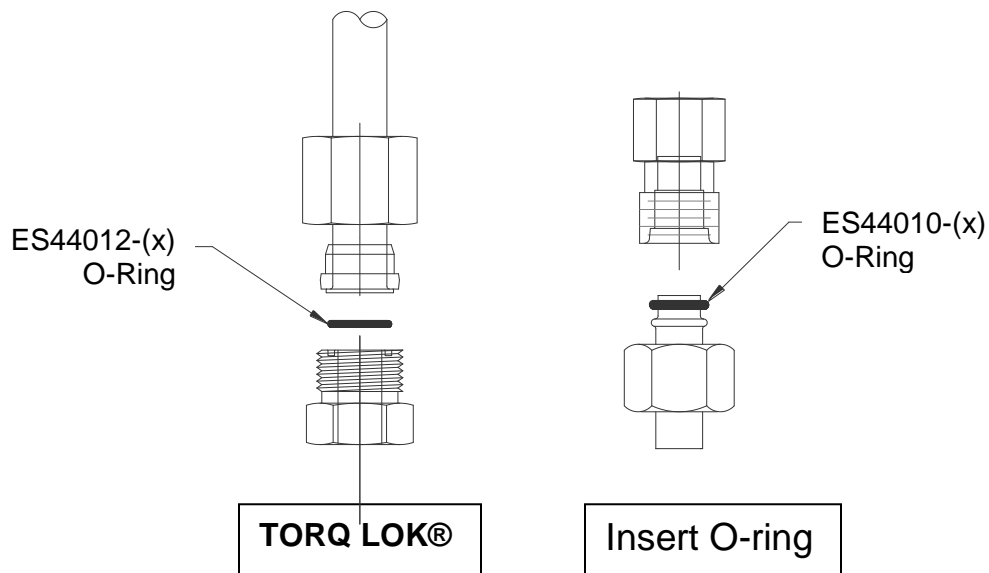

- TORQ LOK® Fittings: Must be hand snug (metal to metal) and then add an additional 30 degrees (one half flat).
- Insert O-Ring Fittings: Must be hand snug against O-ring, and then an additional 60 degrees (one flat).

CAUTION:

Excessive torque will damage fitting.

2. SYSTEM LEAK CHECK.

Identification and elimination of any system fitting leaks is extremely important to ensure a trouble free system. A system that contains a partial charge can be leak tested and recharged without evacuating the system. The system can be pressurized with nitrogen or R134a refrigerant. A system which has been evacuated should be filled to a pressure of at least 50 psig of refrigerant or 150 psig nitrogen prior to the leak survey (See CHAPTER 8).

3. TORQUE SEAL.

Once system is charged, check each fitting with an electronic leak detector. Once fittings have been checked and are leak free, torque Seal as appropriate.

4. INSTALLATION & REPLACEMENT OF THE WIRE HARNESS ELECTRICAL CONNECTORS FOR THE EVAPORATOR AND CONDENSER BLOWERS

To avoid potentially serious overheating issues the Molex style connectors (identified by their white plastic housing) installed on the aircraft harness for connecting to the evaporator and condenser blowers for kits prior to 2015 must be installed per ACC procedure PPP23 and only using the appropriate terminal crimp tool. This document is available on the ACC website www.aircommcorp.com/customer-support/service-manuals.

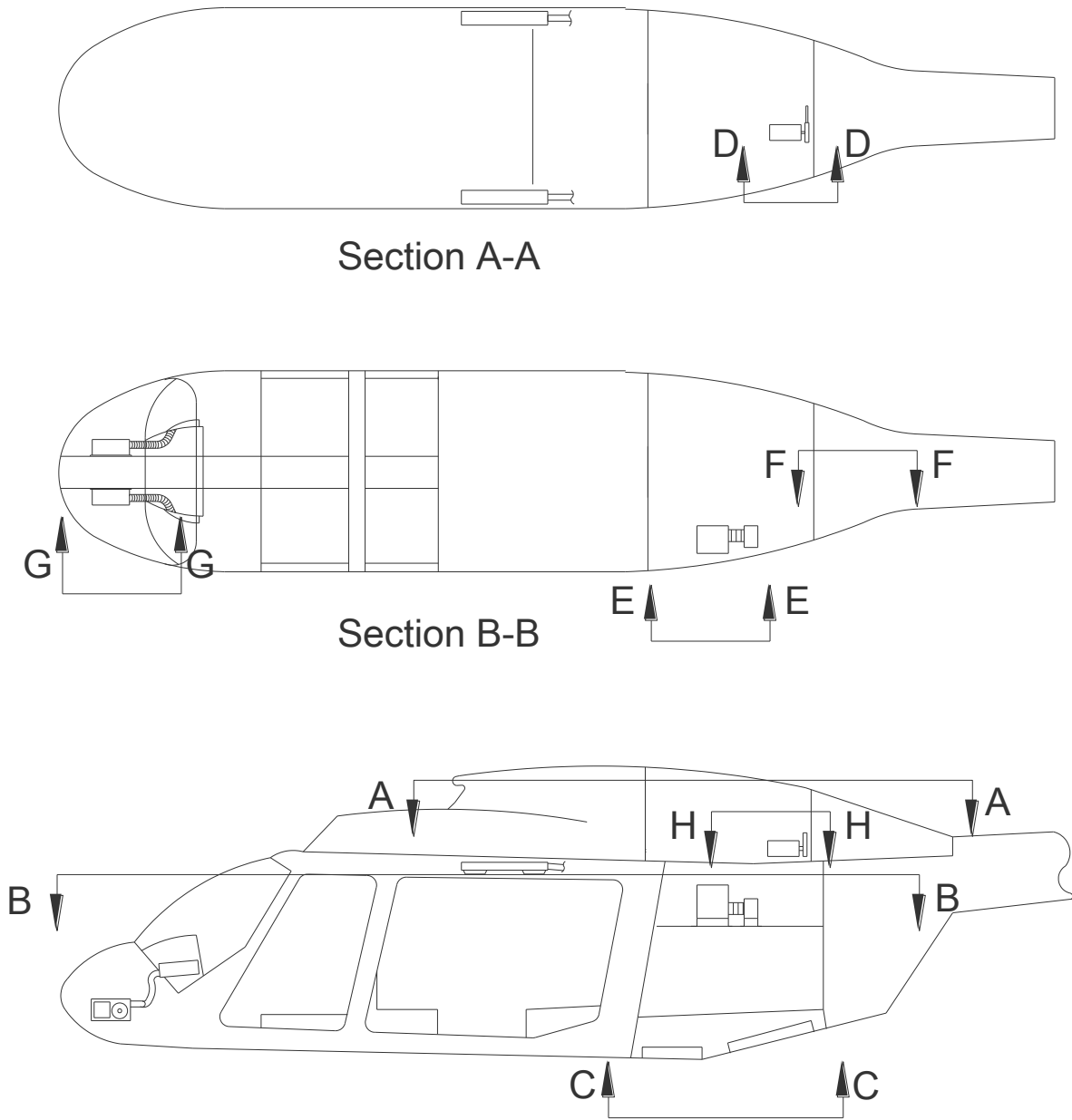

Figure 10: Air Conditioning System Component General Arrangement

5. REMOVE AND REPLACE COMPRESSOR (Figure 11)

5.1 REMOVE COMPRESSOR

- a. Recover refrigerant using Robinair Model 34700 or equivalent. Recover/Recycling/Recharge Station.
- b. Remove Suction and Pressure hoses from Compressor.
- c. Install caps and plugs over outlets and hoses.
- d. Remove safety wire from belt S-3018EC-7 Link turnbarrel.
- e. Remove inboard AN4 bolt from S-3018EC-7 Link.
- f. Remove AN6H34A bolt and washer from Compressor mount.
- g. Remove Compressor, then remove AN4H3A bolt and S-3001EC-12 rod.
- h. Retain S-3001EC-12 rod and all hardware for installation.

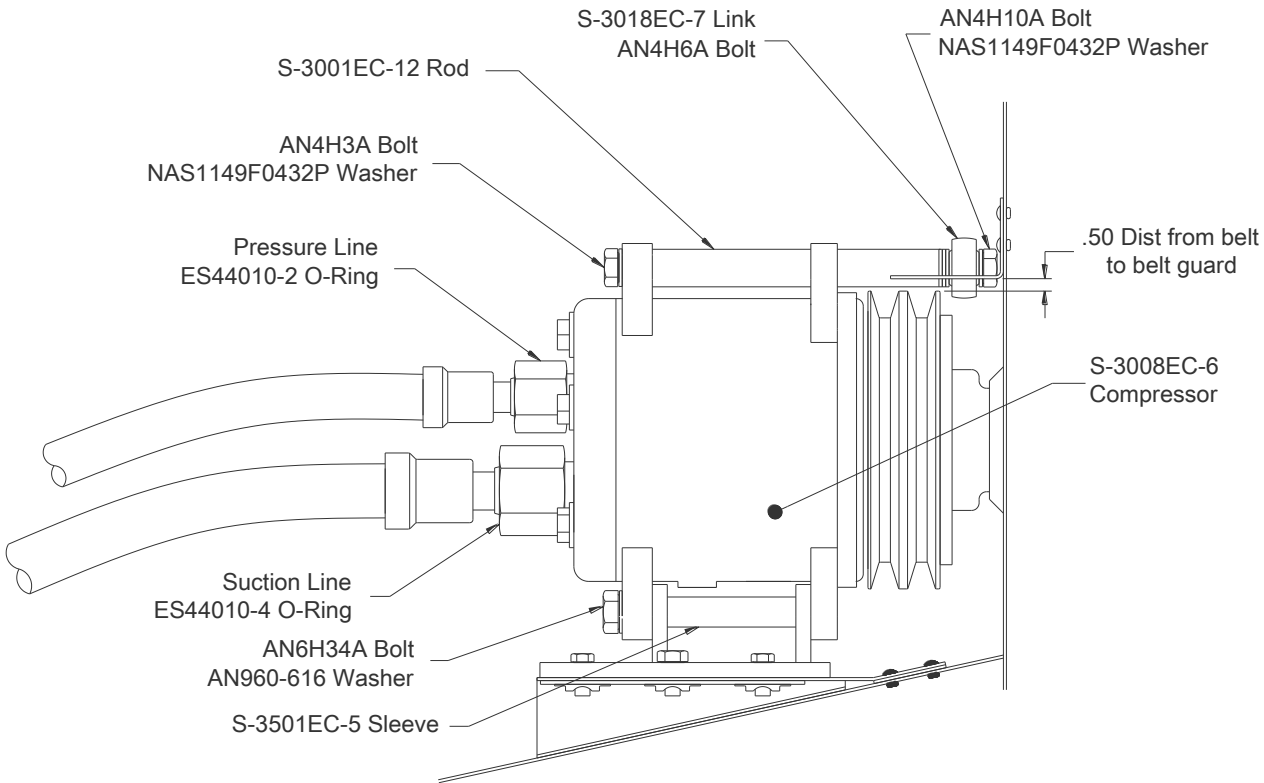

Figure 11: Compressor – View D-D

5.2 REPLACE COMPRESSOR

- a. Install S-3001EC-12 rod, AN4H3A bolt and NAS1149F0432P washer.
- b. Install belt S-3018EC-7 Link on end of S-3001EC-12 rod and safety both bolts.
- c. Install inboard bolt through S-3018EC-7 Link and collar.
- d. Replace drive belt with new belt.
- e. Adjust belt tension per Figure 2.
- f. Safety all drilled head bolts and the S-3018EC-7 Link.
- g. Replace the ES44010-2 and -4 O-Rings in hose fittings and install hoses per instructions on pg. 27.
- h. Service with R134a refrigerant per CHAPTER 6. To properly calculate the amount of oil required in the replacement compressor, it is necessary to pour the oil out of the old compressor into a clean container. Drain the oil out of the fill plug hole and then pour oil out of the suction and discharge ports while rotating the center shaft clockwise. Measure the total amount of oil removed from the old compressor. Add ½ oz. to the total measured to account for unrecoverable oil in the old compressor. This total is what is needed in the new compressor. New compressors come from Air Comm charged with 8 oz. (240 cc) of oil. This should be adjusted according to the amount of oil recovered from the old compressor and any other components being replaced. The receiver drier should always be replaced when the compressor is replaced or when the system has been open for an appreciable time, which accounts for another 1.5 oz. of oil that should be added.

Below is an example of a compressor (and receiver drier) replacement for illustration:

Evacuating the system recovers 1.5 oz. of oil. Draining the old compressor recovered 2.0 oz. of oil. Adding 0.5 oz. of residual unrecoverable oil in the compressor gives 2.5 oz. The new receiver/drier requires an additional 1.5 oz., plus 1.5 oz. lost when the refrigerant was evacuated from the system. So the total oil needed in the replacement compressor for this case is 5.5 oz. Since the new compressor comes with 8 oz. of oil, remove the oil fill plug and pour out 2.5 oz. of oil. Torque compressor oil fill cap to 132-216 in-lb.

6. REMOVE AND REPLACE COMPRESSOR DRIVE BELT (Figure 12).**6.1 REMOVE COMPRESSOR DRIVE BELT**

- a. To remove the compressor drive belt it is necessary to remove the tail rotor drive shaft segment between the engine gearbox and the air conditioner drive pulley. Disconnect tail rotor drive shaft segment per Bell Helicopter Maintenance Manual.
- b. Remove safety wire from belt S-3018EC-7 Link turnbarrel.
- c. Loosen jam nuts on both ends of turn barrel.
- d. Rotate turn barrel to loosen drive belt.
- e. Remove outboard AN4H3A bolt from S-3018EC-7 Link.
- f. Pivot compressor inboard, then remove drive belt.

6.2 REPLACE COMPRESSOR DRIVE BELT

- a. Install new drive belt over drive pulley and compressor pulley. Next, reconnect tail rotor drive shaft segment per Bell Helicopter Maintenance Manual.

- b. Ensure that all of the washers are installed correctly. Torque all coupling nuts to 150-180 In-lbs.
- c. Reinstall tension link to S-8001EC-12 rod and safety lock wire bolt.
- d. Rotate turn barrel to tighten drive belt.
- e. Proper belt tension is important to ensure a long belt service life and to avoid excessive side load on the tailrotor driveshaft bearing.
- f. For proper belt tension add a 3 lb. force at a point mid-way between both pulleys. Tension is correct when the belt deflects 0.1 inch.
- g. Tighten jam nuts against turn barrel. Safety lock wire turn barrel.

CAUTION

**RESET BELT TENSION AFTER TWO HOURS OF
OPERATION OF NEW BELT.**

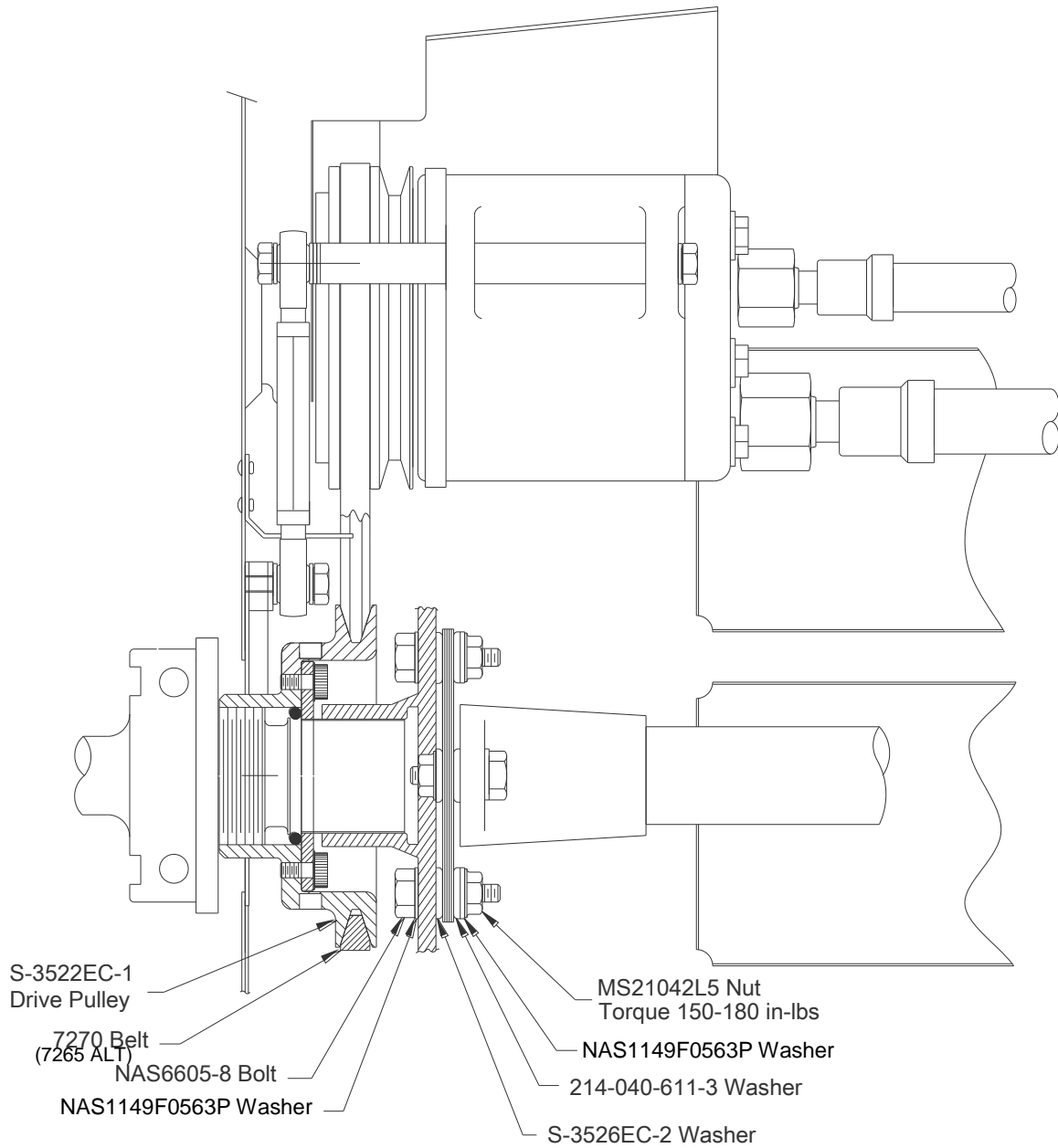
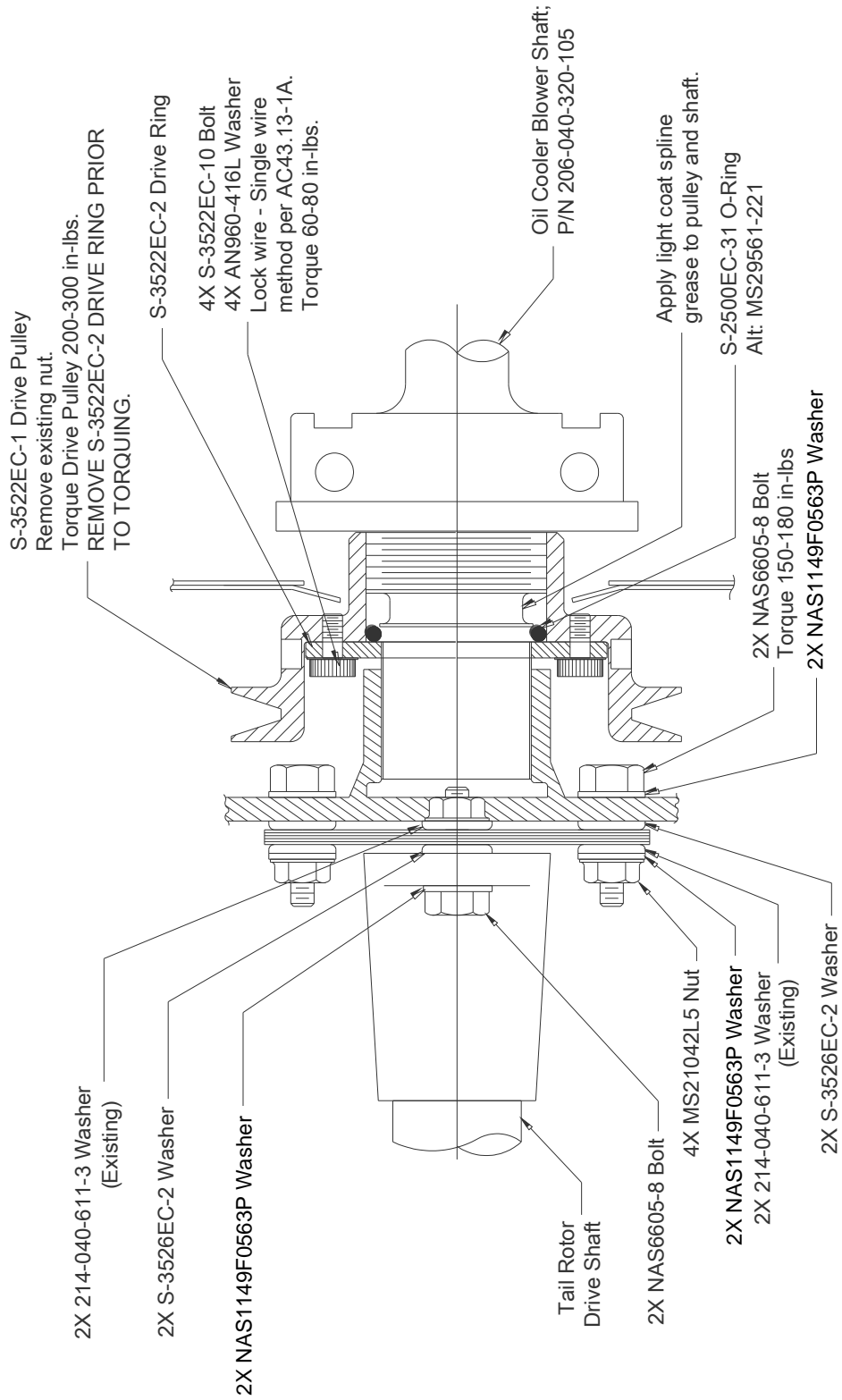

Figure 12: Compressor Drive Belt - VIEW H-H



Compressor Drive
Coupler Details

Figure 13: Compressor Drive Coupler - VIEW H-H

REMOVE AND REPLACE COMPRESSOR DRIVE PULLEY (Figure 12)

7.1 REMOVE COMPRESSOR DRIVE PULLEY

- a Remove compressor drive belt per section 6 (Above). Retain all hardware and disc. (Page 30).
- b Remove cotter pin from fwd end of S-3014EC-1 bolt assembly and remove AN320-6 nut.
- c Remove drive pulley from 206-040-320 shaft assembly.

7.2 REPLACE COMPRESSOR DRIVE PULLEY

- a Apply anti seize lubricant to inside spline of drive pulley and install on 206-040-320 shaft assembly.
- b Torque AN320-6 nut to 40-60 in/lbs and install new AN380-3-3 cotter key.
- c Re-install belt and driveshaft per section 6 (Page 30).

7. REMOVE AND REPLACE FORWARD EVAPORATOR (Figure 14)

8.1 REMOVE FORWARD EVAPORATOR

- a. Recover refrigerant using Robinair Model 34700 Recover/Recycling/Recharge Station or equivalent.
- b. Remove instrument side panel just aft of evaporator.
- c. Remove Suction and Pressure hoses from evaporator.
- d. Install caps and plugs over outlets and hoses.
- e. Disconnect electrical connector.
- f. Disconnect air outlet duct from evaporator.
- g. Remove and retain evaporator mounting hardware.
- h. Remove evaporator.

8.2 REPLACING FWD EVAPORATOR

- a. Re-install the evaporator and its mounting hardware.
- b. Reconnect air outlet duct to evaporator.
- c. Reconnect electrical connectors.
- d. Remove caps and plugs over outlets and hoses.
- e. Replace the ES44012-2 and -4 O-Rings in hose fittings and install hoses per instructions on pg. 27.
- f. Reconnect suction and pressure hoses to evaporator.
- g. Re-install instrument side panel just aft of evaporators.
- h. Service with R134a refrigerant per CHAPTER 6.

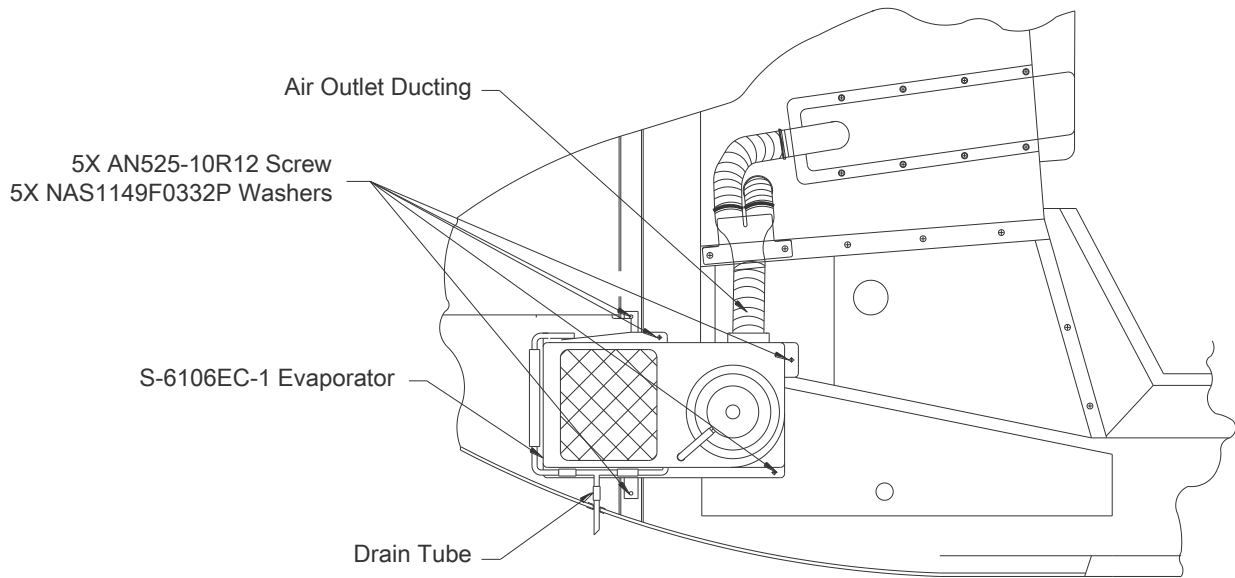

Figure 14: Forward Evaporator – View G-G

8. REMOVE AND REPLACE AFT EVAPORATOR (Figure 15)

9.1 REMOVE AFT EVAPORATOR

- a. Remove plastic Hat Rack from aft end of cabin.
- b. Open baggage door and remove oval ceiling panel.
- c. Recover refrigerant using Robinair Model 34700 Recover/Recycling/Recharge Station or equivalent.
- d. Remove Suction and Pressure hoses from evaporator.
- e. Install caps and plugs over outlets and hoses.
- f. Disconnect electrical connector.
- g. Disconnect air inlet and outlet ducts from evaporator.
- h. Remove and retain evaporator mounting hardware.
- i. Remove evaporator.

9.2 REPLACING AFT EVAPORATOR

- a. Reinstall the evaporator and mounting hardware.
- b. Reconnect air inlet and outlet ducts to evaporator.
- c. Reconnect electrical connectors.
- d. Remove caps and plugs over outlets and hoses.
- e. Reconnect suction and pressure hoses to evaporator.
- f. Replace the ES44012-2 and -4 O-Rings in hose fittings and install hoses per instructions on pg. 27.
- g. Service with R134a refrigerant per CHAPTER 6.
- h. Reinstall oval ceiling panel in baggage compartment.
- i. Reinstall plastic hat rack in aft end of cabin.

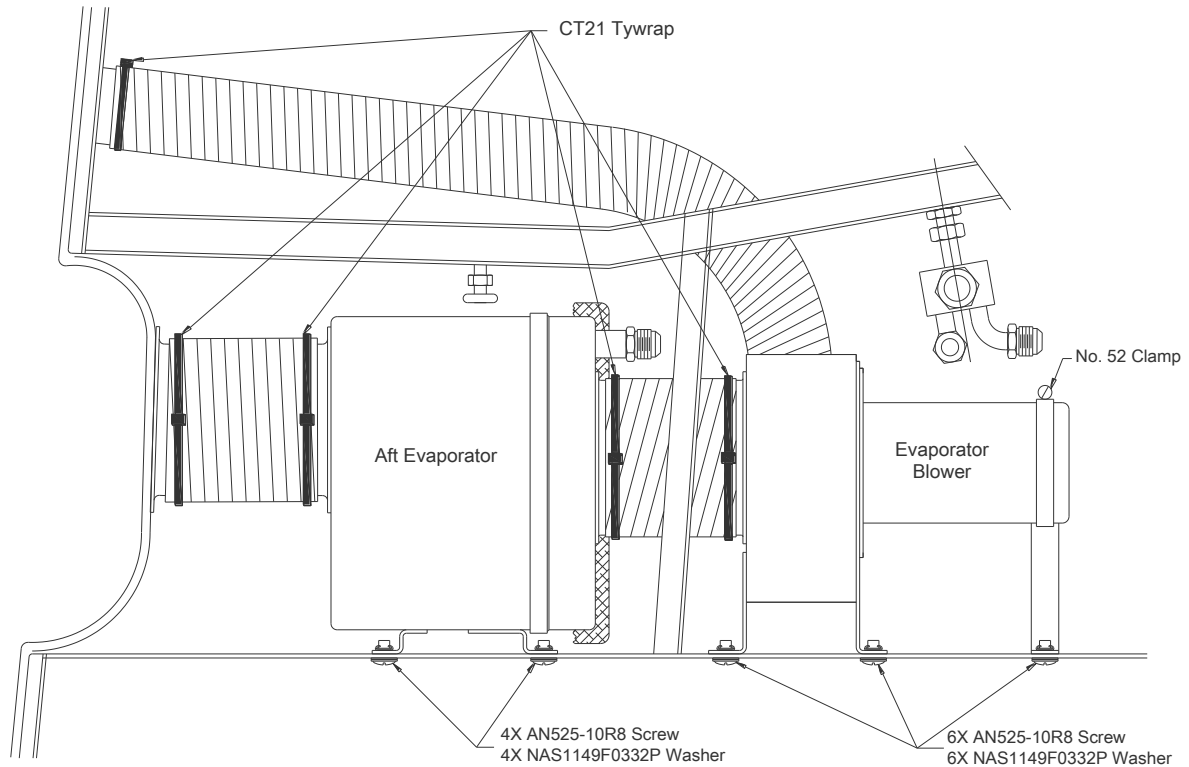

Figure 15: Evaporator Blower - VIEW E-E

9. REMOVE AND REPLACE AFT EVAPORATOR BLOWER (Figure 15)

10.1 REMOVE AFT EVAPORATOR BLOWER

- a. Open baggage door and remove oval ceiling panel.
- b. Disconnect electrical connector on blower.
- c. Remove all three flex ducts from blower housing and adapter.
- d. Remove AN525-10R8 screws that support blower.
- e. Remove blower through access panel opening in baggage compartment ceiling.

10.2 REPLACING AFT EVAPORATOR BLOWER

- a. Open baggage door and remove oval ceiling panel.
- b. Install blower through access panel opening in baggage compartment ceiling.
- c. Install all three flex ducts to blower housing and adapter using CT21 cable ties.
- d. Install 6 ea. AN525-10R8 screws that support blower.
- e. Connect electrical connector on blower.
- f. Test blower to ensure blower wheel does not rub and turns the right direction.

10. REMOVE AND REPLACE CONDENSER BLOWER ASSEMBLY (Figure 16 and Figure 17).

11.1 REMOVE CONDENSER BLOWER ASSEMBLY

- a. Deactivate Air Conditioner circuit breaker on overhead circuit breaker panel.
- b. Working under aircraft beneath baggage compartment floor, remove 13ea AN525-10R12 screws.
- c. Swing blower assembly down and disconnect Molex electrical connector.
- d. Remove 6 ea. AN525-10R8 screws MS21042L3 nuts and NAS1149F0332P washers. Remove condenser blower assembly.

11.2 REPLACING CONDENSER BLOWER ASSEMBLY

- a. Install condenser blower assembly.
- b. Install the electrical connectors. For kits prior to 2015 that use the Molex connector refer to CHAPTER 7, Section 4, page 28 for installation information.
- c. Secure condenser blower with retained hardware.
- d. Under aircraft beneath baggage compartment floor, install 13 AN525-10R12 screws.
- e. Activate air conditioner circuit breaker on overhead panel.
- f. Turn air conditioner switch to "ON". Ensure that scoop opens and blower draws air in through scoop and out through heat exchanger.

11. REMOVE AND REPLACE CONDENSER HEAT EXCHANGER (Figure 18).

12.1 REMOVE CONDENSER HEAT EXCHANGER

- a. Remove aft panel in baggage compartment.
- b. Recover refrigerant using Robinair Model 34700 Recover/Recycling/Recharge Station or equivalent.
- c. Remove Suction and Pressure hoses from condenser heat exchanger.
- d. Install caps and plugs over outlets and hoses.
- e. Remove condenser blower assembly per step 10 above.
- f. Remove heat exchanger retaining screws from under side of baggage compartment.
- g. When heat exchanger is loose, remove it through the blower assembly opening.

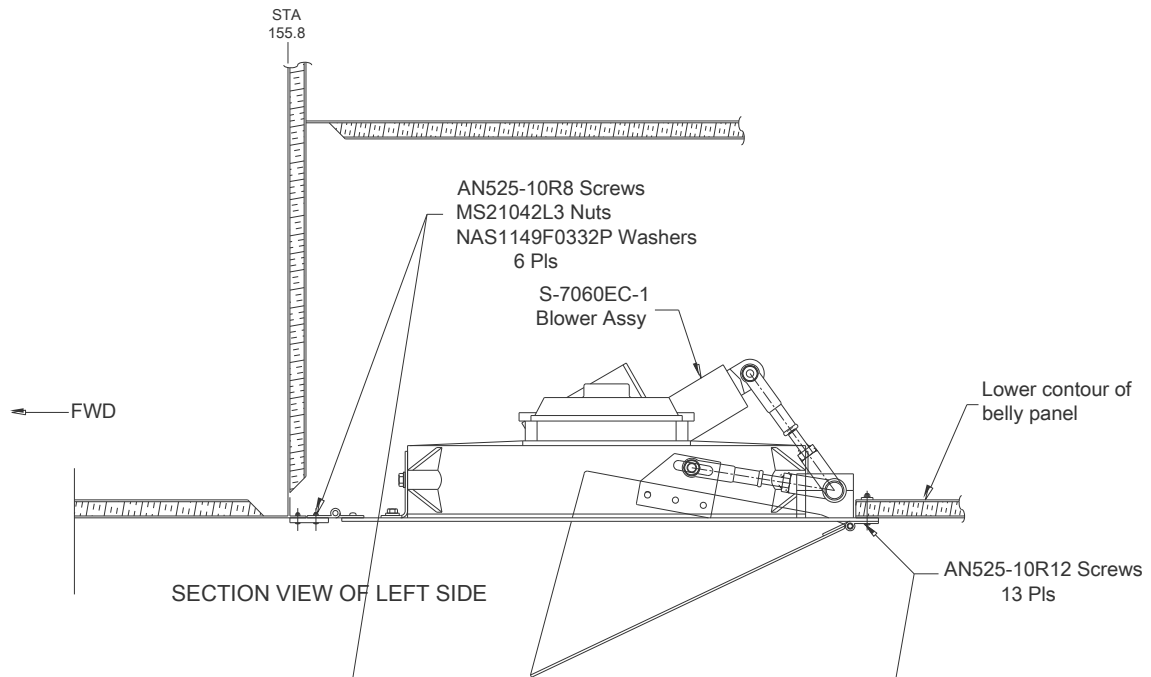

Figure 16: Condenser Install

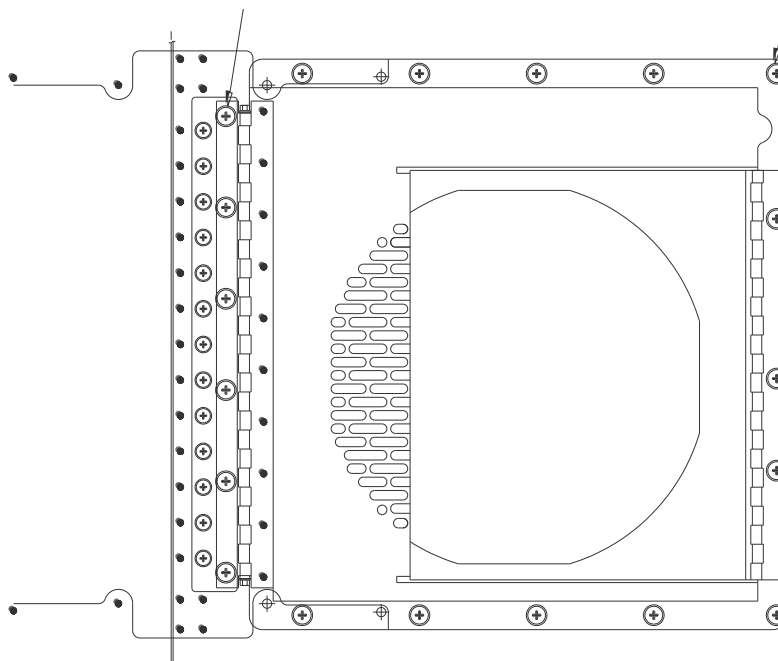

Figure 17: Condenser Install - VIEW C-C

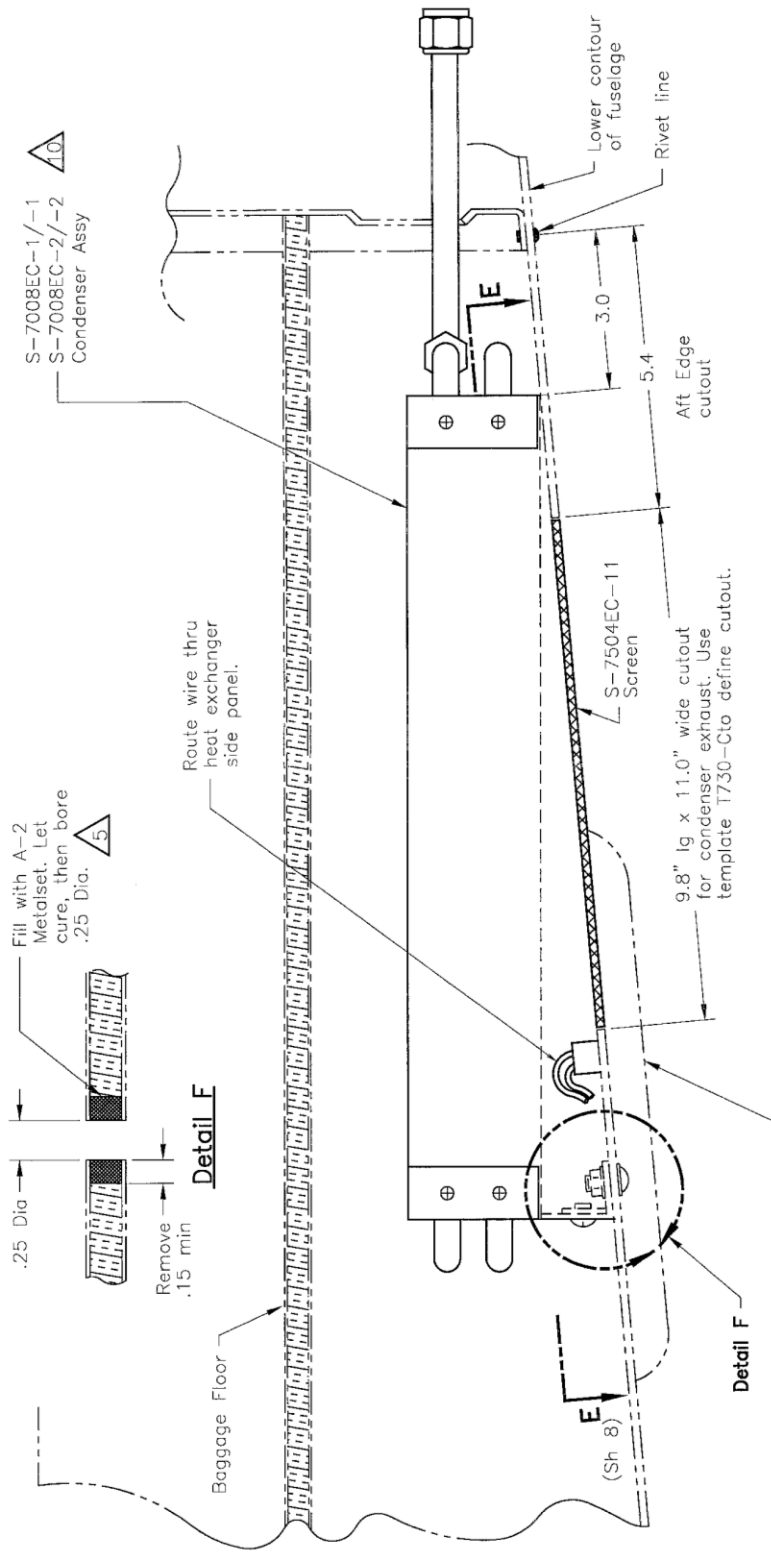

Figure 18: Condenser Install - View E-E

12.2 REPLACING CONDENSER HEAT EXCHANGER

- a. Replacing the heat exchanger is the reverse of removal.
- b. Insert heat exchanger through the blower assembly opening.
- c. Secure heat exchanger in place using original hardware.
- d. Replace the ES44012-2 and -3 O-Rings in hose fittings and install hoses per instructions. See section 11.
- e. Service with R134a refrigerant per CHAPTER 6.
- f. Reinstall condenser blower assembly per Step 10 of this section.

12. REMOVE AND REPLACE BYPASS VALVE (Figure 19).

13.1 REMOVE BYPASS VALVE

- a. Remove aft panel in baggage compartment.
- b. Recover refrigerant using Robinair Model 34700 Recover/Recycling/Recharge Station or equivalent.
- c. Remove 2X MS35275-240 Screws from valve mount bracket.
- d. Cut wires at splices.
- e. Disconnect tubing from valve and remove valve from aircraft.

13.2 REPLACE BYPASS VALVE

- a. Install valve in aircraft and connect tubing.
- b. Re-connect wires using new M81824/1-2 splices.
- c. Reinstall retained screws in valve mount bracket.
- d. Service with R134a refrigerant per CHAPTER 6.
- e. Always install new O-Rings in fittings.
- f. Always use back-up wrenches when tightening tube or hose fittings.
- g. Reinstall aft panel in baggage compartment.

13. REMOVE AND REPLACE BINARY SWITCH (Figure 19).

14.1 REMOVE BINARY SWITCH

- a. Remove aft panel in baggage compartment.
- b. Remove electrical connectors from switch.
- c. Remove switch from tube.

NOTE

Not Necessary to discharge system.

- d. Place cap over tube fitting.

14.2 REPLACE BINARY SWITCH

- a. Remove cap from tube fitting and install switch.

NOTE

Do not over tighten switch.

- b. Re-connect wires to Binary Switch.
- c. Reinstall aft panel in baggage compartment.

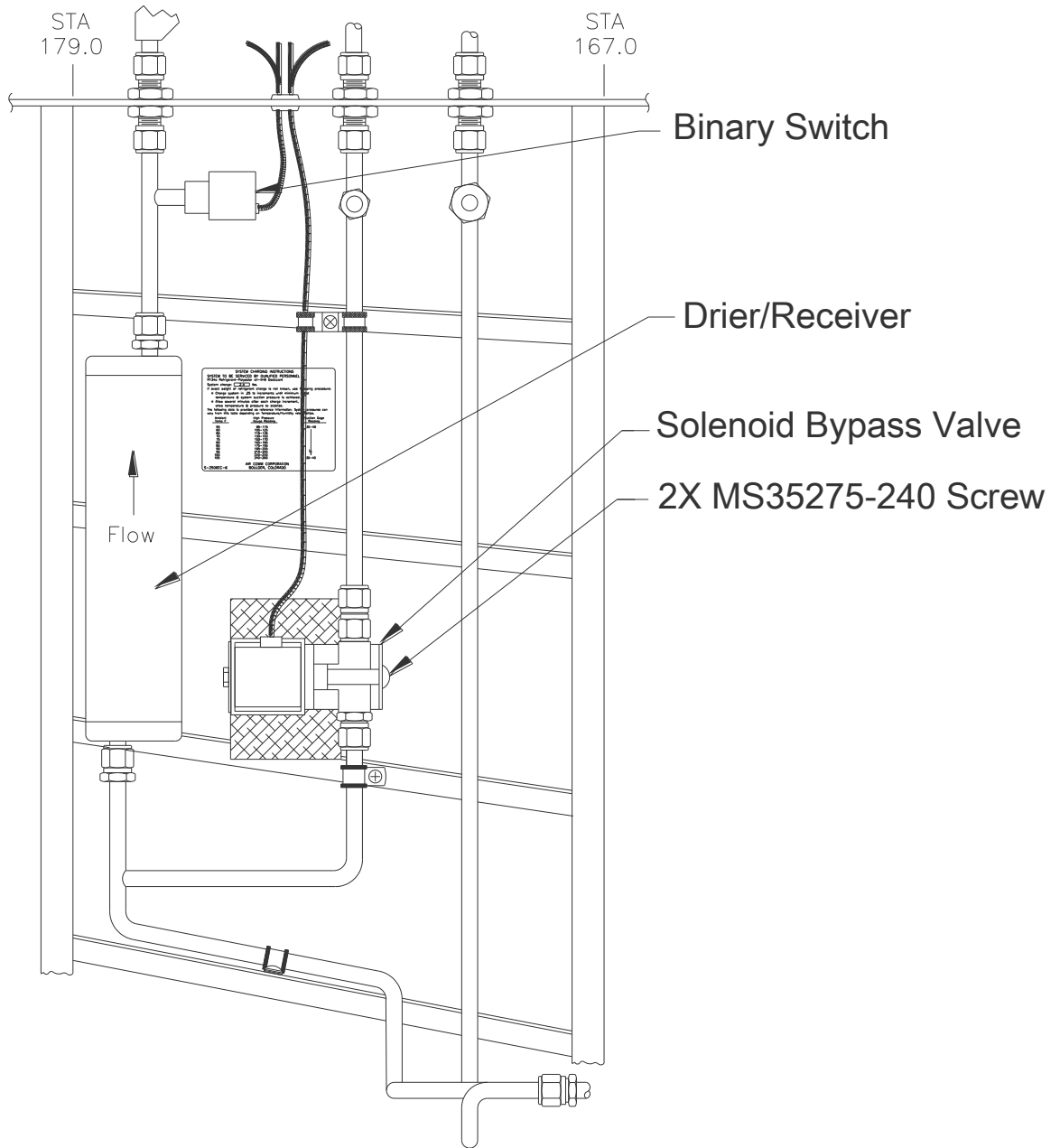

Figure 19: Binary Switch – View F-F

CHAPTER 8

TROUBLESHOOTING

1. System Troubleshooting

Prior to troubleshooting a defective system, it is advisable to conduct a visual inspection for general condition and obvious signs of damage or failure.

The following matrix lists the easiest checks and the most likely problems.

Problem	Cause	Solution
Premature Belt Failure	<ul style="list-style-type: none"> a. Belt too loose b. Compressor misalign. c. System over charged 	<ul style="list-style-type: none"> a. Adjust belt tension b. Re-install/align compressor c. Adjust system charge
Condenser blower motor Circuit Breaker "Pops"	<ul style="list-style-type: none"> a. Probable cause- Overheating of condenser blower motor 	<ul style="list-style-type: none"> a. Check for loose or rubbing of fan blade, or possible replacement of motor
Water (Condensate) in area of the aft evaporator	<ul style="list-style-type: none"> a. Condensate drain fitting on evaporator not sealed b. Evaporator housing not sealed c. Drain line / check valve not installed properly d. Condensate forming on plumbing fittings 	<ul style="list-style-type: none"> a.b.c. Verify that installation conforms to drawing requirements. (remove evaporator inlet duct, and pour 1/2 ltr. Of water into housing assy. To check for leaks & drainage. d. apply cork insulation to all exposed refrigerant lines.
Water in chin bubble area of forward evaporator	<ul style="list-style-type: none"> a. Forward evaporator housing not sealed b. Condensate drain line fittings not secure at evaporator connection. c. Drain line check valve not installed 	<ul style="list-style-type: none"> a. Same as above.
Conditioned air outlet louvers broken / loose		<ul style="list-style-type: none"> a. Replace Louvers
Evaporator Coil freeze up	<ul style="list-style-type: none"> a. System suction pressure (temperature) too low. System suction pressure should not be below 20 psi. 	<ul style="list-style-type: none"> a. Adjust system charge to obtain 25 – 32 psi.
System not Cooling	<ul style="list-style-type: none"> a. Loss of refrigerant b. Water in system 	<ul style="list-style-type: none"> a. Leak check, evacuate system and recharge. b. Evacuate system, replace receiver drier bottle, & recharge
System with Poor Cooling	<ul style="list-style-type: none"> a. By-pass Valve 	<ul style="list-style-type: none"> a. Check to ensure the temperature control knob is in the full cold position, and the temperature control circuit breaker has not tripped. If the valve remains open (by-passing refrigerant) the valve will need replacement.

2. ELECTRICAL

With the engine off turn switch to "Blower" and make sure all evaporator blowers operate in both Hi and Low modes. Pull evaporator circuit breaker in battery compartment, and turn switch to A/C. Check that the condenser blower and actuator assembly is working, and the compressor clutch is engaging.

3. SYSTEM CHARGE

See page 24 "Charging Procedures".

4. EXPANSION VALVE MALFUNCTION

If the cooling loss is limited to only one evaporator, it is most likely a defective expansion valve.

Loss of cooling in all evaporators (assuming that there were no problems identified during steps 1 or 2) could be caused by refrigerant flow blockage at the expansion valves. This blockage could be due to ice or dirt.

Replacement of the drier bottle and a thorough system evacuation might be a fix (remove the possibility of ice at the expansion valve nozzles).

5. COMPRESSOR MALFUNCTION

If the system will not maintain the pressures and there are no system leaks, the problem could be a failed compressor. The compressor must then be replaced.

6. SYSTEM LEAK CHECK

The system should be leak tested using an electronic leak detector. Initial leak check can be accomplished with a refrigerant charge of .5 lbs and the electronic leak detector. Each fitting should be checked and repaired prior to the final charging process.

Do not use compressed air for the pressure check! Compressed air can introduce moisture in the system which will cause it to operate poorly or not at all. Take your time, and check all around each fitting. A little extra time during the leak check will save a significant amount of time later during servicing or troubleshooting.

All leak checks should be conducted with the air conditioner "off". Since the refrigerant is heavier than air, leaks are most likely detected on the underside of hoses and fittings. Also the refrigerant will collect in low areas and provide an erroneous leak indication. A stream of "shop air" through a nozzle is useful in clearing an area just before checking for leaks.

If a leak is detected at an O-ring fitting, reclaim the system and install a new O-ring. Lubricate the O-ring with refrigerant oil prior to installation.

A small amount of leakage (one ounce per year) past the compressor seal is normal. Most leak detectors are sensitive enough to show a leak of this magnitude.

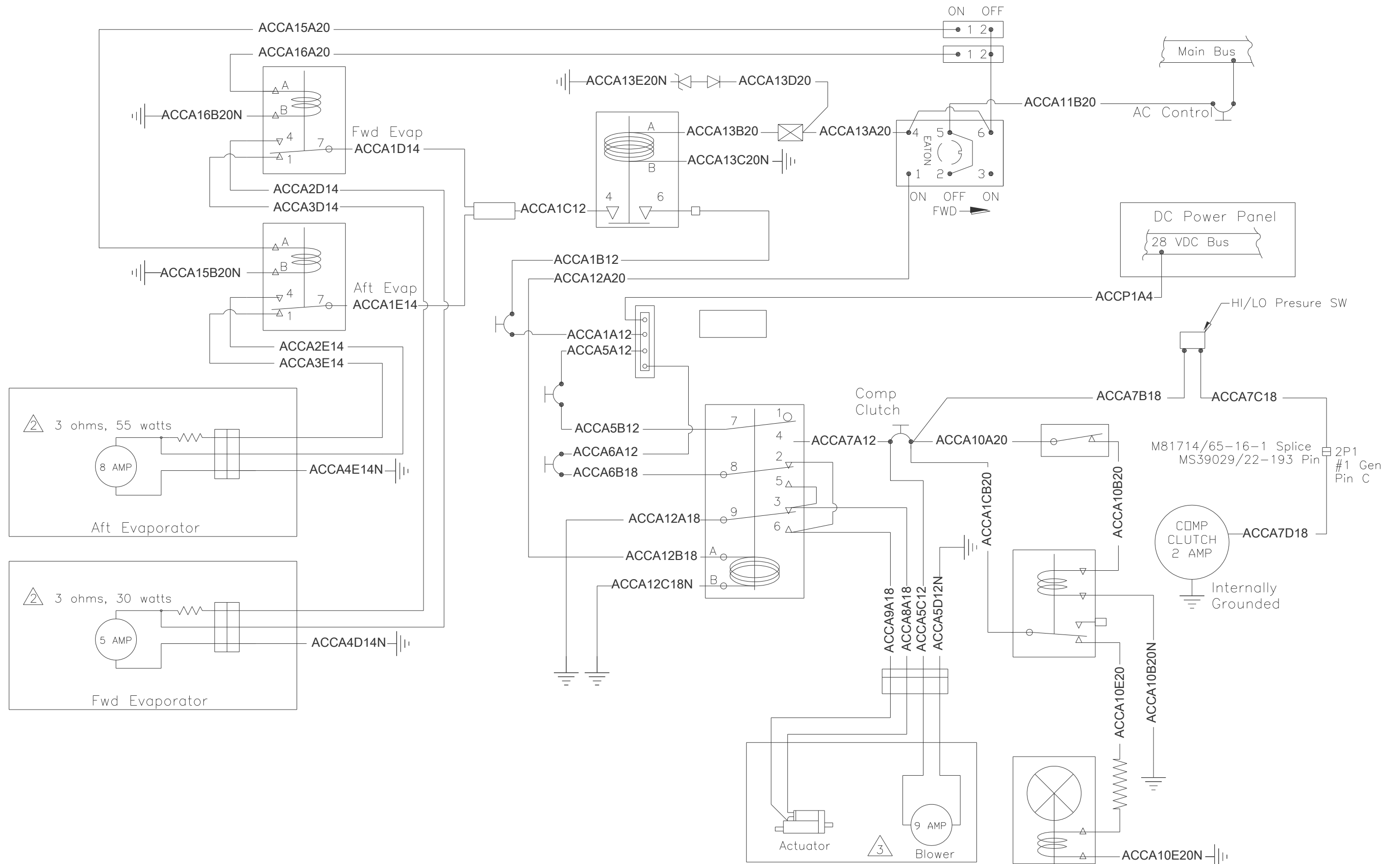

Figure 20: Electrical Schematic

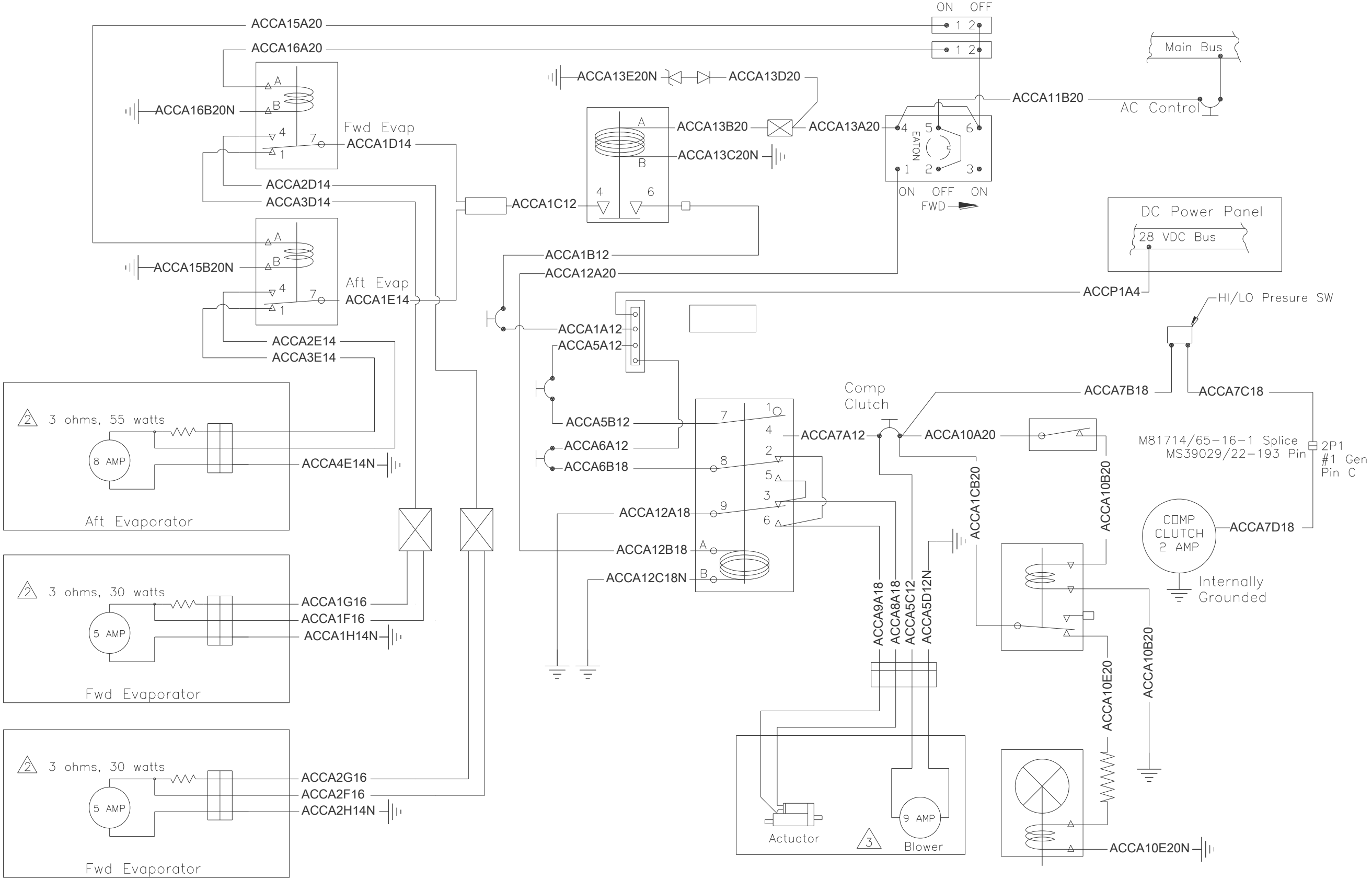

Figure 21: Electrical Schematic

APPENDIX A**WEIGHT AND BALANCE DATA**

Correct aircraft empty weight and center of gravity as indicated below:

ITEM	Wt. (lbs)	Arm (in.)	Mom. (in-lbs)
206EC-206-1 Air Conditioner (Standard – One L/H Fwd. & Aft. Evap) S-6078EC-1 Aft Evap Blower- Panasonic	84.88	150.7	12,791
206EC-206-1 Air Conditioner (Standard – One L/H Fwd. & Aft. Evap) S-6102EC-1 Aft Evap Blower- FASCO	85.63	151.0	12,930
206EC-206-2 Air Conditioner (One R/H Fwd. & Aft. Evap) S-6078EC-1 Aft Evap Blower- Panasonic	84.88	150.7	12,791
206EC-206-2 Air Conditioner (One R/H Fwd. & Aft. Evap) S-6102EC-1 Aft Evap Blower- FASCO	85.63	151.0	12,930
206EC-206-3 Air Conditioner (Dual Fwd. & Aft. Evap) S-6078EC-1 Aft Evap Blower- Panasonic	96.82	137.6	13,248
206EC-206-3 Air Conditioner (Dual Fwd. & Aft. Evap) S-6102EC-1 Aft Evap Blower- Panasonic	97.03	137.9	13,380

[S-6102EC-1 Aft evap. Blower with FASCO motor replaces S-6078EC-1 with obsolete Panasonic motor]