



12037 N Highway 99
Seminole, OK 74868
Phone (405) 382-0731
Fax (405) 382-0737
<http://www.enviro-ok.com>

OPERATING, SERVICING, AND COMPONENT

MAINTENANCE MANUAL

General Systems

R-12 Air-Conditioning Systems

1250100 SERIES

ATA SPECIFICATION

21-00-00



**General Servicing and
Maintenance
R-12**

REVISIONS

Date	Revision	Description of Change	Approved
7/15/91	-A-	ADD SECTION 13.0 COMPONENT WARRANTY CONSIDERATIONS	W.C.
8/23/95	-B-	REWRITTEN TO INCLUDE EPA SERVICING PROCEDURES	B.T
4/29/96	-C-	REVISED PARA. 7.4.2. TENSIONING LOAD WAS: 3.25 TO 3.75 LBS.	S.R.
10/22/98	-D-	REVISED PARA. 12.4 REC.-DRIER REPLACEMENT WAS: 1000 -1500 HRS OR AFTER COMP. FAILURE OR LINE RUPTURE.	S.R.
8/22/02	E	CORRECTED TABULATED SUCTION PRESSURE VALUES IN SECTION 5.3.13 WAS: 22±2 AT 60-70°F, 23±2 AT 80°F, 24±2 AT 90°, 26±2 AT 103°F	S.R.
1/24/07	F	DELETED LINE OF PARA. 12.9 PRESSURE SWITCH; WAS: CALIBRATION CHECK AT 1000 HOURS.	E.G.
4/27/07	G	Re- format document, combine Section 12.1 thru 12.10 into Table 2. Correct Caution in sec 9.4 was flush with isopropyl alcohol is flush with R-12 refrigerant.	BH
10/25/07	H	Section 8.6....was "Only approved vendor brushes are used. (Reference ESI P/N 1251171)"...is "Only approved vendor brushes are used. Contact Enviro Systems customer service to order approved brushes."	BH
10/3/08	I	Section 12 Inspection Schedule...Evaporators...removed all references to brush inspection and replacement.	BH
1/22/09	J	Fixed page numbering errors on last three pages of document.	BH
10/05/11	1	Rewrite and Updated entire manual using ATA Spec 2200 as guide. Changed number of manual to 21-00-00 was(GM R-12). Show revisions numerically Renum. Sections to Outline Format	BH

Effective: All



**General Servicing and
Maintenance
R-12**

TABLE OF CONTENTS

REVISIONS	1
TABLE OF CONTENTS	2
LIST OF TABLES	3
LIST OF FIGURES	3
1. MANUAL INTRODUCTION	4
1.1. General introduction (How to Use):	4
1.2. Acronyms, Abbreviations, and Symbols:	5
1.3. Standard Torque Values:	5
1.4. Documents Required:	5
1.5. Consumable Products:	6
2. R-12 SYSTEM DESCRIPTION AND OPERATION	7
2.1. General Description:	7
2.2. General System Operation	8
2.3. System R-12 Component Location:	8
3. TESTING AND FAULT ISOLATION	9
3.1. General:	9
3.2. Compressor Condenser Module Assembly Testing Procedures:	9
3.3. Evaporator Module Assembly Testing Procedures	9
3.4. System Leak Check Testing Procedure:	10
4. EVACUATION AND CHARGING PROCEDURE:	13
4.1. General	13
4.2. Evacuation Procedure:	14
4.3. Refrigerant Charging Procedure:	14
5. EXPANSION VALVE ADJUSTMENT/BALANCING PROCEDURE	17
5.1. General	17
5.2. Expansion Valve Adjustment:	17
5.3. Valve Balancing Procedure:	18
6. COMPRESSOR DRIVE BELT INSPECTION & MAINTENANCE	19
6.1. General:	19
6.2. Belt Removal Procedure:	19
6.3. Drive Belt Replacement Procedure:	19
6.4. Drive Belt Alignment Procedure:	20
6.5. Drive Belt Tensioning Procedure:	20
7. COMPRESSOR DRIVE MOTOR INSPECTION AND MAINTENANCE	22
7.1. Drive Motor Inspection	22
7.2. Motor Brush Inspection Procedure:	22
7.3. Commutator Wear Inspection:	24
7.4. Motor Insulation Resistance Check:	26
7.5. Internal Contamination Inspection:	26
7.6. Motor Bearing Inspection:	27
7.7. Motor Brush Replacement	27
7.8. Motor Removal:	29
7.9. Motor Replacement:	30
8. COMPRESSOR ASSY R-12 INSPECTIONS AND MAINTENANCE	31
8.1. Special Tools And Equipment Required:	31
8.2. Compressor Inspection Procedure:	31
8.3. Compressor Removal:	31
8.4. Compressor Replacement:	32
8.5. Compressor Oil Level Check:	33
9. EVAPORATOR MODULE INSPECTION AND MAINTENANCE	34

Effective: All



**General Servicing and
Maintenance
R-12**

9.1.	Evaporator Coil Inspection:	34
9.2.	Condensate Drain And Tubing Inspection:.....	34
9.3.	Cool Air Ducting Inspection:	34
9.4.	Evaporator Module Blower Motor Removal And Replacement.....	34
9.5.	Expansion Valve Removal And Replacement:.....	35
10.	TROUBLE SHOOTING THE R-12 AIRCONDITIONING SYSTEM.....	37
10.1.	Diagnosis	37
11.	COMPONENT INSPECTION, SERVICING AND/OR MAINTENANCE SCHEDULE	40
11.1.	Required Inspections, Maintenance, and Replacement.....	40
12.	SYSTEM OFF SEASON FUNCTIONAL TESTS:	41
12.1.	General:	41
12.2.	Procedures	41
13.	SYSTEM LONG TERM SHELF STORAGE	42
13.1.	Storage and Procedures Terms	42
13.2.	Internal Pressures.....	42
13.3.	Contamination Check	42
14.	COMPONENT WARRANTY CONSIDERATIONS:	43
14.1.	Warranties	43
15.	SERVICE PRECAUTIONS:	44
15.1.	Refrigerant Handling.....	44
15.2.	Recovery Of Refrigerant.....	44
15.3.	Ventilation	44
15.4.	Avoid Use Of Compressed Air.....	44

LIST OF TABLES

Table 1	Standard Torque Values	5
Table 2	Consumable Products.....	6
Figure 1	Suction and Discharge Pressure	16
Table 3	Diagnosis and Trouble Shooting.....	37
Table 3	Diagnosis and Trouble Shooting Continued	38
Table 3	Diagnosis and Trouble Shooting Continued	39
Table 4	Maintenance Schedule	40

LIST OF FIGURES

Figure 2	Belt Alignment.....	21
Figure 3.3:	Commutator Excellent Condition Example	24
Figure 3.4:	Commutator Serviceable Condition Example.....	25
Figure 3.5:	Commutator Unserviceable Condition Example.....	26
Figure 4	Air Conditioning System	45
Figure 5	Electrical Schematic	45

Effective: All



**General Servicing and
Maintenance
R-12**

1. MANUAL INTRODUCTION

1.1. General introduction (How to Use):

- 1.1.1. This operating, servicing and component maintenance manual (CMM) covers the requirements for field servicing the R-12 air conditioning system. This document includes general component information for servicing, maintenance, inspection requirements. list.
- 1.1.2. This component maintenance manual has been prepared with guidance from the Air Transport Association of America (ATA) Specification 2200. The user must not change the repair methods in this manual without authorization from the aviation authorities and the manufacturer.
- 1.1.3. This manual gives the procedures to perform the servicing and maintenance of the component in a workshop environment as well as on the aircraft. Only approved personnel with the necessary skills shall perform the maintenance procedures in this manual. Although Enviro Systems tries to cover all conceivable issues that may arise, there may be issues that are not covered in this manual. In these cases, please call Enviro Systems customer service.
- 1.1.4. You should use the instructions in this manual to do all the maintenance procedures related to the component. Read all the related warnings, cautions and notes before you begin work on the components. Warnings, cautions and notes shown in this manual provide the following information:
 - 1.1.4.1. **WARNING:** Discloses vital information in order to prevent injury or death while performing the maintenance procedure.
 - 1.1.4.2. **CAUTION:** Discloses vital information in order to prevent damage to the equipment during the maintenance procedure.
 - 1.1.4.3. **NOTE:** Discloses more information that will help perform a step of the procedure or refers to a different procedure.



**General Servicing and
Maintenance
R-12**

1.2. Acronyms, Abbreviations, and Symbols:

- CMM Component Maintenance Manual
- ATA Air Transport Association
- BTUH British Thermal Unit per Hour (standard in U.S. heating and air-conditioning)
- Db Dry Bulb
- RH Relative Humidity
- CFM Cubic Feet per Minute
- In.w.g Inch of Water Gage
- VCS Vapor Cycle System
- MSDS Material Safety Data Sheet
- PSIG Pressure Per Square Inch, Gage
- SAE Society of Automotive Engineers
- CCW Counter Clockwise
- CW Clockwise
- OAT Outside Air Temperature

1.3. Standard Torque Values:

TYPE FASTENER	DESCRIPTION/LOCATION	TORQUE
.25-28 SET SCREW	ALL LOCATIONS	40-50 IN-LBS
6-32 SCREW	ALL LOCATIONS	8-10 IN-LBS
8-32 SCREW	ALL LOCATIONS	12-15 IN-LBS
10-32 SCREW	ALL LOCATIONS	20-25 IN-LBS
¼-28-UNF	ALL LOCATIONS	50-70 IN-LBS
5/16-24UNF	ALL LOCATIONS	100-140 IN-LBS
3/8-24UNF	ALL LOCATIONS	160-190 IN-LBS
3/8 PLUMBING CONNECTIONS	RECEIVER DRYER INLET PORT	130-160 IN-LBS
½ PLUMBING CONNECTIONS	COMPRESSOR DISCHARGE PORT	300-400 IN-LBS
½ PLUMBING CONNECTIONS	COIL HEADERS	250-325 IN LBS

Table 1 Standard Torque Values

1.4. Documents Required:

- Airframe maintenance manual)



**General Servicing and
Maintenance
R-12**

1.5. Consumable Products:

PART NUMBER	DESCRIPTION	REMARKS
11602	SEALANT RTV	BLACK
7471	THREAD SEALANT PRIMER	LOCTITE
569	THREAD SEALANT	LOCTITE
BVM100N	MINERAL REFRIGERANT OIL	BVA OILS

Table 2 Consumable Products



**General Servicing and
Maintenance
R-12**

2. R-12 SYSTEM DESCRIPTION AND OPERATION

2.1. General Description:

- 2.1.1.** The air conditioning system installed on the aircraft is not considered a primary flight system. However, an air conditioning system does perform the important function of providing passenger and flight crew comfort during aircraft movement on the ground and while in flight. Aircraft air conditioning systems not only provide effective passenger cooling, but must also maintain a high level of reliability to minimize aircraft downtime due to unscheduled repairs.
- 2.1.2.** In order to ensure component reliability and achieve a long service life for which the system is designed, periodic inspection and preventive maintenance must be performed. Failure to complete periodic inspections, service, or maintenance schedules may reduce product life and potentially void manufacturer's warranty.
- 2.1.3.** Inspections, servicing, and/or maintenance schedules are presented in the following sections. This will ensure component and/or system reliability and performance are maintained when performed at the specified intervals.

WARNING: SERVICE TECHNICIANS ARE ADVISED TO OBSERVE STANDARD SAFETY PRECAUTIONS, SUCH AS WEARING PERSONAL SAFETY GEAR, TO PREVENT INJURY WHILE PERFORMING SERVICE TO THE UNIT. LIQUID REFRIGERANT CAN CAUSE FROSTBITE AND/OR BLINDNESS.

WARNING: PROPER VENTILATION IS REQUIRED. KEEP REFRIGERANTS AND OILS AWAY FROM OPEN FLAMES. REFRIGERANTS CAN PRODUCE POISONOUS GASSES IN THE PRESENCE OF A FLAME. WORK IN A WELL VENTILATED AREA AND AVOID BREATHING REFRIGERANT /LUBRICANT VAPOR MIST IF ACCIDENTAL DISCHARGE OCCURS.

WARNING: AVOID USE OF COMPRESSED AIR. DO NOT INTRODUCE COMPRESSED AIR OR OXYGEN INTO AN AIR CONDITIONING SYSTEM OR REFRIGERANT CONTAINER. R-12 IN THE PRESENCE OF AIR OR OXYGEN ABOVE ATMOSPHERIC PRESSURE MAY FORM A COMBUSTIBLE MIXTURE.

- 2.1.4.** Do not discharge R-12 refrigerant into the atmosphere. Although its ozone depletion potential is zero, it can have an effect on global warming. In the United States recovery and recycling are mandated by the Clean Air Act
- 2.1.5.** Refrigerant recovery/recycling service equipment must be approved for use with R-12 refrigerant. Recycling machines must be approved by Underwriters Laboratories (UL) and meet SAE standard J2210 and SAE standard J2099 for refrigerant purity.

2.2. General System Operation

- 2.2.1.** The type of cooling system installed in an aircraft operates on a closed vapor cycle concept using refrigerant R-12 as the heat absorption media. The Airborne R-12 Air Conditioning System cools the aircraft in the same manner as a cooling system in an automobile or home. However, one major difference in two type systems is the Airborne R-12 System contains components which are designed to be light weight, compact, provide high performance and operate at extreme altitudes and ambient temperatures. The Airborne R-12 Vapor Cycle cooling system provides the highest performance per aircraft horsepower than any other present cooling concept.
- 2.2.2.** The concept of air-conditioning a room, cabin or cockpit is actually very simple. A typical system is shown in Figures 4, refrigerant and Figure 5, the electrical schematic. The refrigerant is the media which absorbs and rejects the room or cabin heat. By continuous recirculation of the cabin the warm cabin air is absorbed in the evaporator module (s) and the heat is rejected to the outside through the system condenser. When the system is turned on the electric motor drives an R-12 compressor at a constant speed and capacity which compresses the R-12 refrigerant gas to a high pressure. The hot, high pressure gas then passes through the condenser coil where it is cooled and condensed into a warm liquid at constant pressure. The warm liquid is then routed into a receiver-dryer container in which the liquid and any remaining gasses are separated and any moisture in the liquid is absorbed. The warm, dry, high quality liquid is then directed to the evaporator module expansion valve where the high pressure liquid is expanded to a low pressure. The expansion process creates a super cool gas which passes through the evaporator coil and absorbs heat from the warm cabin air passing over the coils. The low pressure warm gas enters the R-12 compressor where the process starts again. In addition to cooling the air in the cabin, a refrigerant type system also removes a large percentage of the moisture, dust and pollen particles in the air. Thus, the system conditions the air as well as cooling it.

2.3. System R-12 Component Location:

- 2.3.1.** An Airborne R-12 Air Conditioning System may consist of one or more compressor-condenser and evaporator modules. Location of these components will depend on system effectiveness, available space and aircraft center of gravity restrictions.
- 2.3.2.** The Compressor Condenser Module Assembly is packaged to meet the aircraft installation requirements and contains the following major components.
- Compressor Drive Motor
 - Compressor Assembly
 - Condenser Coil
 - Receiver Dryer Assembly
 - Binary Pressure Switch

3. TESTING AND FAULT ISOLATION

3.1. General:

- 3.1.1.** Testing and Fault Isolation of the R-12 Air Conditioning System may be necessary if the system does not operate and/or perform in accordance with information contained herein. Therefore it is necessary for the service personnel to diagnose the discrepancy by troubleshooting the system and its components. To assist in this diagnoses, refer to table 3 (Trouble Shooting List)

3.2. Compressor Condenser Module Assembly Testing Procedures:

- 3.2.1.** Ensure that power is applied to the aircraft and that the air conditioning system is switched on using the cockpit mounted selector switch. Gain access to the Compressor Condenser Module (refer to the aircraft maintenance manual for removal of access panels and other hardware that might need to be removed). Verify that these components are operating and perform the following:
- Verify that system is running smoothly and that there is no excessive noise and/or vibration coming from the assembly.
 - Verify that the system is cooling properly.
- 3.2.2.** If there is excessive noise and/or vibration coming from the Compressor Condenser Module assembly or the system is not cooling, refer to the Disassembly procedures in section 5 and Check (inspection) procedures in section 7. This will help in identifying whether one or more components are dirty or damaged and are in need of repair or replacement.

3.3. Evaporator Module Assembly Testing Procedures

- 3.3.1.** Verify blower motor operation in both low and high speed positions using cockpit mounted selector switch.
- 3.3.2.** While blower motor is operating in both positions, listen carefully for the following:
- Verify that there is a distinct and noticeable change in sound of blower motor when changing from low to high speed positions. This indicates that the cockpit selector switch is functioning properly and that the blower motor is responding accordingly.
 - Verify that there is a smooth transition when changing from low to high speed positions, and that there is no excessive noise or vibration coming from the blower motor during the change. Excessive noise could indicate that the blower wheel is rubbing against the blower scroll.
- 3.3.3.** If there is excessive noise and/or vibration coming from blower motor/wheel assembly during this test, please refer to the disassembly procedures in section 5 and inspection procedures in section 7. This will help in identifying whether the blower motor wheel is dirty or damaged and is need of repair or replacement, the blower scroll is dirty or damaged and is need of repair or replacement, or the blower motor itself is in need of replacement.
- 3.3.4.** Verify that the system is cooling properly. If not, the expansion valve(s) might need aligning. Refer to Special Procedures, Section 5, for Expansion Valve Alignment procedures.



**General Servicing and
Maintenance
R-12**

3.4. System Leak Check Testing Procedure:

- 3.4.1.** A leak check of the refrigerant plumbing system is important to ensure the system maintains its charge to provide the designed performance and reduce damage to system components. A periodic check of the system charge is required to determine if any loss of refrigerant has occurred.
- 3.4.2.** A system leak check is required any time one or more of the following conditions occur:
- New system plumbing installation
 - Component replacement in the plumbing system
 - Line or hose rupture
- 3.4.3.** Special Tools and/or Equipment Required:
- Gaseous dry nitrogen, regulated source (0-500 psig)
 - R-12 refrigerant charging manifold with gauges and hoses
 - Leak check fluid (soap solution)
 - Assorted hand tools
 - Hand and eye protection
 - Hose adapter (1/2 in. male acme to 1/4 in. female flare)
- 3.4.4.** Procedure

WARNING

DURING THIS PROCEDURE PROTECTIVE EYEWEAR AND GLOVES SHOULD BE WORN TO PREVENT OPERATOR INJURY.

- 3.4.4.1.** Remove, if required, all panels, doors, shrouds, etc. to gain access to system/component being leak checked (refer to aircraft maintenance manual).
- 3.4.4.2.** Remove, if required, any enclosures or access doors to expose all tubing, hoses, fittings, etc. to the system components.
- 3.4.4.3.** Verify all plumbing connections are tight.
- 3.4.4.4.** Verify that power is removed from aircraft. If it is not practical to remove aircraft power, technician must pull and collar applicable circuit breakers.

CAUTION: HIGH PRESSURE HOSE (RED) IS CONNECTED TO PORT MARKED "D" AND THE LOW PRESSURE HOSE (BLUE) IS CONNECTED TO THE SERVICE PORT MARKED "S". INCORRECT CONNECTION COULD RESULT IN MANIFOLD DAMAGE AND/OR INCORRECT PRESSURE READINGS.

- 3.4.4.5.** Remove service port caps from the A/C system. The high pressure service port is located on the receiver-dryer and low pressure service port is located on the compressor suction header.
- 3.4.4.6.** Close all manifold gauge valves and verify hose connections are tight.



**General Servicing and
Maintenance
R-12**

- 3.4.4.7. Connect R-12 refrigerant charging manifold. R-12 service gauges contain quick-connect fittings to minimize refrigerant loss. To install quick-connect, push on firmly until locked (a "clicking" sound is heard). Hold the grip ring and pull to remove quick-connect fittings.
- 3.4.4.8. Connect yellow charging hose to a regulated dry nitrogen source

NOTE: An adapter is required to connect yellow charging hose to the nitrogen source.

CAUTION: DO NOT EXCEED 150 PSIG NITROGEN PRESSURE DURING PROCEDURE OR DAMAGE TO EXPANSION VALVE WILL RESULT.

- 3.4.4.9. Regulate nitrogen source to a pressure of 150 PSIG maximum.
- 3.4.4.10. Slowly open high pressure (red) manifold valve and allow system pressure to increase gradually until a pressure of 150psig is achieved. Allow time for system pressure to equalize across expansion valve and note final system pressure.

CAUTION: DO NOT USE ANY LEAK DYE IN R-12 SYSTEM OR DAMAGE TO SYSTEM MAY RESULT.

CAUTION: DO NOT OVER TIGHTEN PLUMBING CONNECTIONS. STRIPPED THREADS OR CRACKED FLARES MAY RESULT.

- 3.4.4.11. Apply soapy leak check fluid to each fitting connection. If leaks are detected, attempt to tighten fitting without over tightening. If leak cannot be corrected with tightening, system must be evacuated (refer to Servicing, Section 4) and then fitting must be disconnected and new thread sealant applied.
- 3.4.4.12. Using a wire brush and cleaning solvent, completely remove old thread sealant. Apply a thin layer of thread sealant primer to fitting threads.

CAUTION: WHEN APPLYING THREAD SEALANT, TAKE EXTREME CARE TO KEEP SEALANT OFF FIRST 2 OR 3 THREADS.

- 3.4.4.13. Apply Loctite thread sealant on all male fitting threads sparingly.

CAUTION: WHEN APPLYING REFRIGERANT OIL TO FLARE AND O-RING, TAKE EXTREME CARE TO KEEP OIL AWAY FROM FITTING THREADS

- 3.4.4.14. Apply a light coating of refrigerant oil to flare and/or o-ring to prevent metal galling or o-ring damage.
- 3.4.4.15. Tighten joints as required to stop leaks (refer to Table 1, Section 1 for torque values).

CAUTION: VENT SYSTEM PRESSURE VERY SLOWLY TO ASSURE COMPRESSOR OIL IS NOT VENTED WITH THE NITROGEN. DO NOT LET AIR ENTER THE SYSTEM.

- 3.4.4.16. After leak check is finished and system integrity is sound, turn off nitrogen source, disconnect yellow charging hose from nitrogen source and slowly release nitrogen pressure to zero

EFFECTIVITY: ALL



**General Servicing and
Maintenance
R-12**

3.4.4.17. Close manifold valve.

3.4.4.18. System is now ready for charging (refer to, Section 4.3).



**General Servicing and
Maintenance
R-12**

4. EVACUATION AND CHARGING PROCEDURE:

4.1. General

- 4.1.1.** Charging the refrigerant R-12 system is required on new system installations, after an accidental line break, component failure, and excessive leaks. Due to the chemical nature of the refrigerant, every precaution must be taken to protect the service person from accidental exposure to the refrigerant. See service precautions in section 14.0. Only R-12 refrigerant must be used or damage to the system will result. Overcharging the system with refrigerant and/or oil will also result in system damage or reduction in performance and service life.

WARNING: SERVICE TECHNICIANS ARE ADVISED TO OBSERVE STANDARD SAFETY PRECAUTIONS, SUCH AS WEARING PERSONAL SAFETY GEAR, TO PREVENT INJURY WHILE PERFORMING SERVICE TO THE UNIT.

CAUTION: SERVICE TECHNICIANS MUST PREVENT CONTAMINATION OF INTERNAL SYSTEM PLUMBING DURING ANY SERVICING AND/OR MAINTENANCE OPERATION. THIS INCLUDES NOT ALLOWING THE RECEIVER DRYER TO BE EXPOSED TO ATMOSPHERIC CONDITIONS FOR ANY LENGTH OF TIME. ALL PLUMBING LINES SHOULD REMAIN CAPPED WHENEVER POSSIBLE DURING THE SERVICING OF THE SYSTEM.

WARNING: DUE TO THE EVER INCREASING NUMBER OF ALTERNATE REFRIGERANTS BEING INTRODUCED ON THE MARKET, EXTREME CARE MUST BE TAKEN TO PREVENT THEIR USE IN THIS SYSTEM. ONLY R-12 REFRIGERANT IS APPROVED FOR USE IN THIS AIR CONDITIONING SYSTEM. ANY OTHER REFRIGERANT COULD CREATE A HAZARD TO BOTH THE AIRCRAFT AND SERVICE PERSONNEL.

4.1.2. Tools, fixtures, equipment, or consumable items required:

- Small hand tools and socket set
- Vacuum pump, air or electric (0-30 in.h.g.)
- Refrigerant, R-12
- R-12 charging manifold with gauges and hoses
- Thermometer, 0-150° F
- Adjustable inspection mirror
- Service light or flash light
- Shop towels
- BVM100N refrigerant oil
- External or aircraft power source, 200 AMPS.
- Reclaim/ Recycle Cart (R-12)



**General Servicing and
Maintenance
R-12**

4.2. Evacuation Procedure:

Note: Prior to charging the system with refrigerant the system must be evacuated for a minimum of 45 minutes to remove all air and moisture which can cause the system to perform incorrectly.

- 4.2.1. Verify power to system is off.
- 4.2.2. If required, perform leak check procedure described in section 4.0.
- 4.2.3. Connect charging manifold to service ports (ref. section 4.2.1 through 4.2.3).
- 4.2.4. Connect manifold (yellow) hose to the vacuum pump and turn pump on. An adapter may be required to allow vacuum pump hookup.
- 4.2.5. Open both valves on charging hose quick connect fittings to depress core if so equipped.
- 4.2.6. Open both valves on charging manifold and observe gauges.

NOTE: Low pressure gauge "blue" will indicate vacuum value on lower range of gauge.

- 4.2.7. Evacuate system for 30 minutes. System vacuum should obtain 25-27 in. hg in 10 to 15 minutes.
- 4.2.8. Allow pump to hold a hard vacuum (29 to 30 in. hg.) for 15 minutes.
- 4.2.9. Close manifold valves and shutoff vacuum pump. Vacuum in system must not change after 5 minutes.

CAUTION: ANY CHANGE IN VACUUM PRESSURE OR FAILURE TO ACHIEVE A SYSTEM PRESSURE OF 29 INCHES HG VACUUM INDICATES THE PRESENCE OF A PLUMBING LEAK. REPEAT LEAK CHECK PROCEDURE AND LOCATE AND FIX ALL LEAKS.

- 4.2.10. Disconnect manifold service (yellow) hose. System is ready for refrigerant charging.

CAUTION: EXCESSIVE WATER OR AIR IN THE SYSTEM WILL CAUSE PRESSURE TO RISE, AND THE EXPANSION VALVE TO FREEZE-UP.

4.3. Refrigerant Charging Procedure:

Charging the system with refrigerant is required on a new system installation or when "topping off" an existing system. There are various methods of charging refrigerant into the air conditioning system. These include using refrigerant recovery/recycle units, using a charging cylinder, and direct charging using a scale. Refer to the manufacturers' instruction manual for recovery unit handling and operation.

WARNING: EYE AND HAND PROTECTION MUST BE WORN DURING THIS PROCEDURE.

- 4.3.1. Verify that all electrical power is off to system.
- 4.3.2. If required, repeat the leak check and evacuation procedures.
- 4.3.3. Connect yellow manifold charging hose to R-12 cylinder shutoff valve and open.



**General Servicing and
Maintenance
R-12**

- 4.3.4. Crack hose fitting at manifold and purge hose. If system refrigerant charge is to be recorded place refrigerant container on a 0-50 lb. scale and note the initial weight.
- 4.3.5. Open both manifold valves and allow refrigerant gas to enter system. Continue adding refrigerant until system internal pressure has stabilized.
- 4.3.6. Close manifold valves and verify system internal pressure is 50 PSIG or greater.

NOTE: If internal pressure is not 50 psig or above the low pressure cutout switch will not close and the drive motor power contactor will not operate. To assure an internal pressure of 50 psig the R-12 charging can or container must be heated to obtain a minimum charge pressure of 70-80 psig.

WARNING: DO NOT HEAT R-12 CAN OR CONTAINER WITH OPEN FLAME OR CONTAINER DAMAGE MAY RESULT WITH POSSIBLE INJURY TO OPERATOR. HEAT THE CONTAINER WITH WARM WATER OR ROOM TEMPERATURE.

- 4.3.7. Verify system electrical power is off and connect an external, 28 VDC, 200 amp power source to the aircraft.

CAUTION: DO NOT OPERATE SYSTEM WITH THE HIGH PRESSURE VALVE OPEN ON THE CHARGING MANIFOLD GAUGE SET.

- 4.3.8. Turn aircraft power on, set evaporator blower speed to high position and turn the mode switch to air-conditioning position.
- 4.3.9. With system operating, observe the system discharge and suction pressure values and refrigerant condition in the receiver-dryer sight glass.

NOTE: A flashlight and inspection mirror is required during the system charging procedure. Excessive bubbles in the sight-glass indicate a low refrigerant level.

- 4.3.10. With the R-12 cylinder connected to the charging hose, charging container shutoff valve open and with hose purged, slowly open the suction (blue) manifold valve. The suction pressure will increase to 60-70 psig while the R-12 refrigerant enters the compressor.

NOTE: As refrigerant enters the compressor a slight increase in discharge pressure will be noted (2-5 psig). Also, compressor speed will reduce slightly.

- 4.3.11. Continue to add refrigerant per the above procedure until the sight-glass is clear of excessive bubbles when charged on a hot day (95-105°F)

NOTE: A desired sight-glass liquid condition is when only occasional bubbles are observed when charging on a hot day (95-105°F.).

- 4.3.12. Close suction manifold valve (blue) and let system operate for 5-10 minutes and then check sight-glass. If sight-glass is not totally clear, open suction manifold valve and add a small quantity of refrigerant until 98% of bubbles disappear. Close manifold valve and let system stabilize.

NOTE: Letting the system stabilize is required since the expansion valve is trying to stabilize to the preset suction pressure value.



General Servicing and
Maintenance
R-12

CAUTION: DO NOT OVERCHARGE SYSTEM OR COMPONENT OR SYSTEM DAMAGE MAY OCCUR.

4.3.13. With the system fully charged and operating, observe the suction and discharge pressures. Typical values at various ambient temperatures, with hot cabins, are shown below:

OUTSIDE AMBIENT TEMPERATURE (°F)	SUCTION PRESSURE (PSIG)	DISCHARGE PRESSURE (PSIG)
60-70	28±1	145-150
80	30±1	195±10
95	34±2	215±10
103	37±2	230±10

Figure 1 Suction and Discharge Pressure

NOTE: Whenever possible charge the system on a hot day (90-100 °F). If not "topping off" may be required for hot ambient temperatures.

4.3.14. Allow system to operate for 10 minutes and then shutdown.

NOTE: After shutdown both suction and discharge pressures will immediately start equalizing. Pressures should be equal in 60 to 90 seconds for those systems containing expansion valves with bleeds.

WARNING: HAND AND EYE PROTECTION MUST BE WORN DURING THIS OPERATION TO PREVENT SUBCOOLED REFRIGERANT FROM BURNING THE EYES OR HANDS.

4.3.15. Close refrigerant container shutoff valve (turn cw). Record the refrigerant container final weight and calculate system refrigerant charge as follows: Charge (lb.) + W initial (lb.) - W final (lb.)

4.3.16. Turn knob on suction and discharge charging hose quick coupler to closed position and disconnect hoses from service ports.

4.3.17. Remove yellow charging hose from refrigerant container and store manifold gauge set.



**General Servicing and
Maintenance
R-12**

5. EXPANSION VALVE ADJUSTMENT/BALANCING PROCEDURE

5.1. General

5.1.1. Even though the automatic expansion valve is set at the factory there may be times when it must be adjusted to assure proper refrigerant flow at the desired evaporating temperature, due to excessive pressure drop for long suction line runs. Any adjustment must not affect desired suction and discharge pressures as outlined in Section 4.3.13.

5.1.2. Special tools and/or equipment required:

- External aircraft power source, 28 vdc, 200 amps.
- Inspection mirror, adjustable
- Thermometer, 0-150°F
- Flashlight or service lamp
- R-12 service manifold and gauge set

5.2. Expansion Valve Adjustment:

5.2.1. The expansion valve adjustment shall be performed in accordance with, but not limited to, the following:

5.2.1.1. Verify that system leak check and refrigerant charging has been performed and system is operating at typical values as outlined in paragraph 5.3.13.

5.2.1.2. Remove all shrouds, covers or closures which prevent access to the evaporator expansion valve adjust knob.

5.2.1.3. Remove expansion valve protective cap.

5.2.1.4. Verify that inlet to evaporator coil and blower ducting are free of any contamination or restrictions which could alter air flow.

5.2.1.5. Verify blower speed switch in high position.

5.2.1.6. Verify R-12 manifold gauges and hoses connected to compressor service valves and to the system are operating normally.

5.2.1.7. Close cabin and cargo doors and allow system to operate for 5 minutes.

5.2.1.8. Record compressor suction and discharge pressures and evaporator air inlet and outlet temperatures.

NOTE: Typical temperature difference of evaporator inlet and outlet air is 25 + 5 ° F.

5.2.1.9. If suction pressure is above values outlined in Section 4.3.13 the expansion valve must be turned CCW in 1/2 revolution increments, waiting 2-5 minutes for valve to stabilize, until desired value is obtained and/or air outlet temperature is the lowest possible.



**General Servicing and
Maintenance
R-12**

- 5.2.1.10.** If suction pressure is lower than values outlined Section 4.3.13 the expansion valve must be turned CW in accordance with same procedure as discussed in paragraph 5.2.1.9.
- 5.2.1.11.** Allow system to operate for 5-10 minutes after expansion valve adjustment to verify setting.
- 5.2.1.12.** If system contains multiple evaporator modules, go to section 5.3.
- 5.2.1.13.** Shut system off and replace all shrouds, enclosures, ducting as required and remove charging manifold gauges and hose assy.

WARNING: EYE AND HAND PROTECTION SHOULD BE WORN DURING THIS OPERATION.

5.3. Valve Balancing Procedure:

The expansion valves must be balanced on systems with multiple evaporators. This process balances refrigerant flow between evaporators to achieve equal evaporator air outlet temperatures:

- 5.3.1.** Access all of the evaporator modules and measure / record outlet air temperatures.
- 5.3.2.** Adjust the expansion valve on the evaporator with the highest outlet air temperature 1/4 revolution in a CW direction. This will increase the refrigerant flow and reduce the outlet air temperature.
- 5.3.3.** Adjust the remaining evaporator(s) with a lower outlet air temperature 1/4 revolution CCW.
- 5.3.4.** Allow system to stabilize, recheck the evaporator outlet temperatures and repeat adjustment procedure if required. Evaporator outlet temperatures should be within 1-3°F of each other

NOTE: Proper evaporator balancing should not result in a change of the compressor suction pressure. Verify system pressures are within values shown in Section 4.3.13.

- 5.3.5.** If evaporator outlet temperatures are equal and suction pressure meets Section 4.3.13 servicing is complete. If not, repeat sections 5.2 and 5.3.
- 5.3.6.** Shut system off and replace all shrouds, enclosures, ducting as required and remove charging manifold gauges and hose assembly.



**General Servicing and
Maintenance
R-12**

6. COMPRESSOR DRIVE BELT INSPECTION & MAINTENANCE

6.1. General:

- 6.1.1. Inspection of the compressor drive train components according to the Inspection Schedule (Section 12 Table 4) is recommended. A visual inspection should verify proper belt alignment and detect premature component wear. Examine the belt and pulleys for excessive and/or uneven wear.
- 6.1.2. When the compressor drive belt requires removal and replacement, tensioning or alignment the following procedures will apply:
- 6.1.3. Special Tools And /Or Equipment Required
 - Small hand tools and socket set.
 - Eye protection.
 - Enviro Belt Tensioning Tool P/N T1134610.
 - Wagner Spring Scale P/N FDK-10.

6.2. Belt Removal Procedure:

- 6.2.1. Verify all aircraft or ground power to motor is off.
- 6.2.2. Remove all access panels and exhaust ducts to gain access to compressor module.
- 6.2.3. Remove all fasteners securing the belt guard assy.
- 6.2.4. With socket and box end type wrenches slightly loosen the two 3/8 bolts that support the R-12 compressor.
- 6.2.5. Loosen (ccw turn) tension nut on compressor side of rod end bearing and swing compressor down to loosen belt.
- 6.2.6. Loosen socket head set screws in motor pulley and slide pulley off motor shaft while at the same time sliding the drive belt off the compressor pulley.

NOTE: This procedure assures that the motor pulley flange and belt are not damaged during removal.

CAUTION: DO NOT BEND OR TWIST EXCESSIVELY THE DRIVE BELT DURING REMOVAL OR DAMAGE MAY RESULT.

- 6.2.7. Inspect belt for cracks or missing teeth and clean any oil or other contamination from both pulleys and belt.

6.3. Drive Belt Replacement Procedure:

- 6.3.1. Verify belt size and part number before installing or damage may result.
- 6.3.2. Verify #3 woodruff key is installed on motor shaft.
- 6.3.3. Place belt on motor pulley and slide pulley on end of motor shaft and at the same time slide belt over compressor pulley. Slightly tap motor pulley on shaft until belt completely covers compressor pulley.

EFFECTIVITY: ALL

21-00-00
Page 19
OCTOBER 05, 2011



**General Servicing and
Maintenance
R-12**

NOTE: Verify the belt teeth are in the grooves of each pulley and during installation slightly rotate both pulleys to assure proper engagement.

CAUTION: DURING THIS PROCEDURE DO NOT SHARPLY BEND OR TWIST THE BELT AND DO NOT ALLOW BELT TO ROTATE ON MOTOR PULLEY FLANGE. DAMAGE TO BOTH MAY RESULT.

- 6.3.4. After belt is installed, rotate the compressor pulley clockwise to align belt on pulley. Belt must ride directly over the compressor pulley.

NOTE: If the belt is too far forward or aft on the compressor pulley the motor pulley must be adjusted fore or aft to allow belt to ride directly over compressor pulley.

- 6.3.5. If belt alignment is good, slightly tighten the two (2) 3/8 compressor support bolts and turn rod end bearing adjust nut until snug.

6.4. Drive Belt Alignment Procedure:

- 6.4.1. Loosen motor pulley set screws, if required, with pulley on shaft and rotate compressor pulley clockwise (cw). At the same time slide the motor pulley forward or aft until the belt rides directly over the compressor pulley.
- 6.4.2. Slightly tighten motor pulley set screws and rotate the compressor pulley (cw) for approximately ten (10) revolutions to assure belt is tracking as required. If so, tighten set screws.

CAUTION: ALL BOLTS AND NUTS MUST BE SLIGHTLY TIGHT BEFORE ALIGNMENT IS PERFORMED OR GROSS BELT AND/OR COMPRESSOR ALIGNMENT MAY RESULT.

- 6.4.3. Belt is ready for tensioning.

6.5. Drive Belt Tensioning Procedure:

- 6.5.1. Verify all the compressor mounting hardware is slightly tight and belt is properly aligned.
- 6.5.2. Apply hand pressure to the compressor to increase belt tension and tighten upper compressor mounting bolt.

NOTE: A Wagoner FDK-10 spring loaded force gage is required for this procedure.

CAUTION: DO NOT OVER TENSION BELT. BELT OR MOTOR BEARING DAMAGE MAY RESULT.

- 6.5.3. Place Enviro belt tension tool on drive belt and orient as shown in Figure 2.
- 6.5.4. Position the spring scale into the pilot hole on the tensioning fixture corresponding to the belt mid-span between pulleys.
- 6.5.5. Depress the spring scale until the plunger housing contacts the tension tool surface.

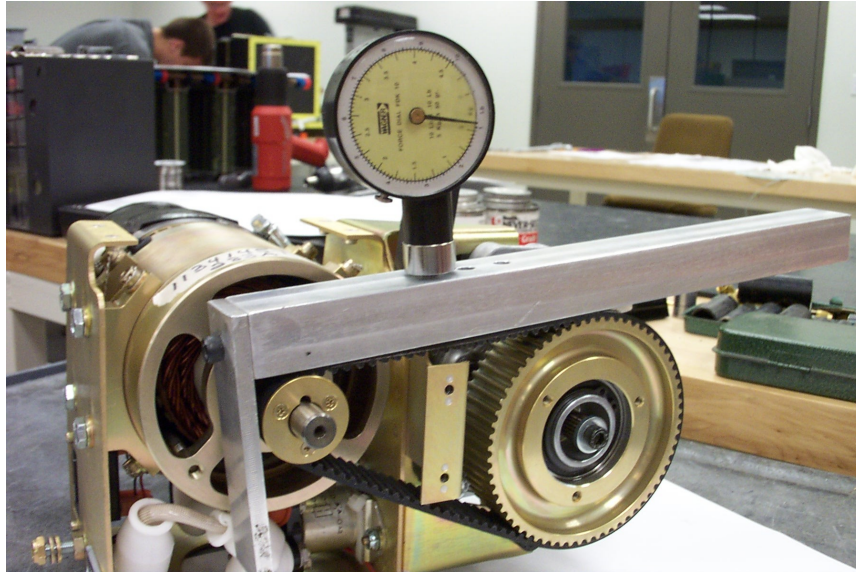

Figure 2 Belt Alignment

6.5.6. The scale should indicate a load of 1.50 to 1.75 lbs.

NOTE: This is equivalent to a belt deflection of 0.10 inch with a mid-span force of 1.50 to 1.75 pounds.

6.5.7. Repeat Sections 6.5 until proper tension is achieved.

6.5.8. When proper belt tension is obtained tighten compressor mounting bolts Torque the nuts to 175-200 in-lbs.

6.5.9. Recheck belt alignment as described in Section 6.4 and adjust as required.



**General Servicing and
Maintenance
R-12**

7. COMPRESSOR DRIVE MOTOR INSPECTION AND MAINTENANCE

A periodic brush inspection is required to assure that excessive damage to the motor commutator or armature does not occur. Perform replacement of the brushes according to the Inspection Schedule (Section 12, Table 4)

7.1. Drive Motor Inspection

7.1.1. Special Tools Or Equipment:

- Small hand tools and socket set.
- Micrometer
- Scribe or wire hook.
- Volt - OHM meter (digital)
- Shop air, 40 psig (max)
- Inspection mirror

7.1.2. Inspection of the drive motor will consist of, but not limited to, the following:

- Brush wear inspection
- Commutator wear inspection
- Internal contamination inspection
- Bearing noise inspection

7.2. Motor Brush Inspection Procedure:

WARNING: MAKE INSPECTION EVERY 300 HOURS LOGGED ON AIRFRAME HOUR METER. CHECK HOUR METER ON COMPRESSOR CONDENSER MODULE FOR MANDATORY BRUSH REPLACEMENT SCHEDULE

- 7.2.1.** Verify all electrical power is off to system.
- 7.2.2.** Remove all access panels and exhaust ducts to gain access to the drive motor.
- 7.2.3.** Disconnect power leads from motor terminals (1/4 - 28). Tag positive lead
- 7.2.4.** Remove condenser support bracket to provide access to brush cover fasteners and remove motor cuff shroud.
- 7.2.5.** Loosen and unsnap brush cover assy. Remove from motor.
- 7.2.6.** With wire, hook or scribe lift brush spring and remove brush.
- 7.2.7.** Inspect brush for cracks, chipped edges, frayed leads, loose rivets or shunt connections. Replace defective brush(s).
- 7.2.8.** Continue inspection until all brushes have been observed. In addition, inspect brush holders and springs for looseness, as well as damage from arcing, heat distortion or cracks.
- 7.2.9.** With brushes removed and using shop air at 40 psig (max) and nozzle. Blow out as much carbon and/or copper dust as possible out of the commutator, armature and field windings. Purge from the commutator end of the motor.



**General Servicing and
Maintenance
R-12**

WARNING: EYE AND MOUTH PROTECTION MUST BE USED DURING THIS OPERATION OR EXCESSIVE LUNG AND EYE IRRITATION WILL RESULT. DO NOT DIRECT AIR JET ON BEARINGS OR INTERNAL CONTAMINATION WILL RESULT.

CAUTION: DURING BRUSH REPLACEMENT DO NOT ALLOW BRUSH SPRING TO SNAP INTO PLACE QUICKLY OR DAMAGE TO BRUSH MAY RESULT. ALSO, DO NOT CHIP OR SCRATCH BRUSH CONTACT SURFACE DURING INSTALLATION.

7.2.10. Replace existing brushes in brush holder with brush chamfer leading edge pointing in the direction of rotation of the commutator.

CAUTION: BRUSHES MUST SLIDE EASILY UP AND DOWN THE BRUSH RACK, IF THEY DO NOT LIGHTLY SAND THE SIDES OF THE BRUSHES UNTIL THEY DO.

7.3. Commutator Wear Inspection:

While the brushes are removed for inspection the commutator must be inspected for excessive or uneven wear. The commutator should have a burnished appearance with light filming. If the commutator is black, burned, pitted or excessively worn, the motor should be replaced. If the depth of the mica undercut remaining on the commutator is less than .020 inch the motor should be replaced.



Excellent Condition
Commutator is still bright and shows little sign of wear.

Figure 3.3: Commutator Excellent Condition Example

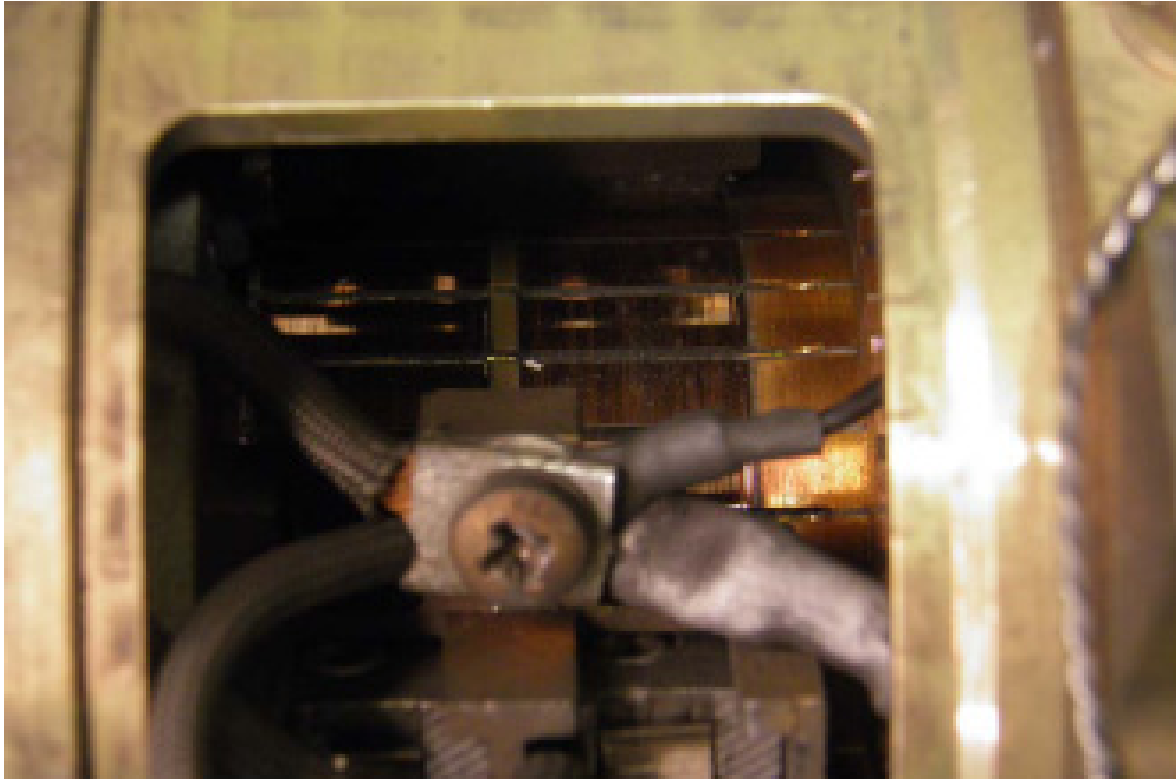

Serviceable Condition

Shows some signs of wear and carbon build up

Figure 3.4: Commutator Serviceable Condition Example



Figure 3.5: Commutator Unserviceable Condition Example

Unserviceable Condition
Shows excessive pitting and chipping on commutator

7.4. Motor Insulation Resistance Check:

After the inspection of the commutator a quick check of the motor insulation resistance should be performed. This check may be done with or without the brushes installed but the power leads must be removed from the motor during this procedure.

- 7.4.1.** Verify power off and power leads disconnected.
- 7.4.2.** With OHM meter positive lead connected to the motor positive terminal and the other lead connected to motor case (ground) measure and record resistance. Resistance value must be equal to or greater than 10,000 OHMS. If less resistance is measured the motor should be replaced.

7.5. Internal Contamination Inspection:

- 7.5.1.** Verify that no foreign matter is lodged in the motor air intake or field winding areas.
- 7.5.2.** Inspect for excessive moisture in motor or corrosion of parts.
- 7.5.3.** Purge motor and air passages as required removing any dust, dirt or other contamination.



**General Servicing and
Maintenance
R-12**

7.6. Motor Bearing Inspection:

CAUTION: INSPECT MOTOR BEARING TO ASSURE THAT PREMATURE SEIZURE DOES NOT OCCUR.

- 7.6.1. Verify power is off and motor is accessible.
- 7.6.2. On unitized systems (containing a condenser coil assembly) disconnect compressor discharge hose clamp and remove condenser support bracket to access brush cover.
- 7.6.3. Remove brush cover. On some systems removal of motor power leads is required prior to brush cover removal, tag positive terminal.
- 7.6.4. Remove brushes from brush guides Section 7 and remove belt from motor pulley as outlined in Section 6.
- 7.6.5. Rotate motor shaft by hand to ensure freedom of rotation. Visually inspect bearing for sign of overheating or loss of lubrication with an inspection mirror.
- 7.6.6. If bearings are good install belt and brushes. Check belt alignment and tension per procedure.

CAUTION

CAREFULLY LAY BRUSH SHUNT LEADS IN A POSITION WHICH WILL PREVENT ANY POSSIBLE SHORTING PROBLEMS. LEADS MUST BE ABLE TO EASILY FOLLOW BRUSH AND SPRING MOVEMENT AS WEAR OCCURS. IMPROPER LEAD PLACEMENT MAY RESULT IN MOTOR DAMAGE.

- 7.6.7. Replace brush cover and tighten and safety wire (8-32 UNC) brush cover screws. Replace motor cooling fan shroud.
- 7.6.8. Connect power leads to motor terminals and tighten (1/4 - 28) nuts.
- 7.6.9. Replace condenser bracket.

7.7. Motor Brush Replacement

CAUTION MOTOR BRUSHES MUST BE REPLACED ACCORDING TO SECTION 12 TABLE 4 MAINTENANCE SCHEDULE.

- 7.7.1. Special Tools Or Equipment:
 - Small hand tools and socket set.
 - Micrometer
 - Scribe or wire hook.
 - Volt - OHM meter (digital)
 - Shop air, 40 psig (max)
 - Inspection mirror
- 7.7.2. New brushes may be installed by first level maintenance personnel only under the following conditions:
 - Motor was operating correctly prior to brush replacement.

EFFECTIVITY: ALL



**General Servicing and
Maintenance
R-12**

- Motor inspection did not show any defects which would require motor replacement.
- Only approved vendor brushes are used.
- Brushes are installed, seated and tested in accordance with the following procedures.

7.7.3. Perform brush inspection procedure as outlined paragraph 7.2 (as required).

7.7.4. Verify all power is off, all panels, shrouds, brackets and fairings are removed.

7.7.5. With a stiff wire hook or scribe lift brush spring from holder and remove each worn brush set, until all four brush sets are removed.

7.7.6. Remove brush shunt wire terminal screw and discard worn brush set. Continue this step until all four screws are removed.

CAUTION: DO NOT ALLOW BRUSH SPRING TO SNAP HARD INTO PLACE OR DAMAGE TO BRUSH MAY RESULT.

7.7.7. Install each brush set by lifting brush springs, sliding brush into holder (with brush leading edge in direction of rotation) and lightly releasing the brush spring on the brush. (See figure 6).

CAUTION: BRUSHES MUST SLIDE EASILY UP AND DOWN THE BRUSH RACK, IF THEY DO NOT LIGHTLY SAND THE SIDES OF THE BRUSHES UNTIL THEY DO.

7.7.8. Verify that brush seats flat on the commutator and that no binding in holder is present. Align brush spring in center of brush groove.

CAUTION: DO NOT CROSSTHREAD OR OVER APPLY TORQUE BRUSH LEAD SCREWS OR THREAD DAMAGE MAY RESULT.

7.7.9. Install terminal screw and lock washer on brush shunt lead and other leads and tighten. Repeat this step for other brush sets.

7.7.10. Seat the new brushes according to the following procedure. All new brushes must be seated to assure proper motor operation and performance. If motor is operated without seating the motor warranty may be voided.

CAUTION: EXCESSIVE SEATING IS NOT ADVISED. BRUSH LIFE MAY BE REDUCED. REMOVE GRIT PAPER AND BLOW OUT ALL CARBON DUST FROM COMMUTATOR AND BRUSH AREA.

WARNING: EYE, NOSE AND THROAT PROTECTION MUST BE WORN DURING THIS PROCEDURE.

7.7.10.1. Cut 4 inch long by 1.5 inch wide strip of 400-500 grit paper and place, with rough side out, on motor commutator.

7.7.10.2. Secure one end of the paper to the commutator with masking tape in a manner such that the taped end will lead in the direction of shaft rotation (ccw looking at fan end). The other end will remain loose and overlap the taped end.



**General Servicing and
Maintenance
R-12**

- 7.7.10.3.** Raise each brush momentarily while rotating the shaft until the taped end has passed under each brush. After the grit paper is properly located tight against the commutator and encompasses all brush surface area, carefully rotate the armature, by hand, in the normal direction of rotation until a full seat is obtained on each new brush. Three to four rotations is generally adequate.
- 7.7.11.** Carefully lay brush shunt leads in position such as to prevent any shorting problems. Leads must be able to easily follow brush and spring movement as brush wear occurs.
- 7.7.12.** Replace brush cover and power leads.
- 7.7.13.** Replace all brackets and hardware removed to access motor.
- 7.7.14.** Visually inspect motor to assure all brackets are installed, cooling fan does not interfere with shroud, motor drive belt installed, aligned, tensioned and belt cover installed.
- 7.7.15.** The motor should be tested or run in to verify proper operation. Connect ground power source or verify aircraft power on and turn system on.
- 7.7.16.** Run system for a minimum of 15 minutes to seat brushes and check motor operation.
- 7.7.17.** Turn system and aircraft power off. System is ready for use.

7.8. Motor Removal:

- 7.8.1.** Verify all aircraft or ground power off.
- 7.8.2.** Remove access doors, exhaust ducting and/or enclosure to gain access to motor assembly.

CAUTION: DO NOT DAMAGE PULLEY FLANGE DURING REMOVAL.

- 7.8.3.** Remove belt cover, drive belt and pulley, receiver dryer (if required) and condenser support bracket. Refer to section 7.0 for belt and pulley removal. If unit is not installed in aircraft motor removal will be simplified by removing condenser coil.
- 7.8.4.** Disconnect power leads and tag.
- 7.8.5.** Remove 8 ea. 5/16 mounting bolts from support bracket.

CAUTION: DURING THIS OPERATION DO NOT LET MOTOR FALL ON POWER CONTACTOR OR DAMAGE MAY RESULT.

- 7.8.6.** Remove all wires tie strapped to the motor, slightly lift motor up and turn 90 Deg. to remove from mounting bracket.
- 7.8.7.** With motor free, remove drive pulley.
- 7.8.8.** Disconnect motor positive (red) and negative (black) leads from 3/8 relay stud and 1/4 unit grounding bolt, respectively.



**General Servicing and
Maintenance
R-12**

- 7.8.9. Remove fan blade from motor by unscrewing 3/8 locknut from motor shaft and loosening fan hub set screw with 1/8 inch allen wrench. Access fan hub set screw through the Ø.0187 hole in the blade root area.

7.9. Motor Replacement:

- 7.9.1. Apply thread sealant to fan hub set screw. Place fan assembly on motor shaft and align set screw with flat on shaft. Tighten set screw slightly. Secure condenser fan to motor shaft using 3/8 inch washer and locknut, hold fan while tightening locknut. Tighten fan hub set screw.
- 7.9.2. Connect motor positive (red) lead to 3/8 relay terminal.
- 7.9.3. Connect motor negative lead to 1/4-28 unit grounding bolt.
- 7.9.4. Position motor into mounting bracket with keyed shaft end toward compressor pulley

CAUTION: DO NOT DAMAGE POWER CONTACTOR OR CONDENSER FINS DURING THIS OPERATION

- 7.9.5. Replace motor support bolts and lock washers and torque to 10-15 in-lbs, except bolts for belt guard bracket and upper compressor support.
- 7.9.6. Install upper compressor support bracket and verify alignment with compressor mounting ear. Torque the compressor support mounting bolts to 10-15 in-lbs.
- 7.9.7. Secure motor and control wiring with cable ties and route to prevent chaffing.
- 7.9.8. Install condenser support bracket on motor support using 6-32unc fillister screws.

CAUTION: ADJUST FAN SHROUD TO ASSURE THAT FAN BLADE DOES NOT HIT. ROTATE FAN TO VERIFY.

- 7.9.9. Attach condenser coil assembly, if required. Align condenser fan shroud to achieve uniform blade tip clearance. Seal fan shroud with RTV sealant
- 7.9.10. Replace motor pulley and drive belt (ref. section 7.0)
- 7.9.11. Align and tension belt as required in section 7.0
- 7.9.12. Install belt guard assembly, fasteners and tighten
- 7.9.13. Verify all hardware and brackets are secure and all fillister screws are properly safety wired.
- 7.9.14. Replace exhaust ducting, unit enclosures and access panels.
- 7.9.15. Operate system to verify motor and system are functioning correctly



**General Servicing and
Maintenance
R-12**

8. COMPRESSOR ASSY R-12 INSPECTIONS AND MAINTENANCE

The compressor assy. requires more inspection than maintenance since field repair with first line technicians is limited. Inspection consists of checking for excessive oil leaks, belt alignment, proper tension and refrigerant leaks. Check the compressor according to the Inspection and Maintenance Schedule (Section 11 Table 4)

8.1. Special Tools And Equipment Required:

- Small hand tools and socket set.
- Charging manifold with gauges and hoses
- Electronic leak detector
- Refrigerant (R-12) 14oz. cans
- Leak check fluid, (soapy solution)
- Hand and eye protection
- Thread sealant (Loctite)
- Dry nitrogen, regulated
- Refrigerant can dispensing valve
- Reclaim/ Recycle Unit I(UL Approved)

8.2. Compressor Inspection Procedure:

- 8.2.1. Verify ground power on aircraft power to system is off.
- 8.2.2. Remove access doors, exhaust ducts and enclosure to gain access to compressor.
- 8.2.3. Remove belt cover and inspect for belt alignment and tension. (Ref. section 7.0)
- 8.2.4. Visually inspect compressor pulley for excessive wear, nicks, cracks or looseness.
- 8.2.5. Visually inspect compressor output shaft for excessive oil leaks.

NOTE If excessive oil is noted the compressor should be checked for leaks. Use fluid or leak detector as required. If leak is noted the compressor should be replaced. If compressor has not been operated for 30-60 days or more the dynamic shaft seal may indicate a small leak due to no oil on dynamic seal surface. Operation of system should eliminate this type leak. If not, replace R-12 compressor.

- 8.2.6. Check all fasteners for looseness. Re-torque as required.
- 8.2.7. Visually check drive belt for cracks, wear and excessive oil. With clean shop rag clean all oil and other contamination from belt cogs.

NOTE Checking compressor oil quantity is only required if an excessive amount of oil is observed leaking or the system has been vented very quickly thereby causing a loss of oil. An oil check can only be made with the system vented. (See oil check procedure.)

- 8.2.8. If visual check is good, replace belt cover and secure fasteners.

8.3. Compressor Removal:

- 8.3.1. Verify ground and aircraft power is off to the system.
- 8.3.2. Repeat requirements as detailed in paragraph 9.2.2 as required.



**General Servicing and
Maintenance
R-12**

- 8.3.3. Connect refrigerant manifold gauge and hose assy. to compressor suction and discharge service valves.
- 8.3.4. Recover system refrigerant charge as detailed in reclaim systems operating manual.
- 8.3.5. Remove belt guard assembly.
- 8.3.6. Loosen compressor mounting bolts and release belt tension
- 8.3.7. Remove drive belt and motor pulley as described in section 7.0.
- 8.3.8. Remove system suction and discharge hose connections and cap off immediately.

CAUTION: ALL SYSTEM CONNECTIONS MUST BE CAPPED TO PREVENT WATER, DUST OR ANY OTHER CONTAMINATION FROM ENTERING THE SYSTEM.

- 8.3.9. Remove compressor mounting bolts and lift compressor free of mounting bracket.

8.4. Compressor Replacement:

If a new or rebuilt compressor is supplied without suction and discharge swivel fittings or pulley, these parts must be removed from the failed compressor and installed on the new compressor. It is recommended that a complete, new compressor assy. be installed.

CAUTION IF FAILED COMPRESSOR HAS CONTAMINATED THE SYSTEM A COMPLETE CLEANING AND PURGE OF THE SYSTEM IS REQUIRED. ALSO THE RECEIVER-DRYER ASSY. MUST BE REPLACED. FLUSH SYSTEM WITH ISOPROPYL ALCOHOL AND PURGE WITH NITROGEN. ALSO REMOVE & CLEAN EXPANSION VALVES.

- 8.4.1. Lift compressor into support bracket and install support bolts, washers and nuts. Place rod end bearing into adjustment hole in motor support bracket and install washers and nut.
- 8.4.2. Snug lower compressor mounting bolts and rotate compressor toward drive motor centerline and install drive belt.
- 8.4.3. Replace, align and tension belt per paragraphs 7.3 thru 7.4. Replace belt guard.

CAUTION: NEW COMPRESSOR IS SUPPLIED WITH A SLIGHT INTERNAL (NITROGEN) PRESSURE. REMOVE CAPS AND VENT SLOWLY.

NOTE: Lightly apply refrigerant oil on compressor fitting (s) flare and apply a small amount of thread sealant to fitting threads (stay clear of first 2-3 threads).

- 8.4.4. Remove compressor suction and discharge fitting caps and connect system hoses.
- 8.4.5. Tighten o-ring fitting nuts to 150-200 in-lbs. Do not over torque.
- 8.4.6. Connect R-12 manifold gauge and hose assy. to suction and discharge service ports.
- 8.4.7. If failed compressor contaminated system and system was cleaned and purged an additional charge of refrigerant oil is required.



**General Servicing and
Maintenance
R-12**

- 8.4.7.1. If failed compressor did not contaminate the system no additional oil is required since the new compressor contains the required charge.
- 8.4.7.2. In either case, the receiver-dryer assy. must be replaced.
- 8.4.7.3. Oil is added to compressor from a port located on top of compressor between the service ports.

8.4.8. Leak check system per section 4.0 as required.

8.4.9. Charge system per section 5.0 as required.

8.4.10. Operate system to verify compressor operation and system performance.

8.5. Compressor Oil Level Check:

When replacing the failed compressor containing uncontaminated oil with a new compressor, use the following procedure to add required oil to system.

8.5.1. Drain and measure oil from the failed compressor.

8.5.2. Drain and measure oil from new compressor in a clean container for reuse.

CAUTION: ONLY AN ENVIRO APPROVED TYPE OF OIL MAY BE USED IN THIS TYPE COMPRESSOR CONTACT ENVIRO FOR APPROVED OIL TYPE.

CAUTION: DO NOT OVERFILL COMPRESSOR WITH OIL, SYSTEM PERFORMANCE WILL BE AFFECTED.

8.5.3. Measure an amount of new oil equal to the amount drained from the used compressor. Pour it into the new compressor.



9. EVAPORATOR MODULE INSPECTION AND MAINTENANCE

Only field serviceable high inspection or maintenance components will be addressed in the evaporator module section. Inspections must be according to the Inspection and Maintenance Schedule (Section 11 Table 4)

9.1. Evaporator Coil Inspection:

The evaporator coil must be inspected for excessive lent and/or other contamination in the coil fins. Clean as required by using vacuum or low pressure purge source. Bent fins must be combed to straighten.

9.2. Condensate Drain And Tubing Inspection:

Verify that the evaporator condensate drain and associated tubing is not blocked or tubing kinked. Clean and re-route tubing as required.

9.3. Cool Air Ducting Inspection:

Cool air ducting from the evaporator blower should be checked to assure that no excessive air loss is experienced due to loose connections, cracked or kinked hose. Repair as required.

9.4. Evaporator Module Blower Motor Removal And Replacement

The evaporator module blower motor is a low cost item and does not contain replaceable brushes. Therefore, it is recommended that the motor be replaced rather than repaired.

9.4.1. Motor Removal:

9.4.1.1. Verify all power to unit is off and all shrouds, enclosures, etc. are removed from around the module/blower assy.

NOTE: The blower motor is a permanent magnet type and therefore may be wired to rotate either CW or CCW. It is necessary that the motor wires and associated colors be observed before being disconnected.

9.4.1.2. Disconnect power leads to motor.

9.4.1.3. For motors which rotate CW (looking at output shaft) the motor red wire is + 28 VDC and the black wire is ground. For CCW rotation the red wire is ground and the black wire is + 28 VDC.

NOTE: At this point it is very important to observe the wire colors and connections from the resistor assembly and motor and record them.

9.4.1.4. Remove motor wire clamp and disconnect the wire splice from the resistor wire.

- The resistor red wire is the low speed control
- The orange wire is the high speed.

9.4.1.5. Remove motor mounting screws and with a putty or pocket knife slide between the motor and plastic scroll to cut the RTV sealant bonding. Avoid damage to the scroll.

CAUTION: DO NOT DAMAGE BLOWER WHEEL DURING REMOVAL OR AN OUT OF BALANCE CONDITION MAY RESULT.



**General Servicing and
Maintenance
R-12**

9.4.1.6. Lift blower motor out of scroll assy. and remove blower wheel.

9.4.1.7. Discard blower motor since brush replacement is not possible.

9.4.2. Blower Motor And Wheel Replacement:

CAUTION: DURING WHEEL INSTALLATION, DO NOT BEND OR SMASH WHEEL.

9.4.2.1. Replace motor wheel on new motor shaft where the back of the wheel is .25 inches from the motor mounting surface. The set screw on the wheel hub must be located on the motor shaft flat section. Use a thread lock sealant and tighten set screw.

9.4.2.2. Rotate blower wheel on motor shaft to check wheel wobble. Lightly apply a force on the wheel O.D. to eliminate any wobble as required.

NOTE: Observe blower wheel blade and verify leading edge is in direction of rotation.

9.4.2.3. Apply a small bead of RTV sealant (or gasket seal if equipped) on the scroll and install the blower wheel and motor with motor wires in a location near the resistor wires and mounting screw.

CAUTION: DO NOT OVER-TORQUE MOUNTING SCREWS OR THREAD DAMAGE MAY RESULT.

9.4.2.4. Install all mounting screws and tighten snugly as required.

9.4.2.5. With access thru the blower outlet rotate the blower wheel to assure that no rubbing exists.

9.4.2.6. Connect motor and resistor wiring as follows:

- CW ROTATION: Splice motor red wire onto resistor orange wire, using wire splice, which runs straight through. Motor black wire, (ground.) and the resistor red wire also run straight through (no splice).
- CCW ROTATION: Motor black wire is spliced into resistor orange wire, using wire splice, which runs straight through. Motor red wire, is covered with black shrink tube (ground.) and along with resistor red wire also straight through (no splice).

9.4.2.7. Wire color hookup is as follows:

- Black – Ground
- Orange - +28 VDC, Hi Speed
- Red - +28 VDC Lo Speed

9.4.2.8. Run all wires thru the wire clamp and secure with mounting screw and washer.

9.4.2.9. Connect power leads to blower assy. and test for proper operation.

9.4.2.10. Replace all ducting, shrouds and enclosures, etc. Unit is ready for operation.

9.5. Expansion Valve Removal And Replacement:

EFFECTIVITY: ALL



**General Servicing and
Maintenance
R-12**

9.5.1. Valve Removal:

9.5.2. The automatic expansion valve normally does not require replacement. However, in the unlikely event it malfunctions or it has a clogged inlet filter the following procedures will apply:

9.5.2.1. The refrigerant system charge must be reclaimed and to the expansion valves must be accessible.

WARNING: EYE AND HAND PROTECTION SHOULD BE WORN IN THE EVENT SYSTEM IS STILL UNDER PRESSURE. PLACE CAP ON OPEN SYSTEM PORTS.

9.5.2.2. Remove valve inlet tubing and remove valve from coil tubing header.

9.5.2.3. Inspect valve inlet filter for contamination and clean. If no contamination is noted, valve should be replaced if operation was erratic prior to removal.

CAUTION: DO NOT ADJUST INTERNAL SPRING SETTING OR VALVE WILL NOT OPERATE CORRECTLY.

9.5.2.4. Inspect valve internal works to verify that no contamination exists in the seat or orifice. Clean and purge as required.

9.5.3. Valve Replacement:

9.5.3.1. Set new valve adjustment screw to same position of failed valve.

9.5.3.2. Apply thread sealant (sparingly) to male fitting inlet and outlet port threads avoiding the first 2-3 threads. Apply a very slight amount of refrigerant oil to both valve port flare surfaces Do not put oil on fitting threads.

CAUTION: USE BACKUP WRENCH DURING TIGHTENING AND DO NOT OVERTORQUE "B" NUT.

9.5.3.3. Install valve in coil header and position as required. Tighten connection to 190-195 in-lbs.

9.5.3.4. Connect valve inlet port tubing and tighten.

9.5.3.5. Leak check, evacuate and charge system per sections 4.0 and 5.0.

9.5.3.6. Operate system and verify valve is performing as required. Adjust valve, according to section 4.0 and section 5.0



**General Servicing and
Maintenance
R-12**

10. TROUBLE SHOOTING THE R-12 AIRCONDITIONING SYSTEM

10.1. Diagnosis

10.1.1. There may a time when the system does not operate and/or perform in accordance with information contained herein. Therefore, it is necessary for the service personnel to diagnose the discrepancy by trouble shooting the system and its components.

10.1.2. To assist in the diagnoses refer to Table 3 Diagnosis and Trouble Shooting. The list of system and component failure and/or abnormal operation and possible solutions are only a partial listing of what may occur. The more informed the service personnel are in the operation of the system and its various components will reduce the time to diagnose failures and may add other probable causes to the list.

NOTE: Refer to refrigerant and electrical schematics Figures 4 and 5 respectively.

Indication	Probable Cause	Possible Solution
A. No System Power	1. Ground power not connected	1. Plug in ground power cart
	2. Aircraft power switch off	2. Energize power switch
B. Power On But System Will Not Operate	1. Air conditioner breaker off	1. Turn on
	2. Air conditioner breaker failed	2. Replace
	3. Air conditioner mode switch failed	3. Replace
	4. Relay(s) failed	4. Replace
	5. Failed pressure switch	5. Replace
	6. Failed drive motor	6. Replace
	7. Vented system	7. Pressure check, evacuate and charge
	8. Low ambient temperature	8. Normal cut out function
	9. Drive motor fuse blown	9. Replace
	10 Drive motor temp sw failed	10 Replace switch
	11. Contactor control line fuse blown	11. Replace

Table 3 Diagnosis and Trouble Shooting



**General Servicing and
Maintenance
R-12**

Indication	Probable Cause	Possible Solution
C. System Operates But Does Not Cool	1. Low refrigerant charge	1. Charge as required
	2. Overcharged system cutout	2. Reclaim refrigerant as required
	3. Failed Compressor	3. Replace
	4. Failed Drive Motor	4. Replace
	5. Broken Belt	5. Replace
	6. Failed expansion valve(s)	6. Replace
	7. Evaporator blower switch failed	7. Replace
	8. Evaporator blower motor failed	8. Replace
	9. evaporator blower failed	9. Replace
	10. evaporator blowers circuit breaker	10. Energize or Replace
	11. Relays failed	11. Replace
	12. Evaporator module air inlet clogged	12. Remove Debris
	13. Expansion valve inlet clogged	13. Remove Debris
	14. Excessive moisture in system	14. Replace receiver dryer
	15. Excessive oil in system	15. Drain excessive oil
D. Evaporator Noisy	1. Blower wheel out of round	1. Replace
	2. Blower wheel hitting scroll	2. Align
	3. Defective blower motor bearing	3. Replace motor
	4. Loose mounting bracket	4. Tighten hardware
	5. Air inlet clogged	5. Remove debris

Table 3 Diagnosis and Trouble Shooting Continued



**General Servicing and
Maintenance
R-12**

Indication	Probable Cause	Possible Solution
E. Compressor Noisy	1. Loose drive belt	1. Tension belt
	2. Drive belt hitting cover	2. Align belt & adjust bracket
	3. Motor fan hitting shroud	3. Adjust as required
	4. Defective compressor	4. Replace
	5. Defective drive pulley	5. Replace
	6. Loose pulley	6. Tighten or replace
	7. Loose mounting hardware	7. Tighten as required
	8. Loose hose assembly	8. Secure as required
	9. Loose fan blade	9. Tighten or replace
F. No low evap. Fan speed (hi speed ok)	1. Failed switch	1. Replace
	2. Failed resistor	2. Replace
	3. Failed relay	3. Replace

Table 3 Diagnosis and Trouble Shooting Continued



**General Servicing and
Maintenance
R-12**

11. COMPONENT INSPECTION, SERVICING AND/OR MAINTENANCE SCHEDULE

11.1. Required Inspections, Maintenance, and Replacement

Component	Type Maintenance	Required Inspections Times
Refrigerant System R-12	Performance check Visual	500 Hours or 12 Months
Compressor R-12 Assembly	Leak check shaft seal Bearing inspection Bearing Replacement Oil Level check	500 Hours or 12 Months 500 Hours or 12 Months On condition On condition
Compressor Drive Motor	Brush inspection	12 Months
	Brush replacement	Mandatory 500 Hours
	Bearing inspection	500 Hours or 12 Months
	Bearing replacement	On condition
	Motor overhaul	2500-3000
Drive Belt (Pulleys)	Visual inspection	500 Hours or 12 Months
	Tension and alignment	500 Hours or 12 Months
	Replacement	On condition
Power Contactor	Inspection Replacement	None On condition
Receiver Dryer Assembly	Refrigerant charge level Replacement with compressor replacement If internal desiccant is exposed to moisture, due to line rupture or being left uncapped.	500 Hours or 12 Months On condition Mandatory
Expansion Valve	Adjustment Replacement	As Required On condition
Pressure Switch	Replacement	On condition
Evaporator Blower Motor	Inspect for cleanliness, damage, integrity. Service life	500 Hours or 12 Months 1500-2000

11.1.1. The following Table 4 is a required component maintenance/inspection schedule with associated service hours:

Table 4 Maintenance Schedule



**General Servicing and
Maintenance
R-12**

12. SYSTEM OFF SEASON FUNCTIONAL TESTS:

12.1. General:

- 12.1.1.** If ambient temperature is below 50° F (10°C), the pressure switch is designed to keep the system from operating and causing possible damage if operated for extended periods of time. In this case, it is recommended that the aircraft be heated above this threshold to enable the system to operate.

CAUTION: OPERATION OF THE SYSTEM AT LOW AMBIENT TEMPERATURES FOR MORE THAN 15 MINUTES CAN RESULT IN MAJOR DAMAGE OF THE R-12 COMPRESSOR.

12.2. Procedures

- 12.2.1.** During cold winter months, the system should be operated for 10-15 minutes every two weeks to maintain a thin oil film on the compressor output shaft dynamic seal to prevent shaft leakage.
- 12.2.2.** Prior to turning on the air conditioning system (energizing the compressor drive), run blowers on high speed for a minimum of 5 minutes. This will aid in warming the refrigerant and bringing it up to an acceptable temperature enabling operation of the system.



**General Servicing and
Maintenance
R-12**

13. SYSTEM LONG TERM SHELF STORAGE

13.1. Storage and Procedures Terms

- 13.1.1.** If unit is stored for periods in excess of 12 months the following preventative maintenance should be followed for the compressor.

NOTE: When installing unit with MFG date in excess of 12 months, prior to installation date, verify record of preventative maintenance. If no maintenance record exist contact Enviro Systems Inc. prior to installation.

- 13.1.2.** Perform the following procedures at 12 months from MFG date on unit and every 6 months thereafter for a maximum of 36 months.

13.2. Internal Pressures

- 13.2.1.** For internal pressure within a range of 5-15 PSIG rotate compressor by hand through a minimum of 10 revolutions.
- 13.2.2.** For internal pressure below 5 PSIG the system should be pressurized to 15 PSIG using regulated dry nitrogen. After pressurizing the system, rotate the compressor by hand through a minimum of 10 revolutions.
- 13.2.3.** If the system does not have any detectable pressure, check the compressor oil for contamination.

13.3. Contamination Check

- 13.3.1.** Remove compressor oil plug and insert a clean tie strap into oil fill hole. To inspect the oil remove the strap. Oil should have a clear to amber color.
- 13.3.2.** If oil shows specs of black or other contamination, the compressor must be flushed and the receiver dryer must be replaced. The compressor should then be evacuated for a minimum of 30 minutes and then pressurized to 15 PSIG according to Section 4.



**General Servicing and
Maintenance
R-12**

14. COMPONENT WARRANTY CONSIDERATIONS:

14.1. Warranties

14.1.1. Unit or component warranty may be denied should any of the following conditions occur:

- Component damaged due to negligence
- Component disassembled
- Component altered in configuration
- Component failure due to refrigerant system contamination or improper charge
- Component not serviced or maintained correctly
- Component out of warranty
- Component not returned in proper shipping container (Use same container that the component was shipped in)
- Component repaired or overhauled with parts not FAA/PMA approved
- Component ports not capped
- Component warranty claim filed incorrectly



**General Servicing and
Maintenance
R-12**

15. SERVICE PRECAUTIONS:

15.1. Refrigerant Handling

- 15.1.1.** Always wear eye and hand protection when servicing an air conditioning system. Liquid refrigerant can cause frostbite or blindness.

15.2. Recovery Of Refrigerant

- 15.2.1.** Do not discharge R-12 refrigerant into the atmosphere. Although the ozone depletion potential is zero, it can have an effect on global warming. In the United States recovery and recycling are mandated by the Clean air Act..Refrigerant recovery/recycling service equipment must be approved for use with R-12 refrigerant.
- 15.2.2.** Recycling machines must be approved by Underwriters Laboratories and meet SAE standard J2210 and SAE standard j2099 for refrigerant purity.

15.3. Ventilation

- 15.3.1.** Keep refrigerants and oils away from open flames. Refrigerants can produce poisonous gasses in the presence of a flame. Work in a well ventilated area and avoid breathing refrigerant /lubricant vapor mist if accidental discharge occurs.

15.4. Avoid Use Of Compressed Air

- 15.4.1.** Do not introduce compressed air or oxygen into an air conditioning system or refrigerant container. R-12 in the presence of air or oxygen above atmospheric pressure may form a combustible mixture.

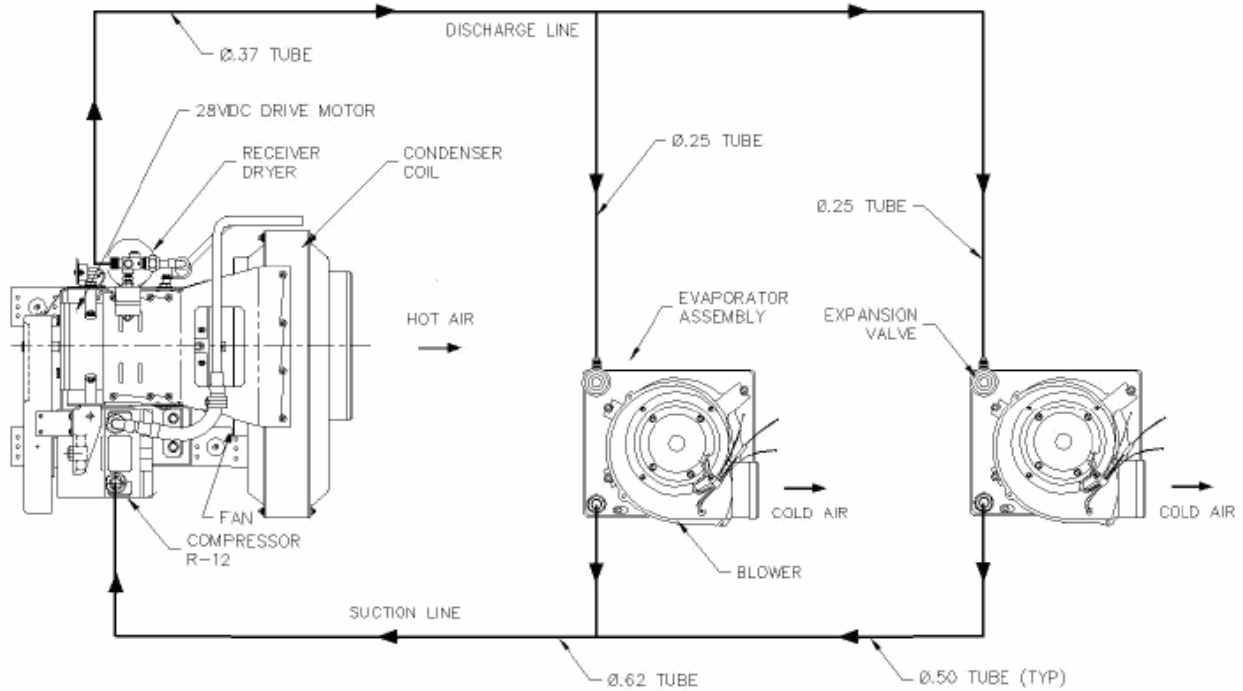

Figure 4 Air Conditioning System

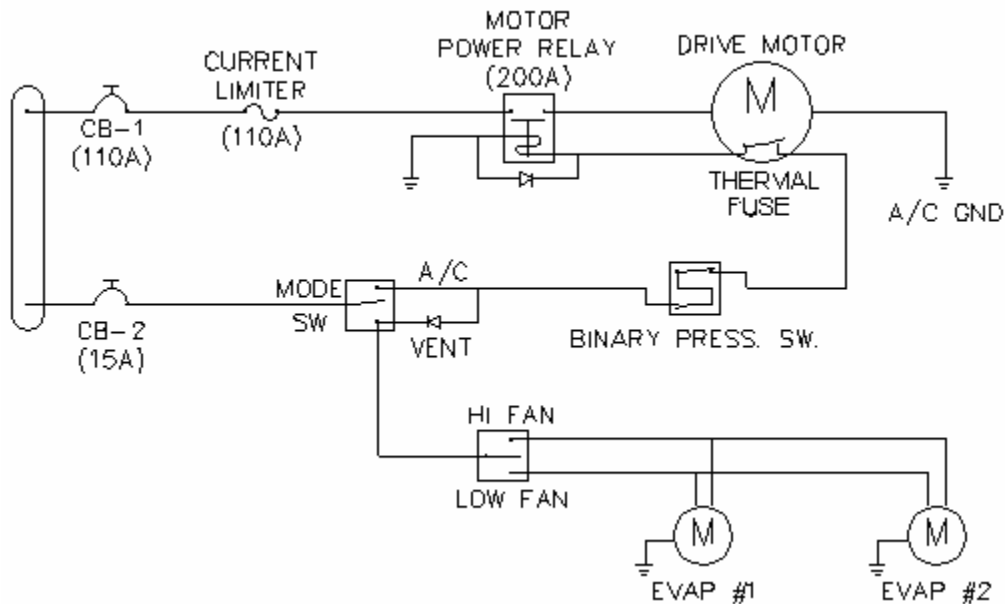

Figure 5 Electrical Schematic