

Keith Products, Inc
Illustrated Parts Catalog

Keith Products, Inc
Air Conditioning System for Sikorsky S-76 Helicopter

<u>Section</u>	<u>Component</u>
21-50-00	Air Conditioning System
21-50-01	Compressor/ Condenser Assembly
21-50-02	Evaporator Assembly
21-50-03	Plumbing

Illustrated Parts Catalog

Document No. 85-02-101-1SM

PREPARED BY Todd Seach

CHECKED BY MS

APPROVED M. J. Allen

INITIAL ISSUE: April 10, 1995

DATE: July 21, 2006

JUL 21 2006
RELEASE DATE

Keith Products, Inc
 Illustrated Parts Catalog

LIST OF EFFECTIVE PAGES

<u>CHAPTER</u>	<u>SECTION</u>	<u>SUBJECT</u>	<u>PAGE</u>	<u>DATE</u>
		Title	1	July 21/06
		Record of Revisions	1	July 21/06
		Service Bulletin List	1	April 10/95
		List of Effective Pages	1	July 21/06
		Table of Contents	1	April 10/95
		Introduction	1	April 10/95
			2	April 10/95
	21-50-00		1	April 10/95
			2	April 10/95
	21-50-01		1	April 10/95
			2	July 21/06
			3	April 10/95
			4	April 10/95
			5	April 10/95
			6	April 10/95
			7	April 10/95
			8	July 21/06
			9	April 10/95
			10	April 10/95
	21-50-02		1	April 10/95
			2	April 10/95
			3	April 10/95
			4	April 10/95
			5	April 10/95
			6	April 10/95
			7	April 10/95
			8	April 10/95
	21-50-03		1	April 10/95
			2	April 10/95
			3	April 10/95
			4	April 10/95

TABLE OF CONTENTS

<u>Subject</u>	<u>Chapter Section Subject</u>	<u>Page</u>
<u>INTRODUCTION</u>		1
<u>AIR CONDITIONING SYSTEM</u>	21-50-00	
Figure 1		1
<u>COMPRESSOR/CONDENSER ASSY</u>	21-50-01	
Figure 1		1
Figure 2		6
<u>EVAPORATOR ASSY</u>	21-50-02	
Figure 1		1
Figure 2		5
<u>PLUMBING</u>	21-50-03	
Figure 1		1
Figure 2		3

INTRODUCTION

1. PURPOSE

The purpose of this Illustrated Parts Catalog is to provide detailed parts breakdown of the Keith Products, Inc. air conditioning system for the Sikorsky S-76 helicopter.

This manual covers the three separate air conditioning systems available from Keith Products. Air conditioning system 85-02-101-1 uses Freon R-12 refrigerant. Air conditioning system 85-02-101-2 uses R-134a refrigerant. Air conditioning system 85-02-101-3 also uses R-134a refrigerant and is a higher cooling capacity system. The Keith Products air conditioning system is installed in accordance with STC SH5778SW.

2. SCOPE

The scope of the Illustrated Parts Catalog (IPC) provides the maintenance technician with detailed information covering:

- An IPC covering the breakdown of each major component of the air conditioning system, including part number and relevant illustrations.

3. ARRANGEMENT

This Illustrated Parts Catalog is arranged in accordance with Air Transport Association (ATA) Specification 100.

4. GLOSSARY

Nonstandard abbreviations and symbols used in the IPC are described below.

Abbreviations:

ADJ	-	Adjustment
A/R	-	As Required
Assy	-	Assembly
Blwr	-	Blower
Evap	-	Evaporator
IPC	-	Illustrated Parts Catalog
L	-	Lower
Mod	-	Module
STC	-	Supplemental Type Certificate

Keith Products, Inc
Illustrated Parts Catalog

SV - Service Valve
U - Upper

5. DETAILED PARTS LIST

The detailed parts list contains listing of assemblies and detailed parts arranged in disassembly sequence. The parts are illustrated on the referenced figure number.

A - Item Numbers

Item numbers on view illustrations are referenced in the "Item No." column of the Parts List.

B - Part Numbers

Numbers in the "Part No." column are used for identification and ordering of replacement parts. Only those parts with numbers are available as replacement items.

C - Nomenclature

Names in the "Nomenclature" column are also used for identification and ordering of replacement parts.

D - Effect

Parts that apply only to certain assemblies are noted with that assembly dash number in the "Effect" column.

E - Units Per Assembly

Numbers listed in "Units per Assembly" column indicate the total quantity of parts used per unit. Illustrations may not show the total quantity of that part per unit.

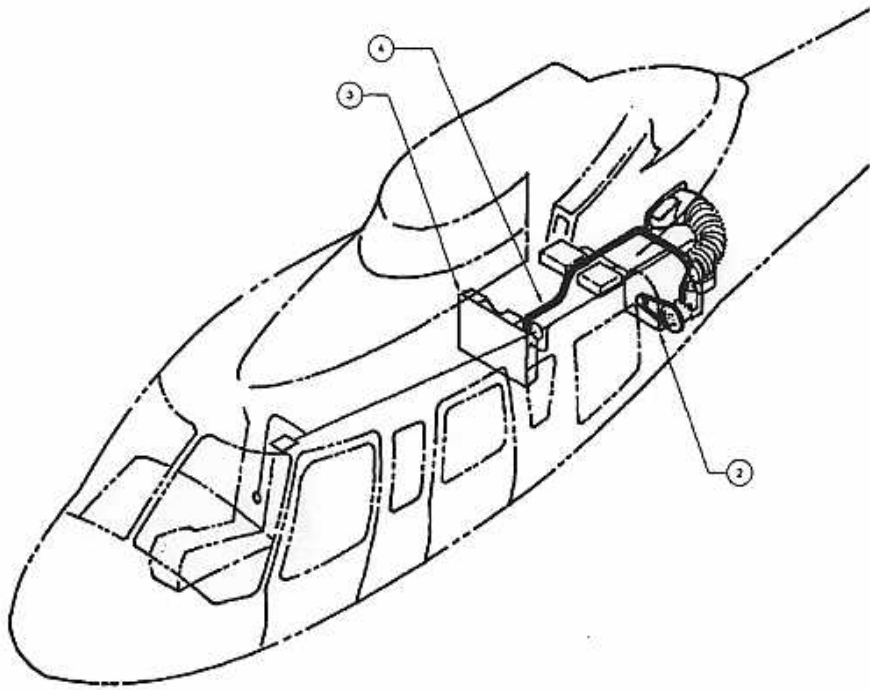

85-02-101 Air Conditioning System
Figure 1

Keith Products, Inc
 Illustrated Parts Catalog

FIG. ITEM	PART NUMBER	NOMENCLATURE	EFFECT	UNITS PER ASSY
1 1	85-02-101-1	Air Conditioning System (R-12)		RF
	85-02-101-2	Air Conditioning System (R-134a)		RF
	85-02-101-3	Air Conditioning System (R-134a High Capacity)		RF
2	JBS5001-1	Pallet Assembly	-1	1
	JBS5001-6	Pallet Assembly	-2	1
	JBS5004-1	Pallet Assembly	-3	1
3	85-02-202-1	Evaporator Assembly	-1	1
	85-02-202-2	Evaporator Assembly	-2	1
	85-02-203-1	Evaporator Assembly	-3	1
4	85-02-110-1	Plumbing	-1	1
	85-02-110-2	Plumbing	-2	1
	85-02-110-3	Plumbing	-3	1

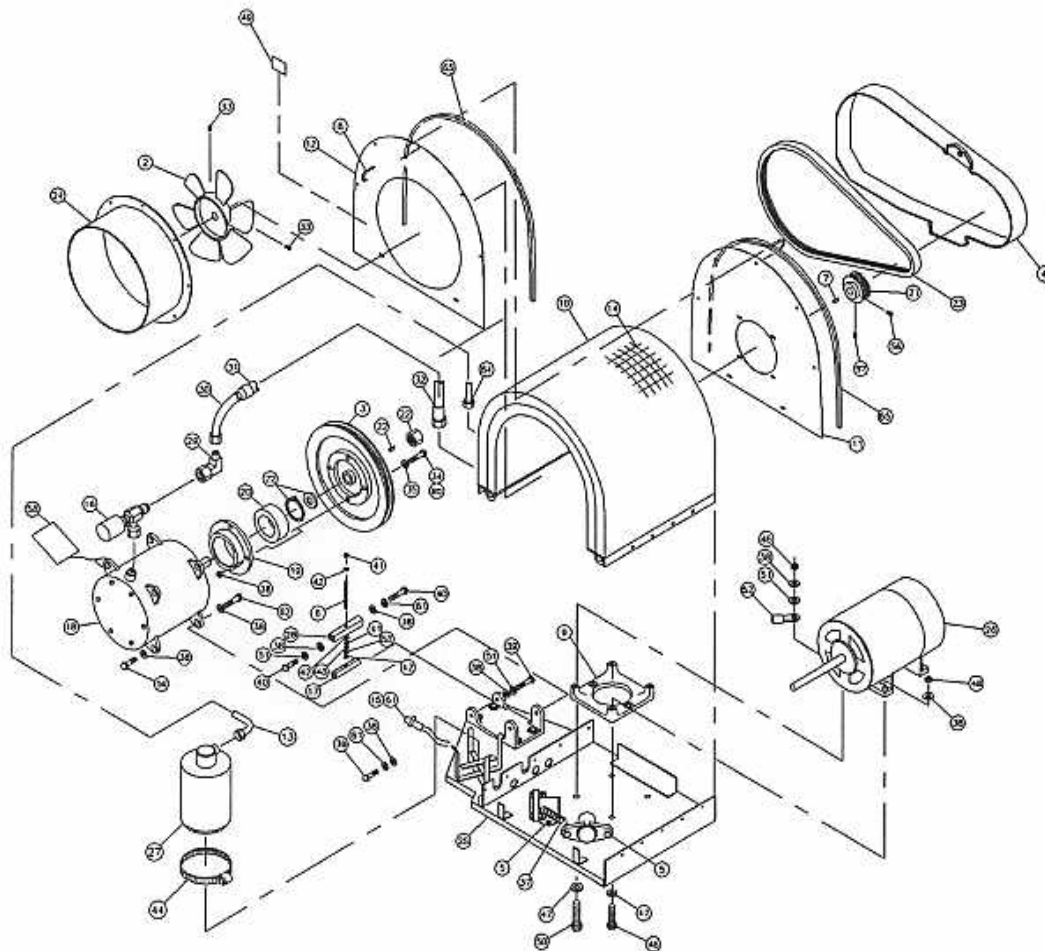

JBS5001 Compressor/Condenser Pallet Assembly
Figure 1

Keith Products, Inc
 Illustrated Parts Catalog

FIG. ITEM	PART NUMBER	NOMENCLATURE	EFFECT	UNITS PER ASSY
1	1	JBS5001-1 JBS5001-6	Pallet Assy Pallet Assy	RF RF
	2	JBS2024-2	Fan Blade Assy (8 in dia)	1
	3	JBS14001-3	Ribbed Pulley	1
	4	JBS15001-1	Belt Guard Assy	1
	5	JBS56-1	Relay	2
	6	JBS59-8	Stud	1
	7	JBS80-1	Key	1
	8	JBS407-2	Clip	5
	9	JBS430-3	Bracket, Motor Mount	1
	10	JBS464-14	Condenser Assembly	1
	11	JBS15003-1	Endplate	1
	12	JBS15003-2	Endplate	1
	13	JBS598-5	Tube Assy	1
	14	JBS550-8	Screen	1
	15	ES53006-1	Contact Pin	4
	16	JBS2020-1	Pressure Switch Assy	1
	17	JBS806-3	Adj. Bracket	1

Keith Products, Inc
 Illustrated Parts Catalog

FIG. ITEM	PART NUMBER	NOMENCLATURE	EFFECT	UNITS PER ASSY
1 18	JBS201-4	Compressor Assembly	-1	1
	JBS201-14	Compressor Assembly	-6	1
19	JBS93-6	Bearing Carrier		1
20	ES20146-1	Bearing		1
21	JBS14002-2	Drive Pulley		1
22	ES20145-2	Kit		1
23	ES20040-2	Ribbed Belt		1
24	JBS567-4	Fan Duct		1
25	JBS554-5	Pallet Sub Assy		1
26	ES61100-1	Motor		1
27	ES43029-3	Receiver/Dryer		1
28	JBS806-2	Adj. Bracket		1
29	ES41046-2	Swivel Fitting		1
30	ES40050-2	Fitting		1
31	ES48149-2	Hose		13 in.
32	ES40049-1	Fitting		1
33	ES31030-4	Set Screw		2
34	AN3H12A	Bolt		4
35	AN960-10L	Washer		8

Keith Products, Inc
 Illustrated Parts Catalog

FIG. ITEM	PART NUMBER	NOMENCLATURE	EFFECT	UNITS PER ASSY
1 36	AN364-1032	Nut		4
37	JBS912-1	Spring Resistor		1
38	AN960-416	Washer		12
39	AN4-6A	Bolt		2
40	AN4-11A	Bolt		2
41	MS21042L5	Nut		2
42	AN960-516L	Washer		3
43	AN315-5R	Nut		1
44	ES30042-5	Clamp		1
45	MS21042-4	Nut		1
46	AN4-23A	Bolt		3
47	AN970-4	Washer		4
48	AN365-428	Nut		3
49	JBS10-42	Placard		1
50	AN4-24A	Bolt		1
51	AN935-416L	Lockwasher		7
52		Ground Terminal		RF
53	AN935-516	Lockwasher		1
54	ES42013-2	Nut		1

Keith Products, Inc
 Illustrated Parts Catalog

FIG. ITEM	PART NUMBER	NOMENCLATURE	EFFECT	UNITS PER ASSY
1 55	ES00106-2	Shroud Trim Extrusion		(2) 32 in.
56	ES31030-2	Set Screw		1
57	ES31030-3	Set Screw (On Key)		1
58	JBS15004-1	Placard		1
59	AN4-10A	Bolt		1
60	MS209995C32	Lockwire		AR
61	ES53004-1	Receptacle		1
62	AN4-12A	Bolt		1

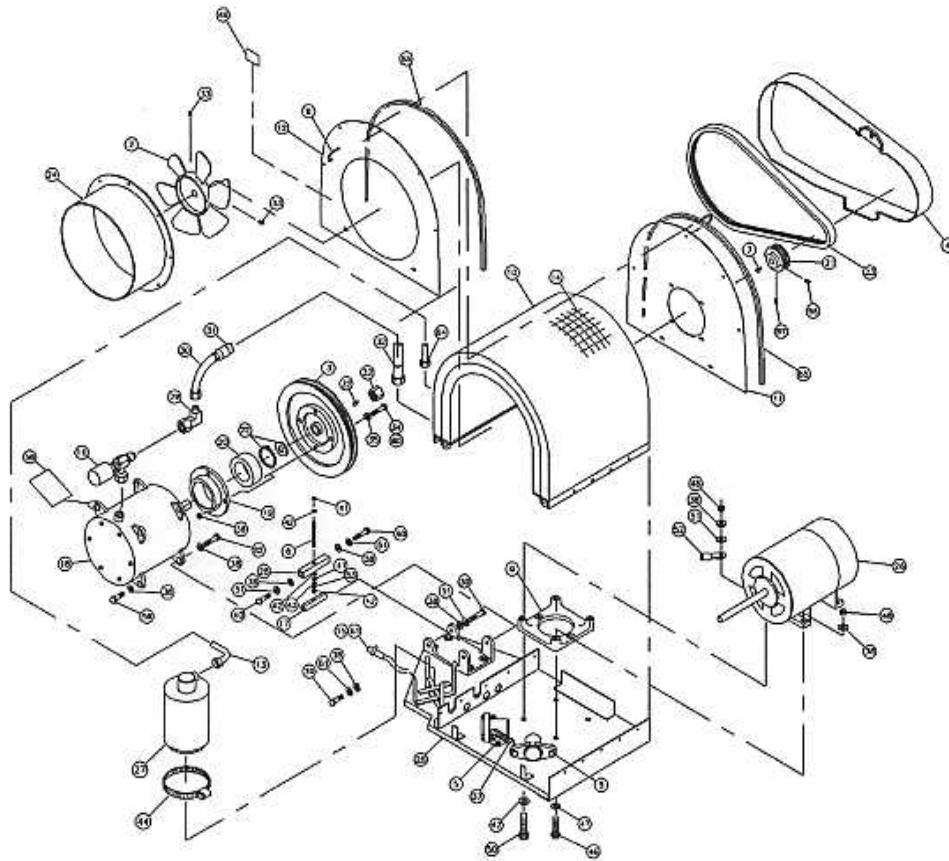

JBS5004 Compressor/Condenser Pallet Assembly
Figure 2

Keith Products, Inc
Illustrated Parts Catalog

Keith Products, Inc
 Illustrated Parts Catalog

FIG. ITEM	PART NUMBER	NOMENCLATURE	EFFECT	UNITS PER ASSY
2 1	JBS5004-1	Pallet Assembly		RF
2	JBS2024-2	Fan Blade Assy (8 in dia)		1
3	JBS14001-2	Ribbed Pulley		1
4	JBS15001-1	Belt Guard Assy		1
5	JBS421-7	Relay		2
6	JBS59-8	Stud		1
7	JBS80-1	Key		1
8	JBS407-2	Clip		5
9	JBS430-3	Bracket, Motor Mount		1
10	JBS464-17	Condenser Assembly		1
11	JBS15003-1	Endplate		1
12	JBS15003-2	Endplate		1
13	JBS598-10	Tube Assy		1
14	JBS550-8	Screen		1
15	ES53006-1	Contact Pin		4
16	JBS2020-5	Pressure Switch Assy		1
17	JBS806-3	Adj Bracket		1
18	JBS221-1	Compressor Assembly		1

Keith Products, Inc
 Illustrated Parts Catalog

FIG. ITEM	PART NUMBER	NOMENCLATURE	EFFECT	UNITS PER ASSY
2 19	JBS93-7	Bearing Carrier		1
20	ES20086-1	Bearing		1
21	JBS14002-2	Drive Pulley		1
22	ES20145-2	Kit		1
23	ES20040-2	Ribbed Belt		1
24	JBS567-4	Fan Duct		1
25	JBS554-3	Pallet Sub Assy		1
26	ES61100-1	Motor		1
27	ES43030-2	Receiver/Dryer		1
28	JBS806-2	Adj Bracket		1
30	ES40151-2	Fitting		1
31	ES48149-2	Hose		18 in
32	ES40149-2	Fitting		1
33	ES31030-4	Set Screw		2
34	AN3H12A	Bolt		4
35	AN960-10L	Washer		8

Keith Products, Inc
 Illustrated Parts Catalog

FIG. ITEM	PART NUMBER	NOMENCLATURE	EFFECT	UNITS PER ASSY
2 36	AN364-1032	Nut		4
37	JBS912-1	Spring Resistor		1
38	AN960-416	Washer		12
39	AN4-6A	Bolt		2
40	AN4-11A	Bolt		2
41	MS21042L5	Nut		2
42	AN960-516L	Washer		3
43	AN315-5R	Nut		1
44	ES30042-5	Clamp		1
45	MS21042-4	Nut		1
46	AN4-23A	Bolt		3
47	AN970-4	Washer		4
48	AN365-428	Nut		3
49	JBS10-42	Placard		1
50	AN4-24A	Bolt		1
51	AN935-416L	Lockwasher		11
52		Ground Terminal		RF

Keith Products, Inc
 Illustrated Parts Catalog

FIG. ITEM	PART NUMBER	NOMENCLATURE	EFFECT	UNITS PER ASSY
2 53	AN935-516	Lockwasher		1
54	ES42090-2	Nut - O-ring		1
55	ES00106-2	Shroud Trim Extrusion		(2) 32 in.
56	ES31030-2	Set Screw		1
57	ES31030-3	Set Screw (On Key)		1
58	JBS15004-1	Placard		1
59	AN4-10A	Bolt		1
60	MS20995C32	Lockwire		AR
61	ES53004-1	Receptacle		1
62	AN4-12A	Bolt		1
63	ES49011-2	O-Ring		3
64	ES49011-1	O-Ring		2

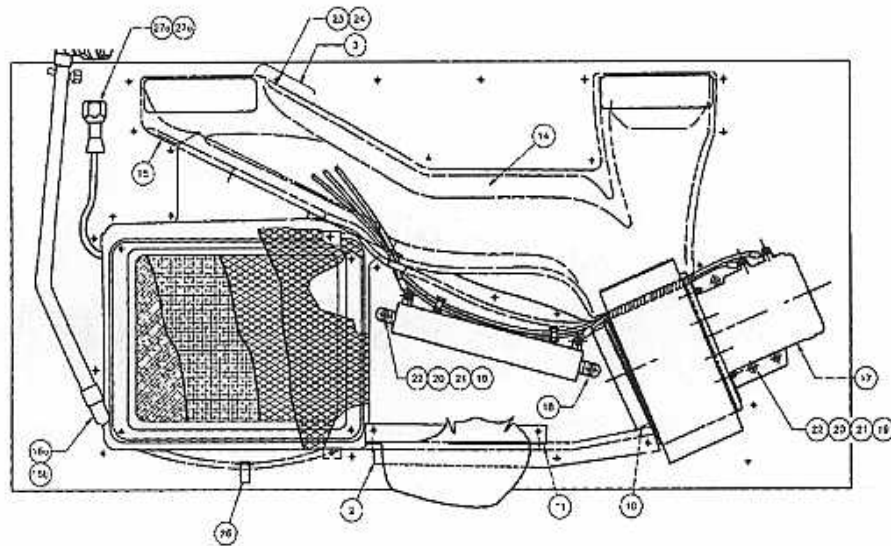

85-02-202 Evaporator Assembly
Figure 1 (Sheet 1)

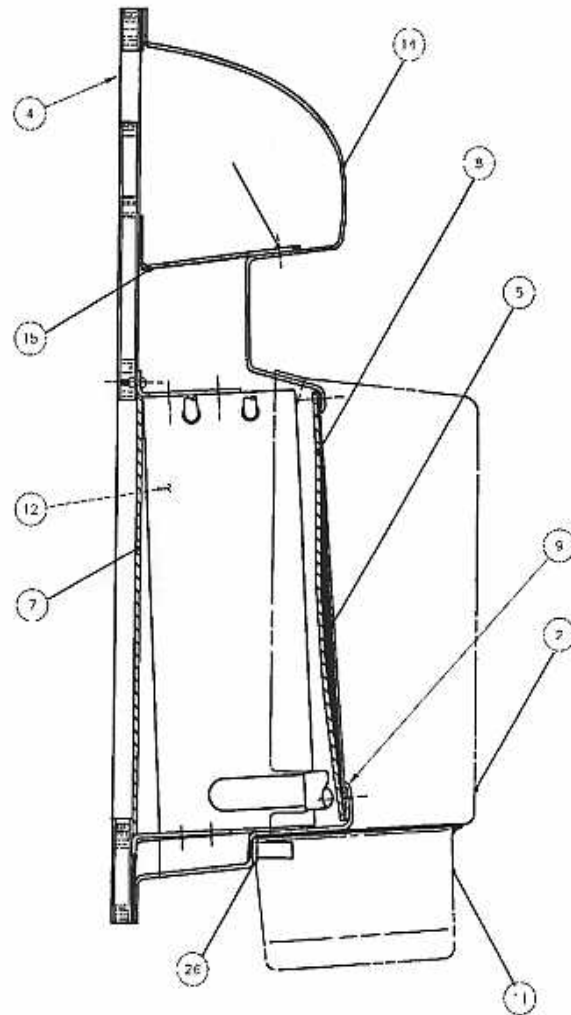

85-02-202 Evaporator Assembly
Figure 1 (Sheet 2)

Keith Products, Inc
 Illustrated Parts Catalog

FIG. ITEM	PART NUMBER	NOMENCLATURE	EFFECT	UNITS PER ASSY
1	1	85-02-202-1	Blwr/Evap Mod. Assy	RF
		85-02-202-2	Blwr/Evap Mod Assy	RF
	2	85-02-402-1	Tunnel, Blower	1
	3	85-02-402-6	Module Cover (U)	1
	4	85-02-402-7	Panel	1
	5	85-02-402-8	Filter	1
	6	85-02-402-9	Screen	1
	7	85-02-402-10	Grill	1
	8	85-02-402-11	Grill	1
	9	85-02-402-12	Module Cover (L)	1
	10	85-02-402-13	Collar	1
	11	85-02-402-14	Sump	1
	12	85-02-402-15	Cover, Tube	1
	14	85-02-402-17	Duct & Evap. Coil Cover	1
	15	85-02-402-21	Baffle	1
	16a	JBS2023-2	Coil, Evaporator	-2
	16b	JBS2023-1	Coil, Evaporator	-1
	17	ES73103-2	Blower	1

Keith Products, Inc
 Illustrated Parts Catalog

FIG. ITEM	PART NUMBER	NOMENCLATURE	EFFECT	UNITS PER ASSY
1 18	ES63014-7	Resistor		1
19	NAS221-17	Screw		6
20	AN960-10L	Washer		7
21	AN970-3	Washer		6
22	MS20365-1032	Nut		8
23	AN525-8R14	Screw		10
24	AN960-8L	Washer		47
26	ES49006-1	Drain		1
27a	ES26101-6	Expansion Valve	-1	1
27b	ES26101-1	Expansion Valve	-2	1

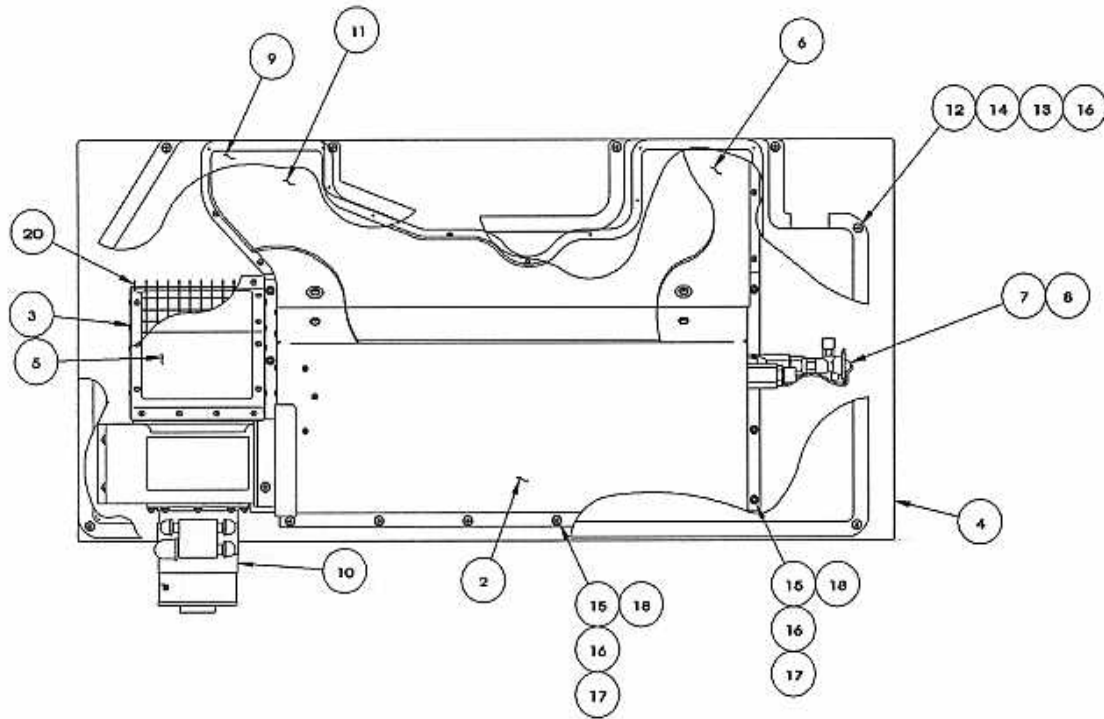

85-02-203 Evaporator Assembly
Figure 2 (Sheet 1)

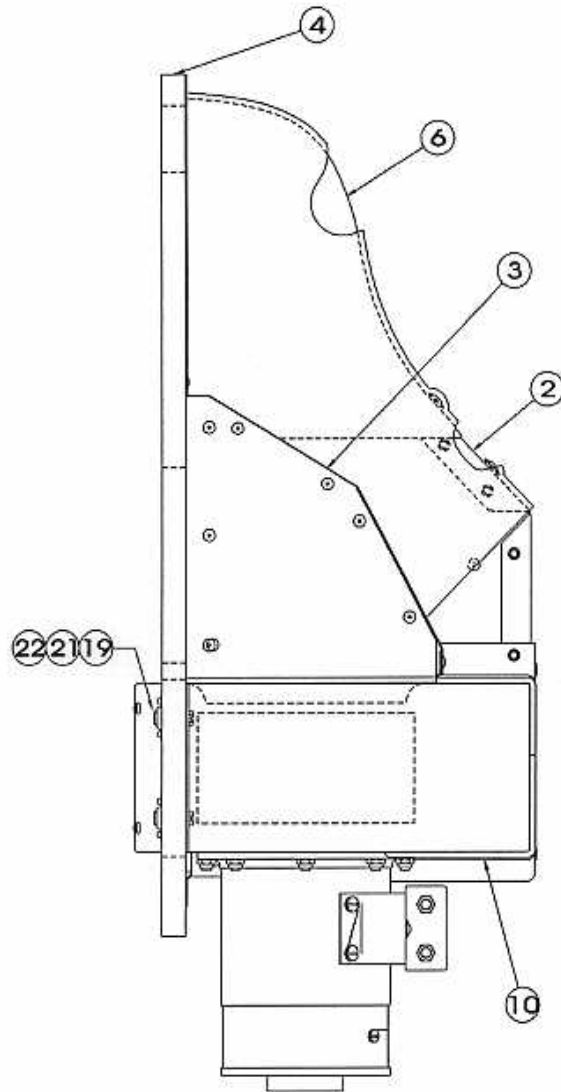

(* EVAPORATOR COVER ASSY
NOT SHOWN FOR CLARITY)

85-02-203 Evaporator Assembly
Figure 2 (Sheet 2)

Keith Products, Inc
 Illustrated Parts Catalog

FIG. ITEM	PART NUMBER	NOMENCLATURE	EFFECT	UNITS PER ASSY
2 1	85-02-203-1	Evap. Blwr. Mod. Assy		RF
2	85-02-203-10	Evap. Support Assy.		1
3	85-02-203-11	Inlet Duct Assy.		1
4	85-02-401-21	Panel		1
5	85-02-401-9	Inlet Cover		1
6	85-02-405-1	Evaporator Duct		1
7	ES26104-1	Expansion Valve		1
8	ES49011-1	O-Ring		1
9	85-02-406-2	Evap. Cover Assy.		1
10	85-02-205-1	Blower Assembly		1
11	ES02163-5	Insulation		720 in.
12	AN525-832R8	Screw		7
13	MS27130-A13	Rivnut		7
14	AN935-8L	Lockwasher		7
15	AN365-832	Nut		12

Keith Products, Inc
 Illustrated Parts Catalog

FIG. ITEM	PART NUMBER	NOMENCLATURE	EFFECT	UNITS PER ASSY
2 16	AN960-8L	Washer		19
17	AN970-3	Washer		10
18	AN525-832R14	Screw		12
19	AN3-7A	Screw		3
20	ES04006-1	Screen		37.5 in.
21	AN960-10L	Washer		3
22	MS21059L3	Nutplate		3

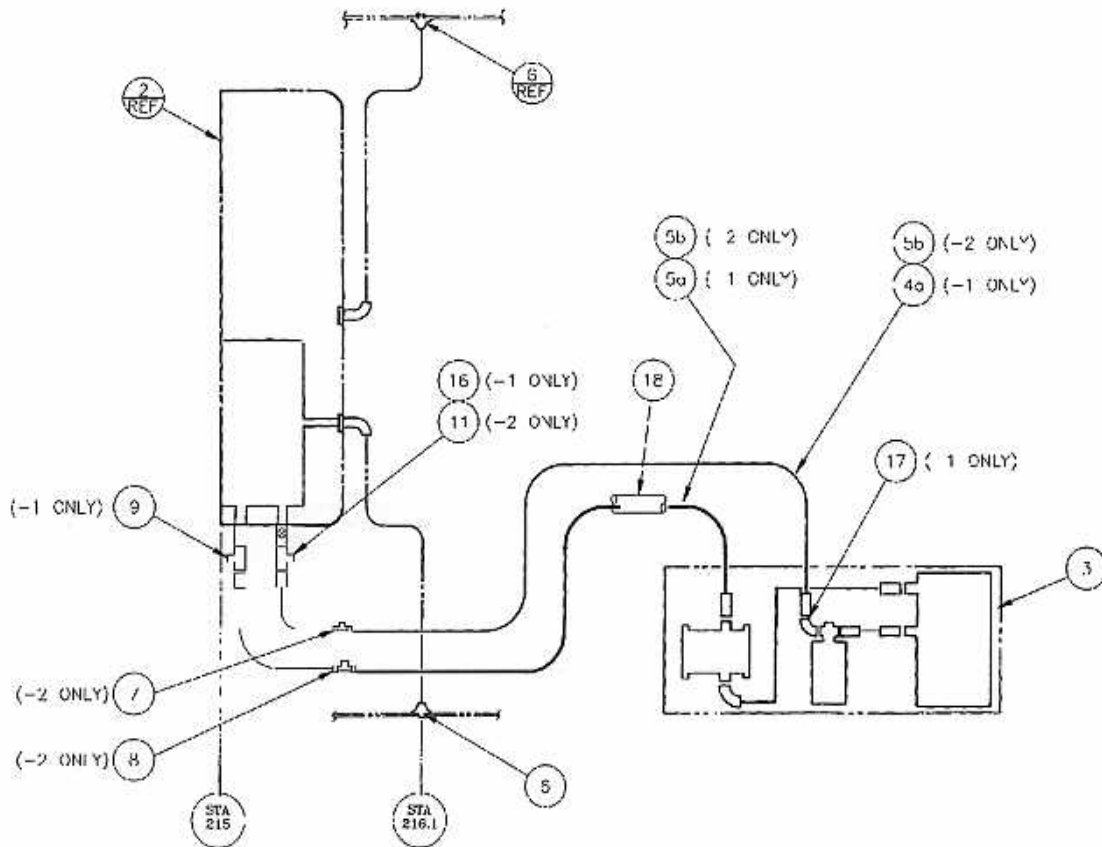

85-02-110-1, -2 Plumbing
 Figure 1

Keith Products, Inc
 Illustrated Parts Catalog

FIG. ITEM	PART NUMBER	NOMENCLATURE	EFFECT	UNITS PER ASSY
1 1	85-02-110-1	Plumbing Installation		RF
	85-02-110-2	Plumbing Installation		
2	85-02-102	Blwr/Evap Mod. Instl.		RF
3	85-02-103	Compressor Pallet Instl		RF
4a	85-02-210-5	Hose Assy.	-1	1
4b	85-02-210-7	Hose Assy.	-2	1
5a	85-02-210-6	Hose Assy.	-1	1
5b	85-02-210-8	Hose Assy.	-2	1
6	82-00-430-8	Drain Instl.		2
7	ES40158-1	Splicer W/R134a SV	-2	RF
8	ES40158-3	Splicer W/R134a SV	-2	RF
9	85-02-302-1	Service Assy-R12	-1	1
16	85-02-302-2	Service Assy-R12	-1	1
11	ES49013-1	Sightglass, Flare	-2	1
17	ES41046-1	Fitting (90°)	-1	1
18	ES02162-3	Tubing Insulation		138 in.

Keith Products, Inc
Illustrated Parts Catalog

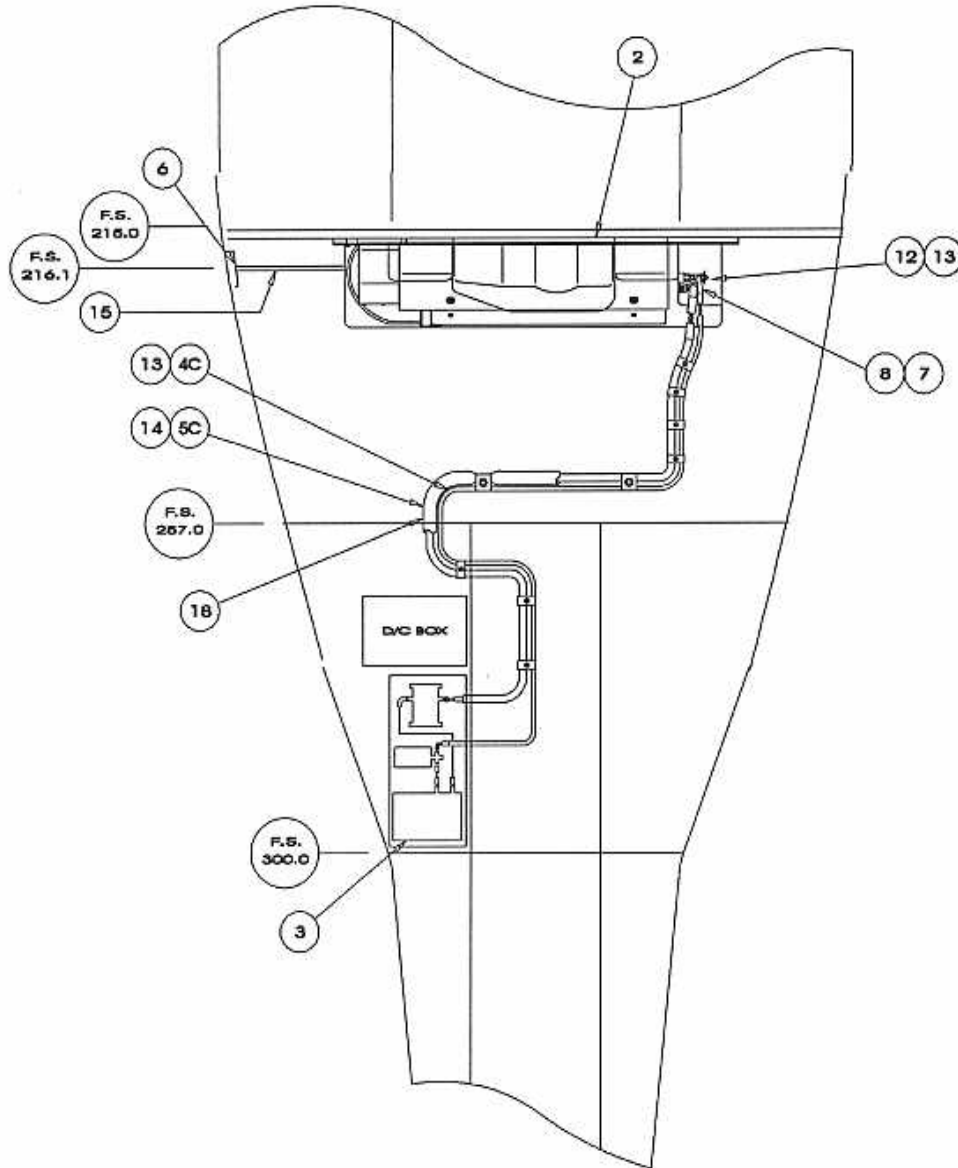

85-02-110-3 Plumbing
Figure 2

Keith Products, Inc
 Illustrated Parts Catalog

FIG. ITEM	PART NUMBER	NOMENCLATURE	EFFECT	UNITS PER ASSY
2 1	85-02-110-3	Plumbing Installation		RF
2	85-02-102	Blwr/Evap Mod. Instl.		RF
3	85-02-103	Compressor Pallet Instl		RF
4c	85-02-210-9	Hose Assy.		1
5c	85-02-210-10	Hose Assy.		1
6	82-00-430-8	Drain Instl.		1
7	ES40158-1	Splicer W/R134a SV		RF
8	ES40158-3	Splicer W/R134a SV		RF
12	ES49014-1	Sightglass, O-Ring		1
13	ES49011-1	O-Ring		3
14	ES49011-3	O-Ring		2
15	ES48012-2	Drain Tube		60 in.
18	ES02162-3	Tubing Insulation		138 in.