

Keith Products, Inc
Air Conditioning System for Cessna 500 Series
Model Nos: 550, S550, 551, 552, 560

<u>Section</u>	<u>Component</u>
21-50-00	System Description
21-50-01	Electrical
21-50-02	Plumbing
21-50-03	Compressor / Condenser Assy
21-50-04	FWD Evaporator
21-50-05	AFT Evaporator

Maintenance Manual
with
Illustrated Parts List

Document No. 82-02-010-1SM

PREPARED BY: Todd Seach

CHECKED BY: Tim Doell

APPROVED: M. FULLER

REPORT DATE: May 15, 1995

APR 25 2007
RELEASE DATE

REVISION: B

REVISION DATE: April 25, 2007

Keith Products, Inc.
Maintenance Manual

LIST OF REVISIONS

Rev	Date	Description	By	Appv
NC	5/15/95	Original Release	TS	MF
A	11/20/00	Added page List of Revisions to maintenance manual. Deleted page Pg 1 Record of Temporary revisions. Modified and updated Title Page, Record of Revisions and List of Effective Pages according to Rev. Changed 21-50-04 Page 1002 I/N 6 was 82-02-441-2, now 82-00-441-2.	JMS	HA
B	4/25/07	Edited P/N on I/N 15 Section 21-50-04 Pg. 1002 WAS JBS276-1 NOW ES61060-2. Edited P/N on I/N 24 Section 21-50-04 Pg. 1005 WAS JBS276-1 NOW ES61060-2. Edited P/N on I/N 15 Section 21-50-05 Pg. 1002 WAS JBS276-1 NOW ES61060-2 Corrected Header on Pg. 1003 Section 21-50-04. Updated List of Service Bulletins. Reason: Product Improvement Per ER3495.	LEO	<i>MAK</i> APR 25 2007 RELEASE DATE

RECORD OF REVISIONS

REV NO.	ISSUE DATE	DATE INSERTED	BY	REV NO.	ISSUE DATE	DATE INSERTED	BY
IR	05-15-95						
A	11-20-00						
B	04-25-07						

LIST OF SERVICE BULLETINS

SERVICE BULLETIN NO.	DATE	SUBJECT	REVISION NO.	DATE INCORP.
SB108	4/06/90	Electrical Ground Problem	B	4/25/07
SB118	6/27/00	Refrigerant Conversion to R134A.	B	4/25/07

LIST OF EFFECTIVE PAGES

<u>CHAPTER</u> <u>SECTION</u> <u>SUBJECT</u>	<u>PAGE</u>	<u>DATE</u>
Title	1	April 25/07
List of Revisions	1	April 25/07
Record of Revisions	1	April 25/07
Service Bulletin List	1	April 25/07
List of Effective Pages	1	April 25/07
	2	April 25/07
Table of Contents	1	May 15/95
	2	May 15/95
Introduction	1	May 15/95
	2	May 15/95
21-50-00	1	May 15/95
	2	May 15/95
	3	May 15/95
21-50-01	1	May 15/95
	101	May 15/95
	102	May 15/95
	103	May 15/95
	1001	May 15/95
	1002	May 15/95
	1003	May 15/95
21-50-02	1	May 15/95
	201	May 15/95
	202	May 15/95
	601	May 15/95
	1001	May 15/95
	1002	May 15/95
21-50-03	1	May 15/95
	101	May 15/95
	102	May 15/95
	201	May 15/95
	202	May 15/95
	1001	May 15/95
	1002	May 15/95

15/95 LIST OF EFFECTIVE PAGES

<u>CHAPTER</u> <u>SECTION</u> <u>SUBJECT</u>	<u>PAGE</u>	<u>DATE</u>
21-50-04	1	May 15/95
	101	May 15/95
	201	May 15/95
	1001	May 15/95
	1002	April 25/07
	1003	April 25/07
	1004	May 15/95
	1005	April 25/07
	1006	May 15/95
	21-50-05	1
101		May 15/95
201		May 15/95
1001		May 15/95
1002		April 25/07
1003		May 15/95

TABLE OF CONTENTS

<u>Subject</u>	<u>Chapter Section Subject</u>	<u>Page</u>
<u>INTRODUCTION</u>		1
<u>AIR CONDITIONING SYSTEM</u>	21-50-00	
System Description		1
<u>ELECTRICAL</u>	21-50-01	
Description & Operation		1
Troubleshooting		101
Illustrated Parts List		1001
<u>PLUMBING</u>	21-50-02	
Description & Operation		1
Maintenance Practices		201
Inspection/Check		601
Illustrated Parts List		1001
<u>COMPRESSOR/CONDENSER ASSEMBLY</u>	21-50-03	
Description & Operation		1
Troubleshooting		101
Maintenance Practices		201
Illustrated Parts List		1001

TABLE OF CONTENTS

<u>Subject</u>	<u>Chapter Section Subject</u>	<u>Page</u>
<u>FWD EVAPORATOR ASSY</u>	21-50-04	
Description & Operation		1
Troubleshooting		101
Maintenance Practices		201
Illustrated Parts List		1001
<u>AFT EVAPORATOR ASSY</u>	21-50-05	
Description & Operation		1
Troubleshooting		101
Maintenance Practices		201
Illustrated Parts List		1001

INTRODUCTION

1. PURPOSE

The purpose of this Maintenance Manual is to provide detailed instructions for the troubleshooting, checking and maintaining of the Keith Products, Inc. air conditioning system for the Cessna Citation aircraft, models 550 S550, 551, 552, 560.

The Keith Products air conditioning system is installed in accordance with STC SA2698SW.

2. SCOPE

The scope of the service and maintenance manual provides the maintenance technician with detailed information covering:

- Overall system level description and theory of operation.
- Component level description and theory of operation.
- Component checking and troubleshooting procedures.
- Maintenance practices to keep the environmental control system operating at its maximum efficiency.
- The identification of special equipment to accomplish the specific tasks.
- An Illustrated Parts List (IPL) covering the breakdown of each major component of the air conditioning system, including part number and relevant illustrations.

3. ARRANGEMENT

This Maintenance Manual is arranged in accordance with Air Transport Association (ATA) Specification 100 and includes an Illustrated Parts List.

4. GLOSSARY

Nonstandard abbreviations and symbols used in the Maintenance Manual are described below.

Keith Products, Inc.
Maintenance Manual

Abbreviations:

A/C	-	Air Conditioning
A/R	-	As Required
Assy	-	Assembly
Comm. Avail.	-	Commercially Available
Evap	-	Evaporator
FWD	-	Forward
Gnd	-	Ground
GPU	-	Ground Power Unit
IPL	-	Illustrated Parts List
STC	-	Supplemental Type Certificate
SW	-	Switch
VDC	-	Volts Direct Current

AIR CONDITIONING SYSTEM - SYSTEM DESCRIPTION

1. GENERAL

The air conditioning system for the Cessna 500 series aircraft consists of a refrigerant R134a vapor cycle cooling system. This system allows the co-pilot to control cooling for a comfortable aircraft cabin. Figure 1 shows a general arrangement of the air conditioning system.

The co-pilot's control panel contains the cooling system ON/OFF/FAN switch, the FWD fan LOW/HIGH switch, the AFT fan OFF/LOW/HIGH and a blue A/C system ON indicator.

2. COOLING SYSTEM

The cooling or air conditioning system, as designed and manufactured by Keith Products for the Cessna 500 Series aircraft, is a vapor cycle type cooling system using refrigerant R134a. The system is electrically operated using the aircraft 28 VDC electrical system and is operable in all normal flight modes up to 18,000 feet MSL. Air conditioning may be operated with ground external power or the aircraft electrical system providing 28 vDC to the non-essential buss.

The major components of the system are the compressor/condenser assembly with blower, and two evaporator/cabin blower units. Refrigerant plumbing and electrical systems connect the major component to provide a closed loop system.

The compressor/condenser assembly is mounted either forward of the rear baggage door; or in the baggage compartment. The compressor drive and condenser fan drive are both driven by a common, double shafted motor which turns at approximately 4500 RPM. The compressor is belt driven from the shortest shaft while the condenser fan is attached directly to the longer motor shaft. Condenser cooling air (ambient air) is drawn in through a cutout in either underside of the engine pylon or the right side of the fuselage of the aircraft by the condenser fan. The air passes over the compressor and drive motor to provide cooling airflow for those components prior to passing through the condenser coil to remove heat from the system. After passing through the condenser coil, the air is exhausted to the outside through an exhaust duct located either on the underside of the fuselage; or through a cutout on the left side of the aircraft. The compressor takes low pressure refrigerant gas and compresses it to a higher pressure and temperature.

An evaporator/blower unit is located in the aft cabin at the end of the recessed isle (at floor level) within the aircraft interior. It provides cooling airflow for the cabin area of the interior. A forward evaporator is located at the cockpit floor and provides cooling airflow to the flight crew through a floor mounted air outlet or through dedicated ducting at the pilot's and co-pilot's control stick. Both evaporators are of a design wherein the cabin air is drawn into the evaporator coil and the fan then delivers the conditioned air to the cabin. This recirculating system continues to dry and cool the air each time it passes through the evaporator. Moisture removed from the air by the cold coil (condensate) is collected within the evaporator housing and is forced overboard. Each evaporator is equipped with a thermal expansion valve which regulates the amount of refrigerant entering the coil to provide optimum cooling effect. The evaporator blowers can be operated in the "FAN" position to re-irculate cabin air without cooling. Each blower is operated from an independent fan speed control.

The plumbing which connects the compressor, condenser and the evaporators, consists of rubber based hoses with a nylon barrier. The fittings are permanently swaged onto the hoses. All fittings are "o-ring" type connections with sealant on the fitting mating surfaces to prevent refrigerant leaks. Two R134a service valves are located near the compressor/condenser pallet assembly. They are sized differently to avoid incorrect cross-connecting when gaining access to the plumbing for system recharging.

On the ground, the electrical system allows operation of the air conditioning system from either aircraft power or from an active GPU prior to engine start. System safety features include electrical interlocking and load shedding. In flight, the air conditioning system can be operated from the aircraft electrical system only with both generators on line. Loss of either generator will automatically shed the air conditioning system electrical loads except for the minimal loads of the evaporator fans.

The entire air conditioning refrigerant loop is protected against over pressure conditions by two separate safety devices. The first device is a binary high/low pressure switch that activates in the event of an overpressure and is on the compressor discharge port. This switch will open at approximately 350 PSIG and will interrupt power to the compressor control circuit. This in turn will de-energize the compressor motor relay and remove power to the compressor motor. The refrigerant system pressures will then drop. The switch will also interrupt power to the compressor control circuit under low pressure conditions. The second overpressure safety device is a fuse plug which will vent the system refrigerant safely overboard in the event of a system pressure in excess of 425 PSIG. It is located on the receiver/drier.

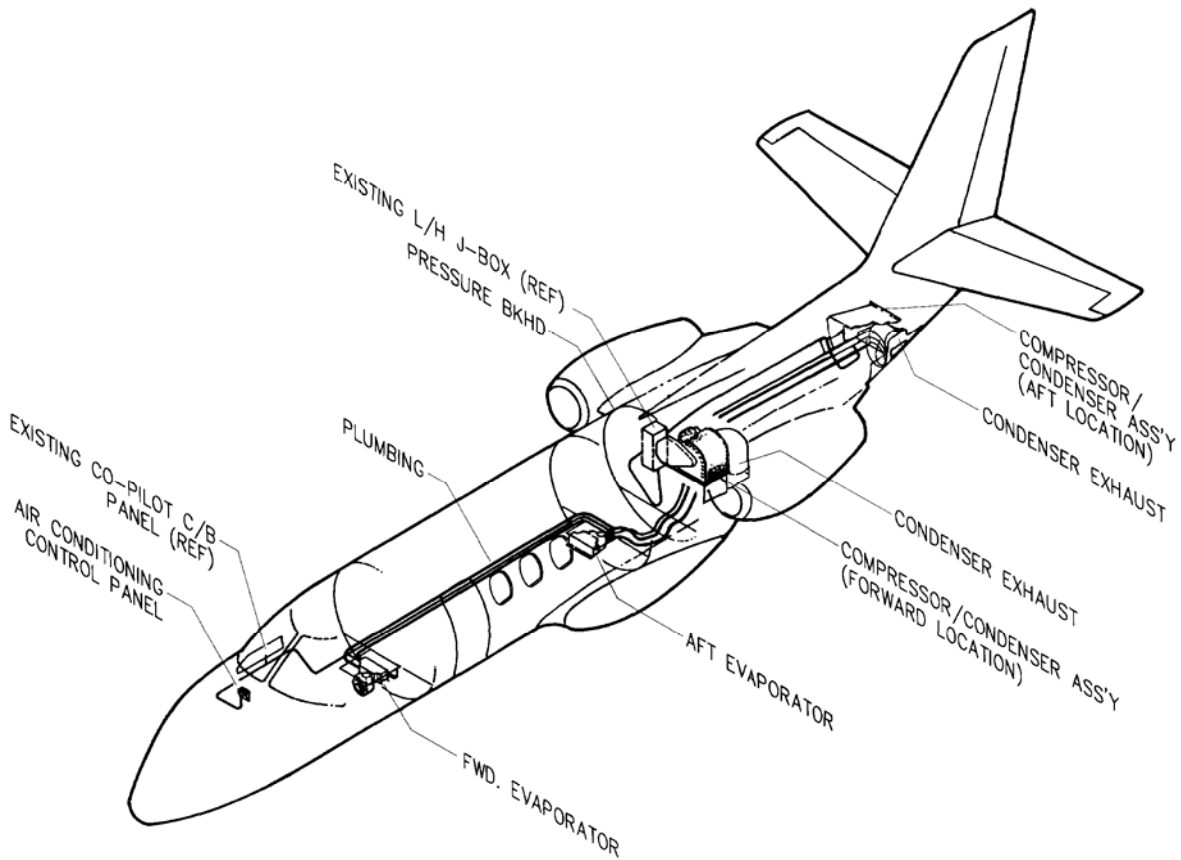

Figure 1. Air Conditioning System General Arrangement

ELECTRICAL

DESCRIPTION AND OPERATION

1. GENERAL

The air conditioning system consists of one high energy compressor/condenser drive motor and two centrifugal evaporator blowers (Fwd) and (Aft). The system is controlled by a mode switch with Air Conditioning Off and Fan Only position. Each evaporator has a high and low position switch. A blue indicator light will illuminate whenever the compressor/condenser is selected. The system incorporates a binary pressure switch to sense an over pressure or under pressure condition in the system.

The air conditioning system is controlled by a Logic Card which monitors generator, GPU and battery inputs to ensure operation or shedding of the system if a fault exists.

The system is protected by a 15 amp control and blower breaker and a 100 amp breaker for the compressor/condenser drive motor.

This section of the maintenance manual describes the electrical system and presents electrical troubleshooting procedures. An Illustrated Parts List is included in Figure 1.

2. LOAD/SHED DESCRIPTION

The system incorporates a logic control PC card that enables the system to operate or be shed under various conditions. The table below shows operation under various conditions.

<u>CONDITIONS</u>	<u>EVAP FANS</u>	<u>COMP/COND</u>
Gnd Power Cart/On	On	On
Gnd Power Cart Connected/Off	On	Off
Battery Only	On	Off
One Generator on Ground	On	On
Both Generators on Ground	On	On
Refrigerant Over/Under Pressure	On	Off
One Generator in Flight	On	Off
Both Generators in Flight	On	On

TROUBLESHOOTING

1. GENERAL

The following procedures are used for troubleshooting the electrical system and the electrical interfaces with the other assemblies of the air conditioning system.

2. TOOLS AND EQUIPMENT

Designation	Ref. No.	Qty	Remarks
Service Pressure Gauge	Comm. Avail.	1	None
Multi-meter	Comm. Avail.	1	None
28vdc Source		A/R	None

3. ELECTRICAL TROUBLESHOOTING PROCEDURES (REF. IPL Fig. 1)

NOTE: Always attach a service gauge set to system prior to beginning trouble shooting to insure proper refrigerant charge is present.

A. Air Condition Selected, Compressor/Condenser Motor Does Not Turn.

1. Connect service pressure gauge to service ports located near compressor/condenser pallet.
2. Connect ground power to aircraft.
3. Select air conditioning system to ON.
4. Check that load shed start conditions in the Description and Operation paragraph are met.
5. Check for power at comp/cond relay located on the pallet assembly, if not present check 100A circuit breaker (4). Replace if necessary.
6. Check continuity of pressure switch (Ref. 21-50-03 IPL Fig. 1, item 11). If no continuity and gauge set reads adequate pressure, replace pressure switch. Switch can be removed without discharge of refrigeration. Back switch off in a counter clockwise direction. Re-install in reverse order. Lubricate o-ring in switch per 21-50-02 page 202.

7. Check for power at motor . If power is present, proceed to step 8. If power is not present on either pin and load/shed conditions of step 4 are met, check power on the load shed unit at connector Pin 1. If power is present, system problem exists in load shed system start unit. If power is not present, check 15 amp CB (3) and mode switch (26).
 8. Fault is isolated to compressor/condenser motor. Unit should be replaced.
 9. Select air conditioning OFF, remove electrical power, disconnect service gauge when troubleshooting is complete.
- B. FWD Evaporator Blower will not operate in high or low speed.
1. Connect ground power to aircraft.
 2. Select air conditioning system to ON.
 3. Check if power and ground present at fan wire splices and GND terminal strip. If power and ground are present, blower motor (Ref. 21-50-04 IPL Fig.1, item 15, or IPL Fig. 2, item 24) has failed.
 4. Select air conditioning OFF, remove electrical power.
 5. Remove blower assy from aircraft. Remove the four screws attaching the motor to the housing. Using a 1/8 allen wrench remove blower wheel (use extreme care not to bend blower wheel). Cut power wires at splice and remove Gnd wire from GND terminal. Install new motor in reverse order.
- C. FWD Evaporator Blower will not operate in the low speed setting.
1. Connect ground power to aircraft.
 2. Select air conditioning system to ON.
 3. Check if power is present at wire EVAP-FL (at splice). If power is present, the low speed resistor (Ref. 21-50-04 IPL Fig. 1, item 17, or IPL Fig. 2, item 23) has failed.
 4. Select air conditioning OFF, remove electrical power.
 5. Remove blower assembly and using a #21 drill remove the two rivets securing the resistor. Cut the wires at the splice and remove GND wire from GND terminal. Install new resistor in reverse order.
- D. AFT Evaporator Blower will not operate in high or low speed.
1. Connect ground power to aircraft.
 2. Select air conditioning system to ON.
 3. Check if power and ground present at fan wire splices and GND terminal strip. If power and ground are present, blower motor (Ref. 21-50-05 IPL Fig.1, item 15) has failed.
 4. Select air conditioning OFF, remove electrical power.

5. Remove blower assy from aircraft. Remove the four screws attaching the motor to the housing. Using a 1/8 allen wrench remove blower wheel (use extreme care not to bend blower wheel). Cut power wires at splice and remove Gnd wire from GND terminal. Install new motor in reverse order.
- E. AFT Evaporator Blower will not operate in the low speed setting.
1. Connect ground power to aircraft.
 2. Select air conditioning system to ON.
 3. Check if power is present at wire EVAP-AL (at splice). If power is present, the low speed resistor (Ref. 21-50-05 IPL Fig. 1, item 9) has failed.
 4. Select air conditioning OFF, remove electrical power.
 5. Remove blower assembly and using a #21 drill remove the two rivets securing the resistor. Cut the wires at the splice and remove GND wire from GND terminal. Install new resistor in reverse order.

Keith Products, Inc. Maintenance Manual

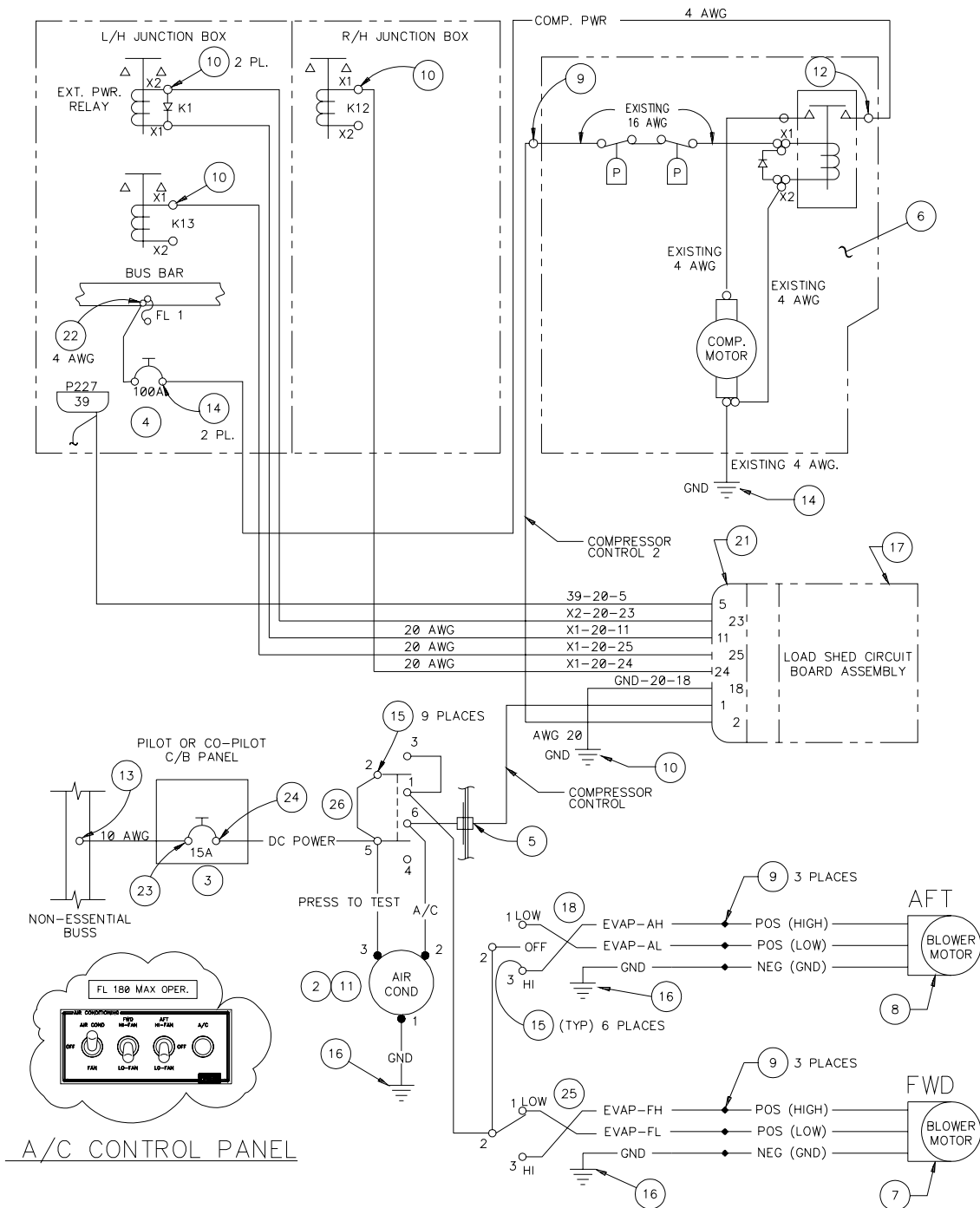

Figure 1. Electrical System

FIG. ITEM	PART NUMBER	NOMENCLATURE	EFFECT	UNITS PER ASSY
1 1	82-02-106	Electrical Installation		RF
2	JBS11001-1	Light (Blue)		1
3	MS3320-15	Circuit Breaker		1
4	MS25361-100	Circuit Breaker		1
5	ES32036-1	Grommet		1
6	JBS5005-1	Compressor/Condenser		1 ref
7	JBS2030-3	FWD Evaporator		1 ref
8	JBS2048-3	AFT Evaporator		1 ref
9	MS25181-2	Butt Connector		7
10	MS25036-101	Terminal		5
11	ES50162-1	Lamp		1
12	MS25036-125	Terminal		1
13	MS25036-157	Terminal		1
14	MS25036-123	Terminal		1

Air Conditioning System - Electrical System
IPL FIGURE 1

FIG. ITEM	PART NUMBER	NOMENCLATURE	EFFECT	UNITS PER ASSY
15	MS25036-106	Terminal		15
16	MS25036-108	Terminal		3
17	84-00-07-8	Load Shed Assy		1
18	ES57016-3	Switch		1
21	ES53010-3	Connector		1
22	MS25036-124	Terminal		1
23	MS25036-156	Terminal		1
24	ES55077-2	Terminal		1
25	ES57016-6	Switch		1
26	ES57016-5	Switch		1

Air Conditioning System - Electrical System
IPL FIGURE 1

PLUMBING

DESCRIPTION AND OPERATION

1. GENERAL

The plumbing system consists of a flexible nylon lined refrigerant hose with permanent swaged on fittings. All connections are tube O-ring type with sealant on the fitting mating surfaces to ensure leak free operation. Hose, O-ring material, and sealant are specially designed to work with refrigerant R134a and polyol ester oils. Two service valves are located near the compressor/condenser assembly. They are sized differently to avoid incorrect cross-connecting when gaining access to the plumbing for system recharging. A receiver/drier is installed downstream of the condenser to remove moisture from the liquid refrigerant. A binary pressure switch monitors the refrigerant gas pressure. This switch will open at a condenser over pressure of 350 psi and under pressured conditions of 30 psi. This will interrupt the power to the compressor control circuit and stop the compressor.

This section of the maintenance manual discusses checks and maintenance practices used for the plumbing portion of the air conditioning system. An Illustrated Parts List is included in Figure 1.

MAINTENANCE PRACTICES

1. GENERAL

The following procedures are used to perform typical maintenance on the air conditioning system plumbing.

2. TOOLS AND EQUIPMENT

Designation	Ref. No.	Qty	Remarks
R134a Compatible Hose Swaging Kit	Available from Keith Products	1	None
Sharp Knife	Comm. Avail.	1	None
Impact Wrench	Comm. Avail.	1	None
Polyol Ester Oil	Comm. Avail.	A/R	Viscosity Grade 68
Sealant	ES49000-1	A/R	None

3. PLUMBING MAINTENANCE PROCEDURES (REF. IPL Fig. 1)

A. Hose or Fitting Replacement

NOTE: If it is found that a hose or fitting has a leak, it will be necessary to replace the entire hose assembly. Follow the Hose Swaging Instruction below:

1. Hose should only be cut with a sharp knife. (**Note:** Use of serrated blades or saws to cut hose will leave particles that can contaminate system.)
2. Insert the proper size die in the swaging tool.
3. Insert fitting in swaging tool so that it is centered in the die and hand tighten.
4. Insert hose in fitting until it bottoms (**Note:** Indicating hole is in base of fitting).
5. Using impact wrench, tighten nut until die housings contact. (**Note:** It is important to keep hose pushed into fitting while swaging).
6. Reverse impact and back off nut until housing contacts rubber stops.

B. Connection to Components - O-Ring Replacement

1. Place the appropriate o-ring (REF. IPL Fig. 1) over the tube "O" end of the fitting.
2. Lubricate o-ring with polyol ester oil or sealant prior to assembly.
3. Apply sealant to all fitting mating surfaces prior to assembly.

C. Receiver/Drier Replacement

1. Replace receiver/drier whenever the compressor is replaced or when the air conditioning system plumbing is left open to the atmosphere.

INSPECTION/CHECK

1. GENERAL

The following procedures are used for checking and inspecting the air conditioning system plumbing.

2. TOOLS AND EQUIPMENT

Designation	Ref. No.	Qty	Remarks
Electronic R134a Refrigerant Leak Detector	Comm. Avail.	1	None

3. PLUMBING CHECK PROCEDURES (REF. IPL Fig. 1)

A Plumbing Installation Preventive Maintenance Check

NOTE: All O-rings should be lubricated with polyol ester oil or sealant applied to all fittings mating surfaces before assembly.

1. Check that all hoses are properly supported and do not chafe. Check that all clamps remain secure and that the hose and fitting are well supported at connections with fixed units such as evaporator, condenser etc. to prevent fatigue cracking in tubing headers or fittings.

B. Plumbing System Refrigerant Leak Check

1. Connect service pressure gauge set to service ports, located near the compressor/condenser assembly.
2. Check that the gauges are reading the proper static pressure. Both gauges should read approximately 55 psig @ standard temperature (59°F) with a properly charged system when the system is not operating.
3. Using leak detector, check entire plumbing system including hose fittings and coil assemblies for leaks. There shall be no leaks. Repair or replace leaking component per the appropriate maintenance manual section and its IPL.

Keith Products, Inc.
Maintenance Manual

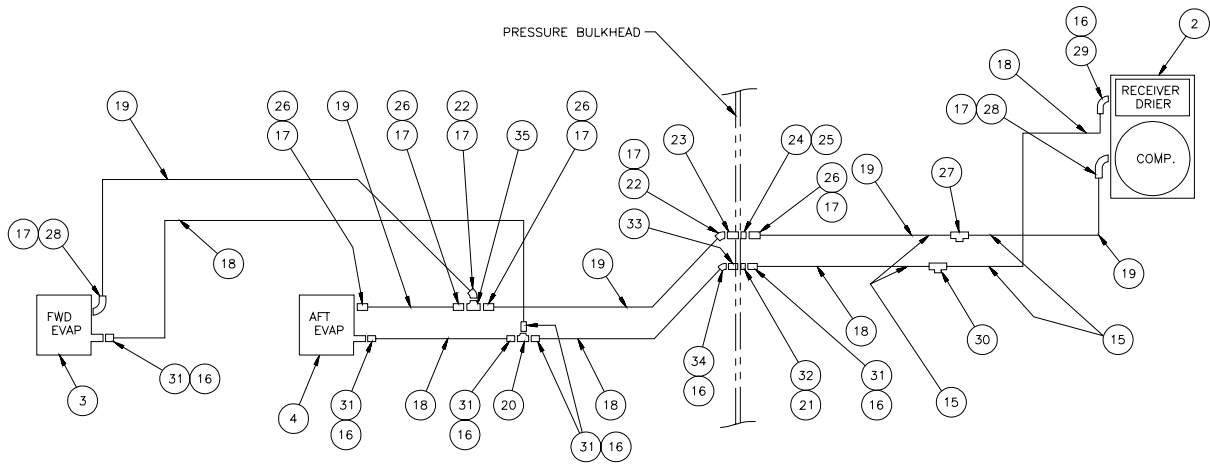

Figure 1. Plumbing System

Keith Products, Inc.
Maintenance Manual

FIG. ITEM	PART NUMBER	NOMENCLATURE	EFFECT	UNITS PER ASSY
1 1	82-02-105-5,-6	Plumbing Installation		RF
2	JBS5005-1	Compressor/Condenser		1 ref
3	JBS2030-3	FWD Evaporator		1 ref
4	JBS2048-3	AFT Evaporator		1 ref
-	88-00-431-1	Drain Instl		1
-	MS21919WDG 12	Clamp		20
-	MS20365-1032	Nut		40
-	AN960-10	Washer		9
-	NAS221-10	Screw		10
-	MS21919WDG 9	Clamp		20
-	ES06022-1	Insulation Tape		180 in
-	ES02162-2	Insulation Tubing		288 in
-	MS3367-7	Cable Tie		80
15	JBS10-64	Placard		4
16	ES49011-1	O-ring		8
17	ES49011-3	O-ring		8
18	ES48149-1	Hose		500 in
19	ES48149-3	Hose		500 in
20	ES41061-1	Adapter Tee		1
21	MS28775-114	Bulkhead O-ring		1
22	ES40150-3	Fitting		2
23	JBS6009-3	Bulkhead Fitting		1
24	AN6289-10D	Nut		1
25	MS28775-211	Bulkhead O-ring		1
26	ES40149-3	Straight Fitting		4
27	ES40158-3	Service Valve		1
28	ES40151-3	90° Fitting		2
29	ES40151-1	90° Fitting		1
30	ES40158-1	Service Valve		1
31	ES40149-1	Straight Fitting		6
32	ES49016-1	BKHD Fitting Nut		1
33	JBS6009-1	Bulkhead Fitting		1
34	ES40150-1	45° Fitting		1
35	ES41061-2	Tee		1

Air Conditioning System - Plumbing System
IPL FIGURE 1
COMPRESSOR/CONDENSER ASSEMBLY

DESCRIPTION AND OPERATION

1. GENERAL

The compressor/condenser assembly is located either forward of the rear baggage door; or in the baggage compartment. This unit consists of a drive motor, compressor, condenser fan assembly, condenser coil, and pressure switch. The drive motor via a multi V flat belt, turns the compressor which compresses the refrigerant gas at which it will condense at ambient temperatures. This gas is directed to the condenser where its heat is removed by air flow from the condenser fan. The fan is attached to the long shaft of the drive motor. This air is exhausted overboard via exhaust duct located either on the bottom of the aircraft or on the left side of the aircraft. The condenser condenses the refrigerant gas to a liquid. This liquid is collected by the receiver/drier where moisture is removed. A binary pressure switch monitors the refrigerant gas pressure. This switch will open at a condenser over pressure of 350 psi and under pressure conditions of 30 psi. This will interrupt the signal to the control board and stop the compressor/condenser unit.

This section of the maintenance manual discusses troubleshooting and maintenance practices used for the compressor/condenser assembly portion of the air conditioning system. An Illustrated Parts List is included in Figure 1.

TROUBLESHOOTING

1. GENERAL

The following procedures are used for troubleshooting the comp/cond assembly.

2. TOOLS AND EQUIPMENT

Designation	Ref. No.	Qty	Remarks
Service Pressure Gauge	Comm. Avail.	1	None
28vdc Source		A/R	None

3. COMP/COND TROUBLESHOOTING PROCEDURES (REF. IPL Fig. 1)

With the air conditioning system operating, do any of the following conditions occur:

NOTE: Always attach a service gauge set to system prior to being trouble shooting to insure proper refrigerant charge is present.

<u>Trouble</u>	<u>Probable Cause</u>	<u>Correction</u>
1. Unusually high suction pressure with low discharge pressure.	Internal problem with compressor body.	Repair leak or replace compressor.
2. Unusually low suction and discharge pressure.	System or compressor Leak.	(a) Inspect/replace exhaust duct. (b) Discharge refrigerant until only occasional bubbles are present in sight glass.
3. High compressor discharge pressure.	(a) Air exhaust duct collapsed or restricted. (b) Refrigerant overcharge.	Replace compressor.
4. Rough running.	Internal compressor problem. Replace compressor.	

Keith Products, Inc.
Maintenance Manual

<u>Trouble</u>	<u>Probable Cause</u>	<u>Correction</u>
5. Low air flow across condenser coil.	Dirty condenser coil.	Clean condenser coil.

MAINTENANCE PRACTICES

1. GENERAL

The following procedures are used to perform typical maintenance on the compressor/condenser assembly.

2. TOOLS AND EQUIPMENT

Designation	Ref. No.	Qty	Remarks
Feeler Gage	Comm. Avail.	1	None
Oil Dipstick	Make from metal wire.	1	See Fig. 201.
Coil Cleaner	Comm. Avail.	A/R	Non Acid Based
Polyol Ester Oil	Comm. Avail.	A/R	Viscosity Grade 68

3. COMPRESSOR/CONDENSER MAINTENANCE PROCEDURES (REF. IPL Fig. 1)

A. Compressor Drive Belt Adjustment

1. Adjust belt for moderate tension and then rotate large pulley through 2 revolutions.
2. Tension belt to deflect 0.16 inch with a 2 - 3 lb. force applied at midspan location.
3. Rotate belt 2 revolutions, retention as required.

B. Compressor Pulley Installation; Pulley - Bearing Carrier Air Gap Check

NOTE: This procedure should be accomplished when installing the pulley on a new compressor to ensure proper pulley installation.

1. Add combination of shims from nut and shim kit (item 2) to ensure air gap between pulley and bearing carrier. Use .005 shim with stack.
2. Temporarily install pulley to shaft holding against shims.
3. Measure air gap between pulley and bearing carrier flange with feeler gauge, remove pulley.
4. Remove shim material .005 inch more than measured air gap.
5. Install pulley and woodruff key.
6. Install locknut from kit; torque to 25-30 ft lbs.

C. Condenser Coil Cleaning Procedure

1. Use vacuum cleaner to remove large debris from upstream and downstream coil faces.
2. Spray coil cleaner on both coil faces. Wash off with water.
3. Allow condenser coil to dry thoroughly prior to additional maintenance.

D. Compressor Oil Level Check

NOTE: It is not necessary to check the compressor oil level during routine maintenance. It only needs to be checked when a system component is replaced or when incorrect oil level is suspected. Use only polyol ester oil viscosity grade 68.

1. Operate air conditioning system for 10 minutes. This will collect as much oil as possible in the compressor.
2. Discharge air conditioning system and remove compressor from aircraft.
3. Place compressor on table such that the oil fill plug is up.
4. Remove oil fill plug.
5. Insert dipstick into oil fill port.
6. Check that the oil level is 5 fluid ounces (at the 5th increment). Add or subtract oil in 1 fluid ounce increments until 5 fluid ounces is obtained.
7. Clean oil fill port area and install oil fill plug. Torque plug to 6 - 9 ft-lbs.

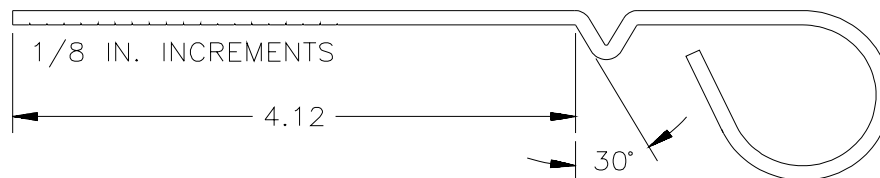

Figure 201. Make Dipstick as Shown Above.

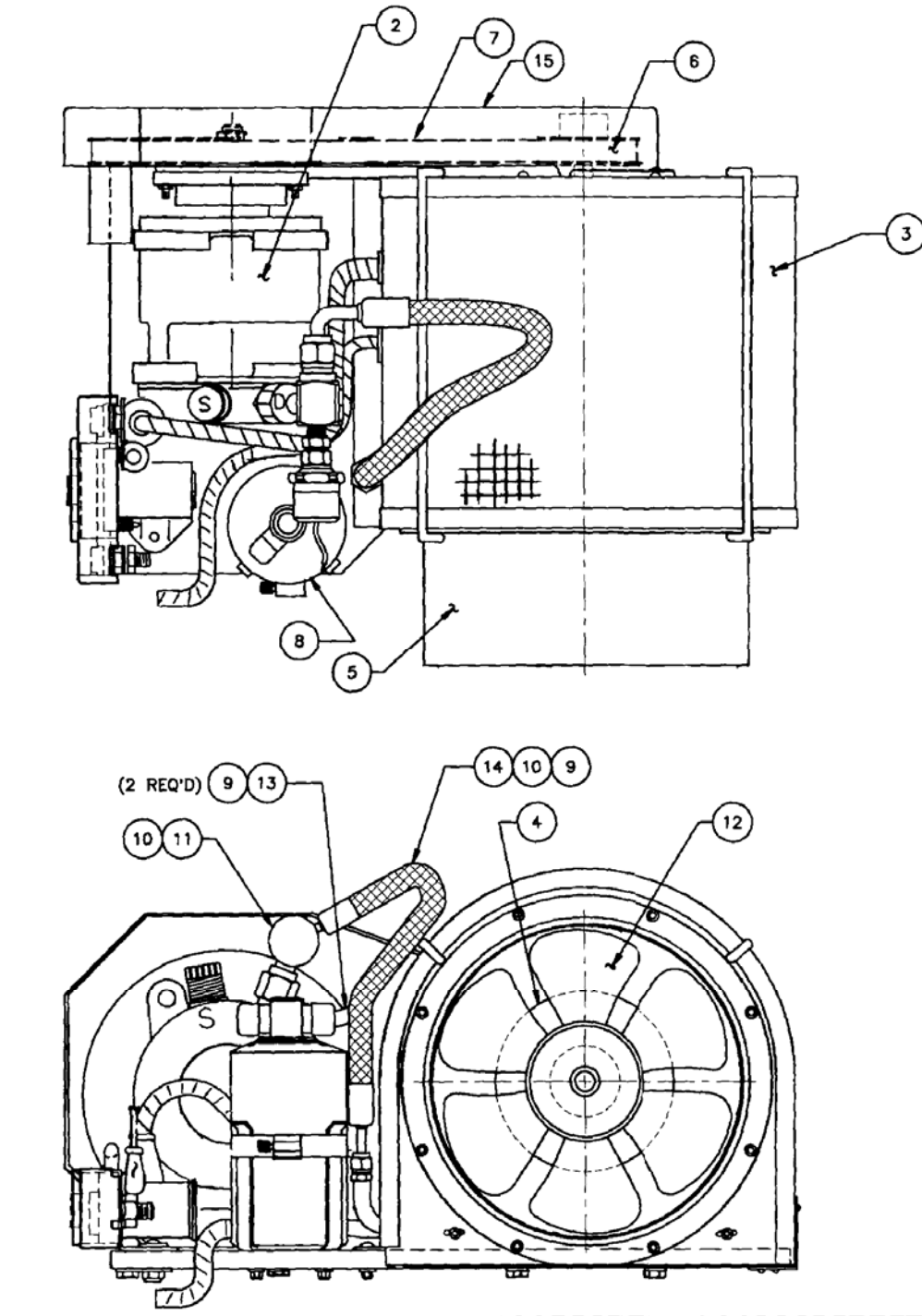

Figure 1. Compressor/Condenser Assembly

Keith Products, Inc.
Maintenance Manual

FIG. ITEM	PART NUMBER	NOMENCLATURE	EFFECT	UNITS PER ASSY
1 1	JBS5005-1	Compressor Condenser		RF
2	JBS221-1 ES20145-1	Compressor Assy Shim Accessory Kit		1
3	JBS412-17	Condenser Coil		1
4	ES61108-1	Motor		1
5	JBS567-2	Fan Duct		1
6	JBS14002-4	Pulley, Ribbed Drive		1
7	ES20040-4	Belt, Pulley "V"		1
8	ES43030-2	Receiver Drier Bottle		1
9	ES49011-1	O-ring		3
10	ES49011-2	O-ring		2
11	JBS2020-5	Pressure Switch		1
12	JBS2024-1	Fan Assy		1
13	JBS460-2	Tube Assy		1
14	JBS461-5	Hose Assy		1
15	JBS611-1	Belt Guard Assy		1

Air Conditioning System - Compressor/Condenser Assembly
IPL FIGURE 1

FWD EVAPORATOR ASSEMBLY

DESCRIPTION AND OPERATION

1. GENERAL

The FWD evaporator assembly for the Cessna 500 series is located at the cockpit floor and provides cooling airflow to the flight crew through a floor mounted air outlet or through dedicated ducting at the pilot's and co-pilot's control stick. The evaporator assembly includes an evaporator coil, blower with motor, expansion valve and air outlet ducting.

This section of the maintenance manual discusses troubleshooting and maintenance practices used for the FWD evaporator assembly portion of the air conditioning system. Additional troubleshooting and testing procedures for the evaporator blower is contained in 21-50-01, page 101. An Illustrated Parts List is included in Figures 1 and 2.

TROUBLESHOOTING

1. GENERAL

The following procedures are used for troubleshooting the fwd evaporator assembly portion of the air conditioning system.

2. TOOLS AND EQUIPMENT

Designation	Ref. No.	Qty	Remarks
Service Pressure Gauge	Comm. Avail.	1	None
28vdc Source		A/R	None

3. EVAPORATOR TROUBLESHOOTING PROCEDURES (REF. IPL Fig. 1 & 2)

NOTE: Always attach a service gauge set to system prior to being trouble shooting to insure proper refrigerant charge is present.

A. Water is Being Blown from Air Outlets.

1. Operate GPU and apply 28 vdc electrical power.
2. Select air conditioning system to ON.
3. Check evaporator drain for condensate runoff.
4. If no runoff, clear drain of blockage or verify that routing is in a down hill orientation.
5. Select air conditioning OFF, remove electrical power.

B. No Cooling at Evaporator.

1. Connect service pressure gauge to service ports located near compressor/condenser assembly.
2. Operate GPU and apply 28 vdc electrical power.
3. Select air conditioning system to ON.
4. Check evaporator for proper cooling. If cooling not sufficient, check refrigerant level to ensure that system is correctly charged, this can be confirmed by a clear sight glass (no bubbles) on the top of the receiver dryer. If bubbles are present, add refrigerant till sight glass just clears.
5. If system is correctly charged, replace expansion valve per Maintenance Practices procedure.

MAINTENANCE PRACTICES

1. GENERAL

The following procedures are used to perform typical maintenance on the evaporator assembly.

2. TOOLS AND EQUIPMENT

Designation	Ref. No.	Qty	Remarks
Sealant	ES49000-1	A/R	None
Polyol Ester Oil	Comm. Avail.	A/R	Viscosity Grade 68
Vacuum Cleaner	Comm. Avail.	1	None
Coil Cleaner	Comm. Avail.	A/R	Non-acid based

3. EVAPORATOR MAINTENANCE PROCEDURES (REF. IPL Fig. 1 & 2)

A. Expansion Valve Replacement

1. Discharge system in accordance with recovery equipment's instructions.
2. Disconnect liquid line from inlet of expansion valve, and cap. Remove the thermal sense bulb from its clamp located on the suction tube of the evaporator and carefully remove insulation covering bulb.
3. Disconnect the fitting that connects the valve to the coil and plug coil fitting.
4. Install new expansion valve and o-ring in the reverse order.
5. Lubricate o-ring with polyol ester oil or apply sealant to fitting mating surfaces prior to assembly.
6. Install the thermal sense bulb such that it makes contact with the suction tube along its entire length. Insulate the bulb thoroughly with insulation.

B. Evaporator Coil Cleaning Procedure

1. Use vacuum cleaner to remove large debris from upstream and downstream coil faces.
2. Spray coil cleaner on both coil faces. Wash off with water.
3. Allow coil to dry thoroughly prior to additional maintenance.

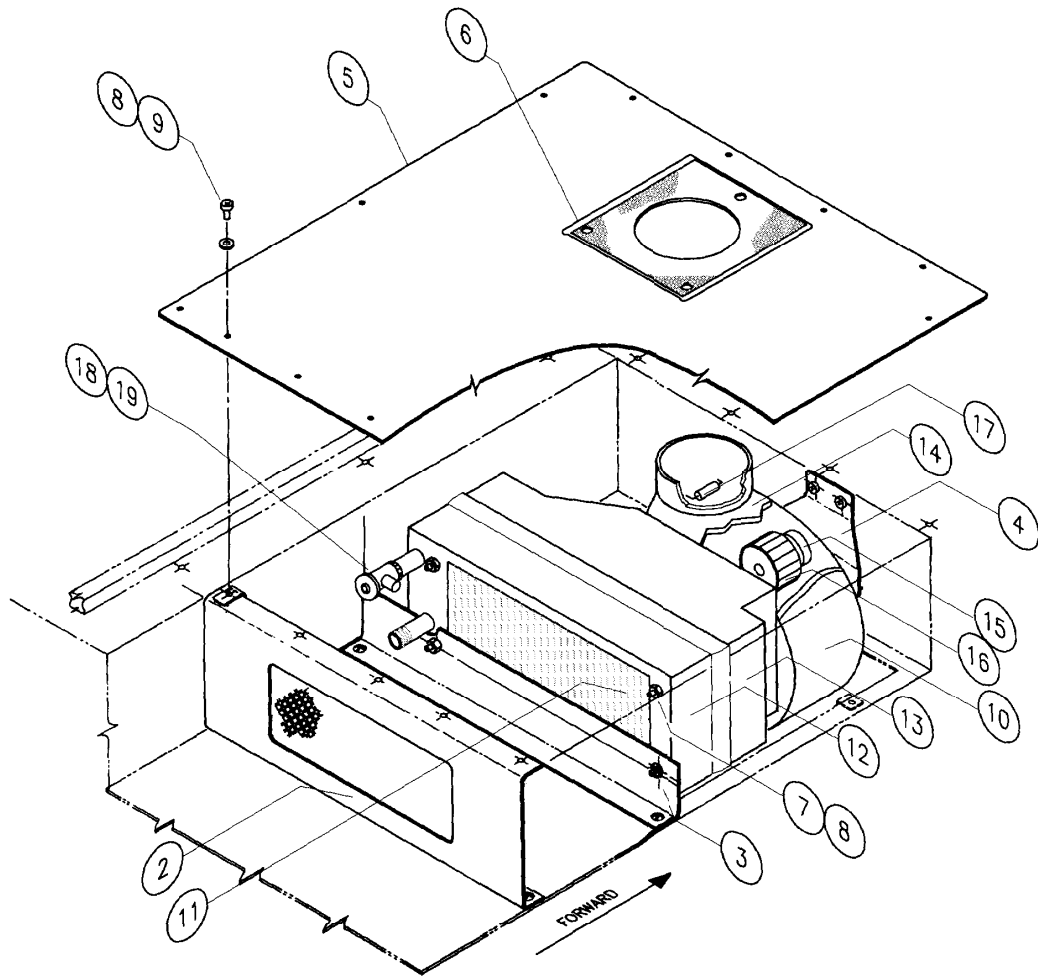

Figure 1. FWD Evaporator Assembly (STD)

Keith Products, Inc.
Maintenance Manual

FIG. ITEM	PART NUMBER	NOMENCLATURE	EFFECT	UNITS PER ASSY
1 1	82-02-102-2	FWD Evaporator Installation		RF
2	82-02-402-1	Panel Assy		1
3	82-02-402-5	Mounting Bracket		1
4	82-02-402-6	Bracket		1
5	82-02-402-7	Cover Plate		1
6	82-00-441-2	Louver		1
7	MS20365-1032	Nut		2
8	NAS221-8	Screw		7
9	ES35002-6	Screw		3
10	JBS2048-2	Evap Assy		1
11	JBS12002-5	Coil Assy		1
12	JBS238-2	Shroud Air Inlet		1
13	JBS239-3	Shroud Assy		1
14	JBS237-1	Blower Housing		1
15	ES61060-2	Motor Assy		1
16	ES73100-1	Blower Wheel		1
17	JBS240-1	Resistor Assy		1

Air Conditioning System -FWD Evaporator (STD)
IPL FIGURE 1

Keith Products, Inc.
Maintenance Manual

FIG. ITEM	PART NUMBER	NOMENCLATURE	EFFECT	UNITS PER ASSY
1 18	ES26104-1	Expansion Valve		1
19	ES49011-2	O-ring		1

Air Conditioning System -FWD Evaporator (STD)
IPL FIGURE 1

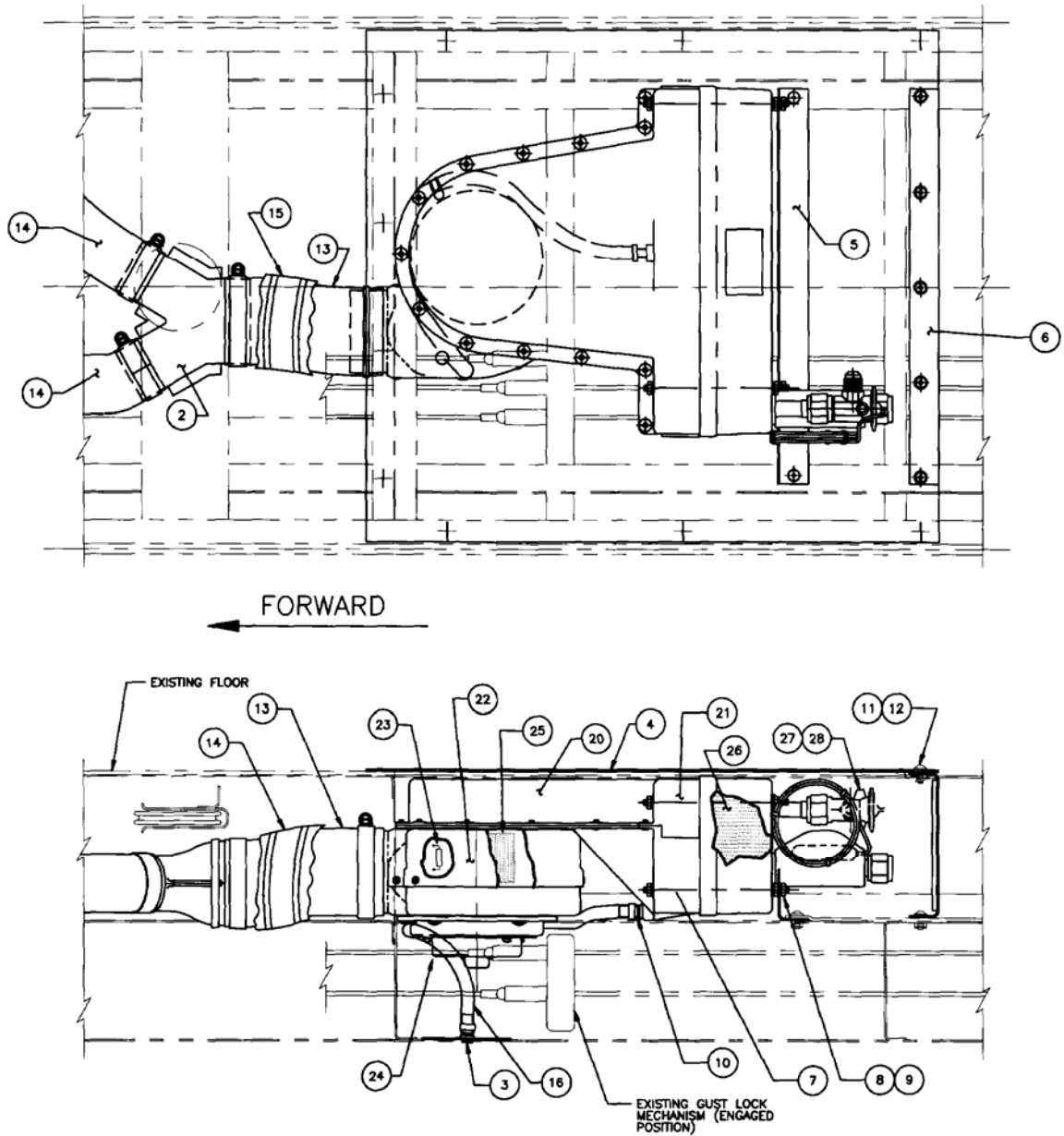

Figure 2. FWD Evaporator Assembly (Cool Stick Option)

Keith Products, Inc.
Maintenance Manual

FIG. ITEM	PART NUMBER	NOMENCLATURE	EFFECT	UNITS PER ASSY
2 1	82-02-119-4	FWD Evaporator Installation (Cool Stick)		RF
2	81-33-411-3	"Y" Assy		1
3	88-00-431-4	Drain Assy		1
4	82-02-402-7	Cover Plate		1
5	82-02-402-8	Mounting Bracket		1
6	82-02-402-1	Panel Assy		1
7	JBS2030-2	Evap Assy		1
20	JBS2034-1	Shroud Assy		1
21	JBS238-2	Shroud Air Inlet		1
22	JBS237-1	Blower Housing		1
23	JBS240-1	Resistor Assy		1
24	ES61060-2	Motor Assy		1
25	ES73100-1	Blower Wheel		1
26	JBS12002-5	Coil Assy		1
27	ES26104-1	Expansion Valve		1

Air Conditioning System -FWD Evaporator (Cool Stick Option)
IPL FIGURE 2

Keith Products, Inc.
Maintenance Manual

FIG. ITEM	PART NUMBER	NOMENCLATURE	EFFECT	UNITS PER ASSY
2 28	ES49011-2	O-ring		1
8	AN960-10L	Washer		2
9	AN315-3	Nut		2
10	ES30043-2	Hose Clamp		2
11	NAS221-10	Screw		6
12	AN960-10	Washer		13
13	ES70009-2	Flex Duct		12 in
14	ES70009-3	Flex Duct		180 in
15	ES06022-1	Insulation Tape		1700 in
16	ES48012-2	Drain Tube		24 in

Air Conditioning System -FWD Evaporator (Cool Stick Option)
IPL FIGURE 2

AFT EVAPORATOR ASSEMBLY

DESCRIPTION AND OPERATION

1. GENERAL

The aft evaporator assembly is located in the aft cabin at the spar cap (at floor level) within the aircraft interior. It consists of an evaporator, expansion valve and blower assembly. The blower supplies conditioned air to the cabin. The evaporator coil cools and dehumidifies the air to be distributed by the blower.

This section of the maintenance manual discusses troubleshooting used for the aft evaporator assembly portion of the air conditioning system. An Illustrated Parts List is included in Figure 1.

TROUBLESHOOTING

1. GENERAL

The following procedure is used for troubleshooting the aft evaporator assembly. For additional troubleshooting procedures involving the electrical aspects of the evaporator blower, see 21-50-01, page 101.

2. TOOLS AND EQUIPMENT

Designation	Ref. No.	Qty	Remarks
Service Pressure Gauge	Comm. Avail.	1	None
28vdc Source		A/R	None

3. EVAPORATOR TROUBLESHOOTING PROCEDURE (Ref. IPL Fig. 1)

- A. Water is Being Blown from Air Outlets.
1. Operate GPU and apply 28 vdc electrical power.
 2. Select air conditioning system to ON.
 3. Check evaporator drain for condensate runoff.
 4. If no runoff, clear drain of blockage or verify that routing is in a down hill orientation.
 5. Select air conditioning OFF, remove electrical power.
- B. No Cooling at Evaporator.
1. Connect service pressure gauge to service ports located near compressor/condenser assembly.
 2. Operate GPU and apply 28 vdc electrical power.
 3. Select air conditioning system to ON.
 4. Check evaporator for proper cooling. If cooling not sufficient, check refrigerant level to ensure that system is correctly charged, this can be confirmed by a clear sight glass (no bubbles) on the top of the receiver dryer. If bubbles are present, add refrigerant till sight glass just clears.
 5. If system is correctly charged, replace expansion valve per Maintenance Practices procedure.

MAINTENANCE PRACTICES

1. GENERAL

The following procedures are used to perform typical maintenance on the aft evaporator assembly.

2. TOOLS AND EQUIPMENT

Designation	Ref. No.	Qty	Remarks
Sealant	ES49000-1	A/R	None
Polyol Ester Oil	Comm. Avail.	A/R	Viscosity Grade 68
Vacuum Cleaner	Comm. Avail.	1	None
Coil Cleaner	Comm. Avail.	A/R	Non-acid based

3. EVAPORATOR MAINTENANCE PROCEDURES (REF. IPL Fig. 1)

A. Expansion Valve Replacement

1. Discharge system in accordance with recovery equipments instructions.
2. Disconnect liquid line from inlet of expansion valve, and cap. Remove the thermal sense bulb from its clamp located on the suction tube of the evaporator and carefully remove insulation covering bulb.
3. Disconnect the fitting that connects the valve to the coil and plug coil fitting.
4. Install new expansion valve and o-ring in the reverse order.
5. Lubricate o-ring with polyol ester oil or apply sealant to fitting mating surfaces prior to assembly.
6. Install the thermal sense bulb such that it makes contact with the suction tube along its entire length. Insulate the bulb thoroughly with insulation.

B. Evaporator Coil Cleaning Procedure

1. Use vacuum cleaner to remove large debris from upstream and downstream coil faces.
2. Spray coil cleaner on both coil faces. Wash off with water.
3. Allow coil to dry thoroughly prior to additional maintenance.

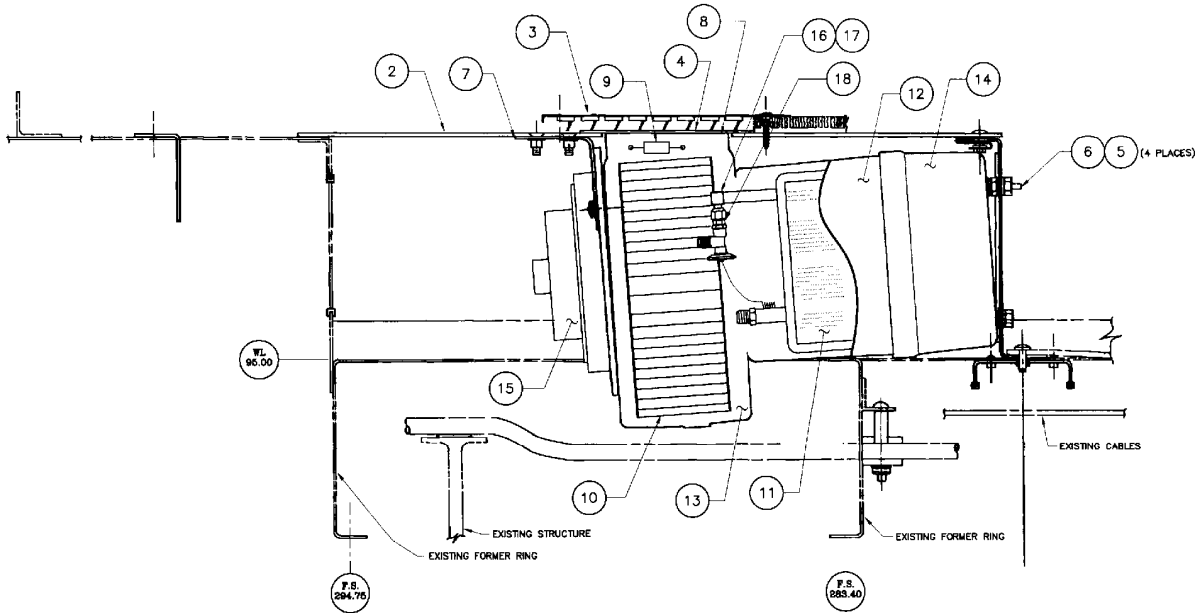

Figure 1. Aft Evaporator Assembly

Keith Products, Inc.
Maintenance Manual

FIG. ITEM	PART NUMBER	NOMENCLATURE	EFFECT	UNITS PER ASSY
1 1	82-02-103-2	AFT Evaporator Installation		RF
2	82-02-403-3	Cover Plate		1
3	82-02-441-2	Louver		1
4	88-00-490-2	Screen		1
5	MS20365-1032	Nut		4
6	AN960-10L	Washer		12
7	82-02-403-7	Bracket		1
8	JBS2048-3	Evap Assy		1
9	JBS240-2	Resistor Assy		1
10	ES73100-2	Blower Wheel		1
11	JBS12002-5	Coil Assy		1
12	JBS239-2	Shroud Assy		1
13	JBS237-1	Blower Housing		1
14	JBS238-1	Shroud Air Inlet		1
15	ES61060-2	Motor Assy		1
16	ES41062-2	90° adapter		1

Air Conditioning System - AFT Evaporator Assembly
IPL FIGURE 1

Keith Products, Inc.
Maintenance Manual

FIG. ITEM	PART NUMBER	NOMENCLATURE	EFFECT	UNITS PER ASSY
1 17	ES49011-2	O-ring		1
18	ES26104-1	Expansion Valve		1

Air Conditioning System - AFT Evaporator Assembly
IPL FIGURE 1