

AIR COMM CORPORATION
Boulder Municipal Airport
3300 Airport Road
Boulder, CO. 80301

Report 206H-221M

**BELL 206A/B CABIN HEATER SYSTEM
INSTALLATION INSTRUCTIONS
(F/W Shut-off Valve/Temp Sensors)**

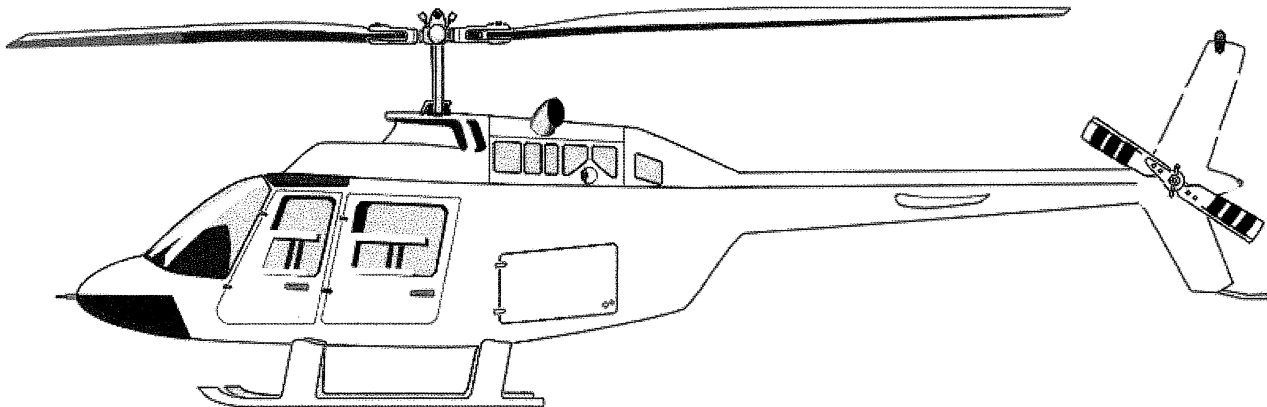

This Document contains:

**Flight Manual Supplement
STC Certificate
Service Instructions**

December 16, 1991

Revisions

| Rev | Description | Date | Appl |
|------------|--|-------------|-------------|
| A | Revision Pg 11 to incorporate revised Circuitry. Added wt data on pg V-1 | 1-31-91 | NS |
| B | Revised document. Deleted outlet flow control aft outlets. Misc minor chgs. | 11-19-92 | NS |
| C | Revised Pg II-2 to add contents of notes 15 & 18 | 4-6-93 | NS |
| D | Revised pgs 9, 10 & 11 to revise wire routing & elect schematic. Added dwgs 206H-505 and 206H-905, to incorporate NTH heater data (206H-201-1). | 06-30-93 | NS |
| E | Revised pg IV-1 to add option wts. Added Pg IV-2. | 11-28-94 | NS |
| F | Revised Pgs I-1 to add 206H-909. Revised Pgs IV-1 & 2 and added Pgs IV-3 & 4 to add 206H-201-1 & 4. Revised Pgs 4 & 5 of SI to add Ejector callouts. | 02-06-95 | NS |
| G | Revised Pgs II-2 & 4 of 13 to add installation And testing information for temp sensors & Firewall shutoff valve. | 10-24-05 | |

Table of Contents

| <u>Item</u> | <u>Page</u> |
|---|--------------------|
| Revisions | i |
| Table of contents | ii |
| Introduction | I-1 |
| References | I-1 |
| Installation Instructions – Basic Heater System | II-1 |
| Installation Instructions – Defroster System | III-1 |
| Weight and Balance Data | IV-1 |
| Flight Manual Supplement | V-1 |
| STC Certificate | VI-1 |
| Service Instructions | VII-1 |

Introduction

This document presents a step – by – step procedure for the installation of the ACC 206H-201 Cabin heater system in the Bell 206 A/B Series Helicopter. The instructions contained herein are intended to supplement the information contained on the installation drawings.

This manual provides additional information which is required for operation and maintenance of the aircraft. This data is contained in sections V, VI, and VII. After completion of the installation, the applicable sections are to be removed from this document, and placed with the appropriate existing aircraft historical documents.

References

1. ACC Drawing 206H-201; Heater Installation
2. ACC Drawing 206H-503; Bleed Air Plumbing Installation
3. ACC Drawing 206H-505; Bleed Air Plumbing (NTH)
4. ACC Drawing 206H-526; Bleed Air Plumbing (optional “High Output” system)
5. ACC Drawing 206H-904; Heater Ejector Installation
6. ACC Drawing 206H-800; Installation – Temperature Sensors
7. ACC Drawing 206H-905; Heater Ejector Installation (NTH)
8. ACC Drawing 206H-909; Heater Ejector Installation (206 A/B)
9. ACC Drawing 206H-986; Windshield Defroster Installation (optional)
10. AC43.13.1A; Acceptable Practices, Aircraft Alteration and Repair Manual.

This Area Intentionally Left Blank

Installation Instructions – Basic Heater System

1. Review the system installation drawings and read completely through the installation instructions. **Be sure to read notes on ALL drawings.**
2. Open up the aircraft.
 - a. Remove the upper fairing.
 - b. Open engine cowling.
 - c. Remove both forward seat panels and the panel under the collective stick.
 - d. Remove the forward console side panels if a defroster is to be installed.
3. Mount the main heater valve assembly in the pilots seat box panel as shown pgs 2 and 3 of drawing 206H-201.
4. Drill tubing penetration holes, as shown on plumbing installation drawings.
 - a. L/H forward corner of engine firewall.
 - b. Center of console bulkheads.
5. Drill ejector adapter mounting holes in aft panel of front seat box as shown by the Ejector Installation Drawing.
6. Mount heater ejectors as shown in the Ejector Installation Drawing.
7. Install firewall shut-off valve as shown on the Plumbing Installation Drawing.
8. Install restrictors and engine compartment tubes and hose I/A/W the Plumbing Installation Drawing.
9. Install (optional) Defroster as shown in the Defroster Installation Drawing.
10. Install the tubes on the cabin top as shown on the plumbing drawing. From tube A/R to achieve proper fit and clamp per applicable drawing requirements and AC43.13.1A.
11. Install the tube in the broom closet as shown by the plumbing installation drawing. Insert tube from inside the cabin.
12. Connect valve and heater ejectors. Form tubing as required to achieve proper fit. Slide ejectors for or aft as required to connect tubing.
13. Review and check off all drawing notes and drawing requirements.

Continued

Installation Instructions – Basic Heater System (continued)

14. Inspect all plumbing fittings and hardware for security.
15. After system installation insure that clearance exists between plumbing tubes and flight controls. Cycle flight controls through there full range of travel to insure clearance.
16. Leak test system in accordance with instructions on plumbing installation drawing. Also verify operation of warning light and firewall shut-off valve. **Note: Air pressure (Shop air (60 psig, min.) or engine bleed air) must exist for the firewall shutoff valve to operate properly.**
17. Install “temp sensors,” switch, warning light, and wiring as shown in the electrical installation drawing.
18. Verify operation of the warning light and firewall shut-off valve.
 - a. Air pressure (Shop or Bleed Air) must exist for firewall shutoff valve to operate.
 - b. Turn heater switch from off to on. (heater over temp should be off)
 - c. Using a heat gun carefully apply heat to one of the temperature sensors (do not exceed 200° F). Heater over temp light should come on, and firewall shut off valve should close. Remove heat source and allow area to cool.
 - d. After the temperature sensor has cooled, cycle heater switch from ON to OFF, and back to ON. The over temp light should again be off, and the heater firewall shutoff valve should again be open.
19. Test run using aircraft engine bleed air, and check for heater operation.

This area intentionally left blank

Installation Instructions – Defroster System

1. Review Drawing 206H-986 (read all notes)
2. Install the Defroster Valve and Hose assembly.
3. Locate and drill necessary holes per the defroster installation drawing in the center console panel between the pilot's seats.
4. Install defroster ejectors in existing aircraft defroster diffusers.
5. Connect defroster bleed air plumbing.
6. Check all fittings and fasteners for security.

This area intentionally left blank

Cabin Heater Weight and Balance Data – NTH Heater

| | Wt. (lbs) | X (in) | Wx (in-lbs) |
|--|----------------------|-------------------|------------------------|
| 1. Standard Cabin Heater System (includes windshield defroster) 206H-201-1 | 14.27 | 92.0 | 1331 |
| Add on options: | | | |
| 2. Chin Bubble Defroster | .50 | 19.5 | 10 |
| 3. Forward Outlet Side Window Defog (206H-924-1) | .49 | 56.0 | 27 |
| 4. Forward and Aft Side Window Defog (206H-924-2) | .98 | 67.60 | 66 |

This area is intentionally left blank

Cabin Heater Weight and Balance Data – Standard Heater

| | Wt (lbs) | X (in) | Wx (in-lb) |
|--|---------------------|-------------------|-----------------------|
| 1. Standard Cabin Heater System (includes windshield defroster) 206H-201-2 | 14.77 | 92.0 | 1359 |
| Add on options: | | | |
| 2. Chin Bubble Defroster 206H-988-1 | .50 | 19.5 | 10 |
| 3. Forward Outlet Side Window Defog (206H-924-1) | .49 | 56.0 | 27 |
| 4. Forward and Aft Side Window Defog (206H-924-2) | .98 | 67.60 | 66 |

This area is intentionally left blank

Cabin Heater Weight and Balance Data – Arctic Heater (Hi-Output)

| | Wt (lbs) | X (in) | Wx (in-lb) |
|--|---------------------|-------------------|-----------------------|
| 1. Arctic Cabin Heater System (includes windshield defroster) 206H-201-3 | 17.30 | 86.8 | 1501 |
| Add on options: | | | |
| 2. Chin Bubble Defroster 206H-988-1 | .50 | 19.5 | 10 |
| 3. Forward Outlet Side Window Defog (206H-924-1) | .49 | 56.0 | 27 |
| 4. Forward and Aft Side Window Defog (206H-924-2) | .98 | 67.60 | 66 |

This area is intentionally left blank

Cabin Heater Weight and Balance Data – Crashworthy Seat

| | Wt (lbs) | X (in) | Wx (in-lb) |
|--|---------------------|-------------------|-----------------------|
| 1. Standard Cabin Heater System (includes windshield defroster) 206H-201-4 | 14.77 | 92.0 | 1359 |
| Add on options: | | | |
| 2. Chin Bubble Defroster 206H-988-1 | .50 | 19.5 | 10 |
| 3. Forward Outlet Side Window Defog (206H-924-1) | .49 | 56.0 | 27 |
| 4. Forward and Aft Side Window Defog (206H-924-2) | .98 | 67.60 | 66 |

This area is intentionally left blank

FLIGHT MANUAL SUPPLEMENT

206 Commercial – 206H-201

206B NTH – 206H-200

AIR COMM CORPORATION
3300 AIRPORT ROAD
BOULDER, COLORADO 80301

FAA APPROVED

BELL HELICOPTERS
MODEL 206B
C20B, C20J, and C-20R/2 ENGINES

FLIGHT MANUAL SUPPLEMENT
FOR
CABIN HEATING SYSTEM

206H-201

REG: _____
S/N: _____

The information contained in this document is FAA approved material, which must be carried in the basic Flight Manual, after the rotorcraft has been modified by installation of the windshield defroster system in accordance with Air Comm Corporation STC No. SH3887NM.

The information in this document supplements or supercedes the basic manual only in the items contained herein. For Limitations, Procedures, and Performance Data not contained in this supplement, consult the basic Flight Manual.

Log of Pages

FAA APPROVED
SUPPLEMENT

MODEL 206B
FLIGHT MANUAL

CABIN HEATING SYSTEM

| Log of Pages | | | |
|----------------|----------|-------|----------|
| Original Pages | Rev. No. | Pages | Rev. No. |
| 1-27 | 0 | | |
| 1-28 | 2 | | |

FAA APPROVAL DATE: Jan 3, 1992

APPROVED: *Richard Jennings*
Richard Jennings, Supervisor
Denver Aircraft Certification
Field Office
Denver, Colorado

MODEL 206B
FLIGHT MANUAL

CABIN HEATING SYSTEM

| No. | Log of Revisions | | FAA Appl |
|--|------------------|-------------------|-------------------------|
| | Rev. Date | Pgs Revised | |
| 0 | JAN 3 1992 | Original Issue | |
| 1 | JAN 4 1993 | 4, 8 & 10 | <i>R.E. [Signature]</i> |
| 2 | AUG 10 1993 | 1, 5, 6, 7, 8 & 9 | <i>R.E. [Signature]</i> |
| <p>Note: Revisions are indicated by a black vertical line.</p> | | | |

INTRODUCTION

The cabin heating system is a bleed air type which consists of bleed air plumbing, a firewall shut-off valve, a heater control valve, and four heater ejectors, as shown in figure 1.

The bleed air flows from the engine compressor through the bleed lines to the ejectors, where it is mixed with cabin air and exhausted to both the front and rear passengers. The ejectors are located under the front seats. The warm air is ducted forward and aft through swivel outlets which are located in the seat box structure. The outlet flow can be individually adjusted by rotation of the swivel outlet (two fwd outlets).

The firewall-mounted shut-off valve is electrically activated. The ON-OFF switch is mounted in the overhead console. The valve will automatically close if there is a loss of electrical power to the valve.

Temperature sensors are installed as a part of the heater system. In the case of an over-temperature condition, the sensors will close, resulting in illumination of an amber "heater over-temp" light, and automatic closure of the firewall shut-off valve. The heater ON/OFF switch must be set to OFF in order to reset the firewall shut-off valve and the heater over-temp light. The heater control is located on the front of the seat box.

CABIN HEATING SYSTEM

INTRODUCTION (cont'd)

The system features a windshield defroster system. This system consists of an ON-OFF valve located in the center console and ejectors located in each defroster diffuser. The ejectors pump warm air across the windshield. The original defroster blowers are not required but may remain installed at the option of the operator. The defroster and heater may be used simultaneously. The system components and general arrangement is shown by Figure 1.

A drain valve is also incorporated as a part of the heater system. This valve is used to drain cleaning solution overboard when washing the internal parts of the engine.

The valve, which is located inside the LH engine access door, is automatic (closed by engine pressure).

An alternate heater ejector configuration, which is shown by figure 2, consists of two forward and one RH rear ejector. All ejectors are configured with the outlet flow control feature.

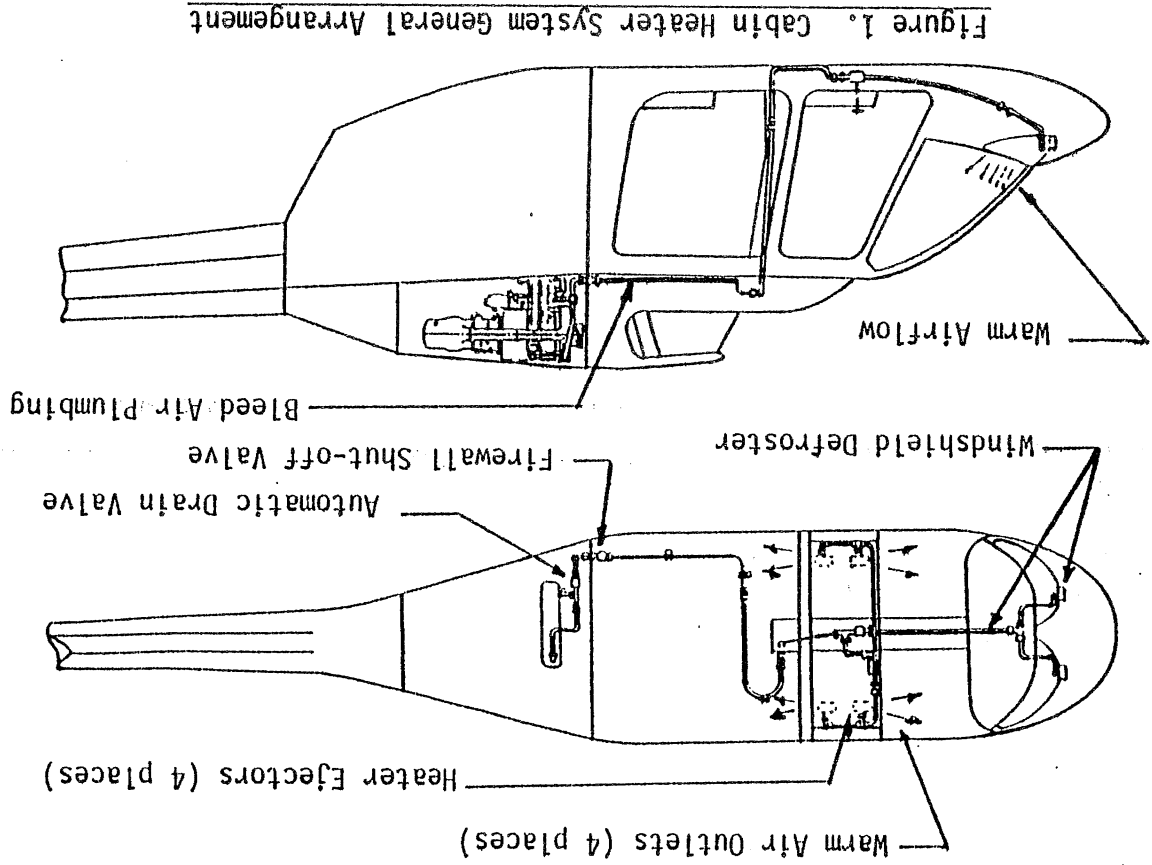

Figure 1. Cabin Heater System General Arrangement

MODEL 206B
FLIGHT MANUAL

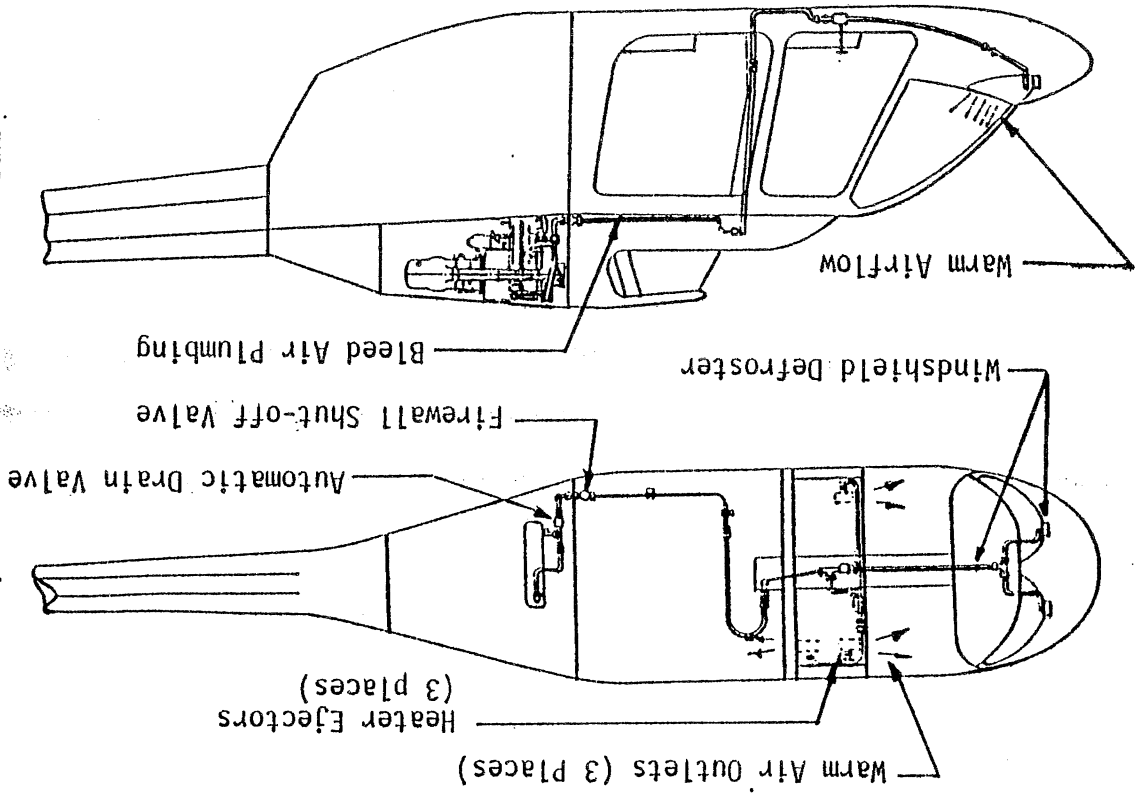

Figure 2. Cabin Heater System General Arrangement
(NTH Configuration)

MODEL 206B
FLIGHT MANUAL

CABIN HEATING SYSTEM

SECTION 1 OPERATING LIMITATIONS

PLACARDS AND MARKINGS

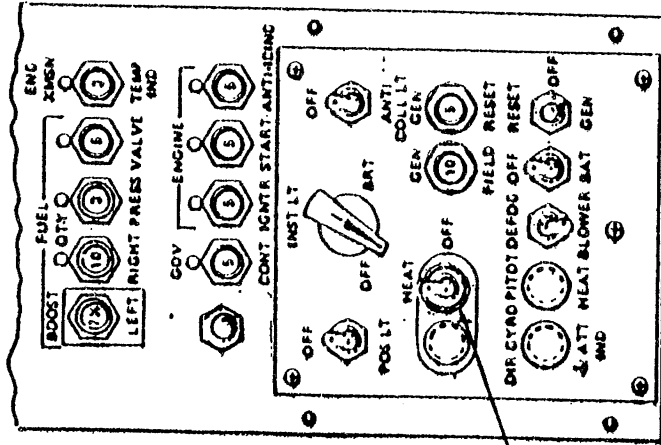

Heater ON-OFF
Switch

Heater ON-OFF Switch location in overhead console.

MODEL 206B
FLIGHT MANUAL

CABIN HEATING SYSTEM

SECTION 1 (cont'd) OPERATING LIMITATIONS

PLACARDS AND MARKINGS (cont'd)

Heater Overtemp Warning

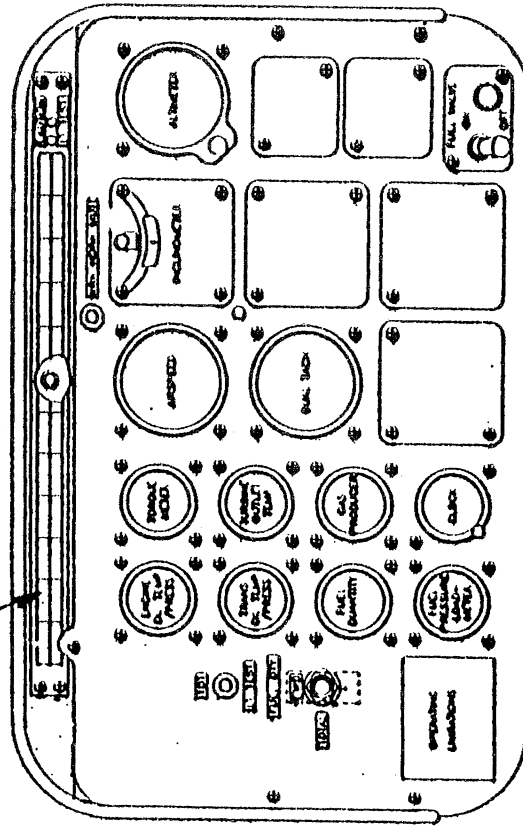

Heater "over-temp" light location on instrument panel.

CABIN HEATING SYSTEM

SECTION 1 (cont'd) OPERATING LIMITATIONS

PLACARDS AND MARKINGS (cont'd)

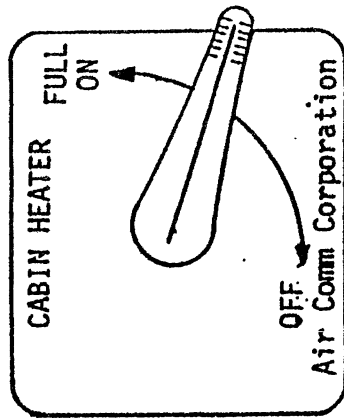

Located on front side of RH seat support box.

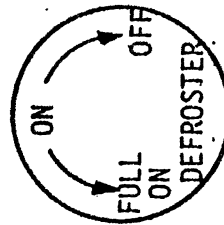

Located on the Defroster Control Knob, which is located in the center console.

CABIN HEATING SYSTEM

SECTION 1 (cont'd) OPERATING LIMITATIONS

PLACARDS AND MARKINGS (cont'd)

Note: For maximum heater performance align index on air outlet with FULL ON position as shown.

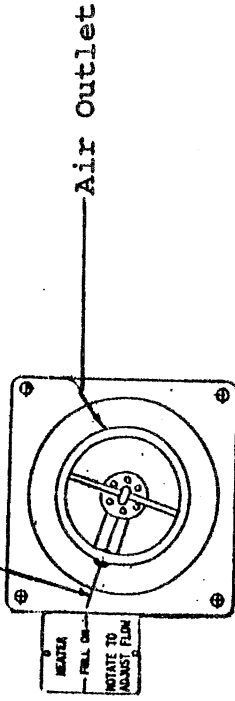

Locate adjacent to Air Outlets as shown (two forward outlets only).

CABIN HEATING SYSTEM

SECTION 2

NORMAL PROCEDURES

ENGINE PRESTART CHECK

Heater ON-OFF switch - OFF
Heater Control - OFF

BEFORE TAKEOFF

Heater and Defroster Control - as desired.

Note

For maximum heater performance all
air outlets must be rotated to the
full on position.

IN FLIGHT OPERATIONS

Note: TOT increases with bleed air heater
operations. Observe turbine outlet tempera-
ture limitation. Heater Control - as desired.

DESCENT AND LANDING

Heater and Defroster Control - as desired.

SECTION 3

EMERGENCY PROCEDURES

Operate cabin heater ON-OFF Switch to OFF
for any of the following emergencies:

- Heater "over-temp" light illuminated
- Engine Failure
- Engine Over-temperature
- Fuel Control and/or Governor Failure
- Insufficient Power

CABIN HEATING SYSTEM

SECTION 3 (cont'd)

EMERGENCY PROCEDURES

Note

Illumination of the heater "over-
temp" warning light may be an indi-
cation of an overheat condition.
The heater ON-OFF switch should be
placed in the OFF position. Do not
attempt to use the heater until
the cause of the "over-temp"
indication has been determined.

SECTION 4

MALFUNCTION PROCEDURES

No change.

SECTION 5

PERFORMANCE DATA

Applicable to aircraft with C-20J or
C-20R/2 engines:

Reduce the performance data in basic flight
manual or optional equipment supplement in
accordance with the following data and/or
charts when the bleed air heater or
defroster is operating. Performance decre-
ments are shown for the standard engine
air inlet and for the particle separator
induction system.

MODEL 206B
FLIGHT MANUAL

CABIN HEATING SYSTEM

SECTION 5 (cont'd) PERFORMANCE DATA

Complete hover performance is presented herein for the snow deflector, which includes losses due to the particle separator. EXAMPLE: What gross weight loss in hover performance could be expected under the following conditions:

| | |
|---------------------------------|--------------------|
| Standard engine inlet | Standard skid gear |
| IGE Hover | Takeoff power |
| Outside air temp = -15° | Anti-ice off |
| Pressure altitude = 14,000 feet | |

Using the appropriate IGE chart, enter OAT (-15°C), move vertically to intersect pressure altitude curve (or outermost curve, whichever comes first), then proceed horizontally to obtain the gross weight loss to the weight obtained from appropriate hover performance chart in basic flight manual supplement.

There is no loss in hover performance when the outside air temperature is to the left of the pressure altitude curve. It can be seen on the chart covering the above conditions that at -15°C there is no loss in IGE hover performance from sea level to 12,000 feet.

Applicable to aircraft with C-20B, C-20J and C-20R/2 engines:

**HOVER CEILING DECREASE
DUE TO BLEED AIR HEATER OPERATION
STANDARD INLET WITH STANDARD SKID GEAR**

IN GROUND EFFECT **TAKEOFF POWER**
-40° TO 30°C

GENERATOR 22.3 AMPS ANTI-ICE OFF
SKID HEIGHT 2.0 FT. (0.6 METER) ENGINE RPM 100%
WITH ANTI-ICE ON APPLY ADDITIONAL DECREMENT FROM
BASIC MANUAL OR APPROPRIATE SUPPLEMENT

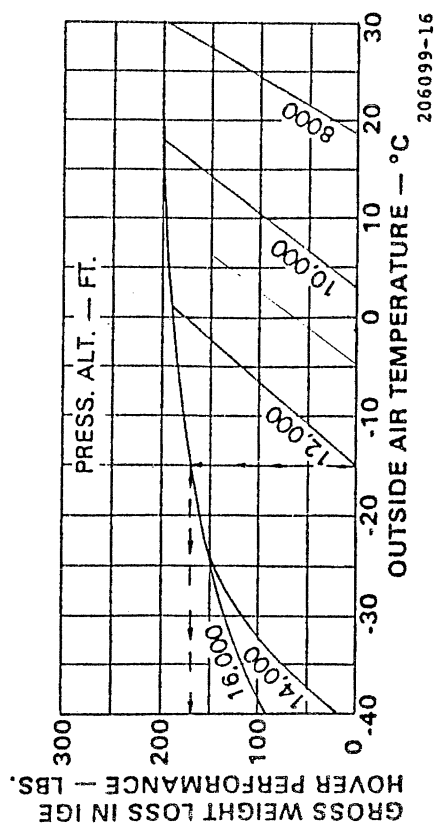

Applicable to aircraft with C-20B, C-207J and C-20R/2 engines:

**HOVER CEILING DECREASE
DUE TO BLEED AIR HEATER OPERATION
STANDARD INLET WITH HIGH SKID OR ANY FLOAT GEAR**

IN GROUND EFFECT **TAKEOFF POWER**
-40° TO 30°C

GENERATOR 22.3 AMPS ANTI-ICE OFF
SKID HEIGHT 3.0 FT. (0.9 METER) ENGINE RPM 100%
WITH ANTI-ICE ON APPLY ADDITIONAL DECREMENT FROM
APPROPRIATE SUPPLEMENT

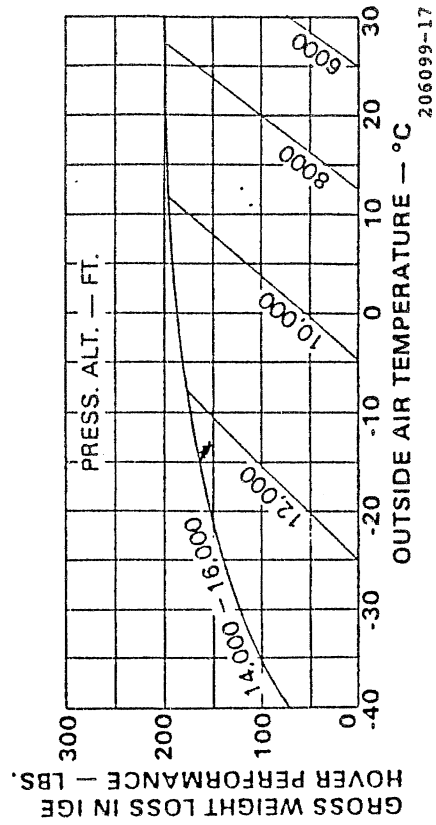

Applicable to aircraft with C-20B, C-20J and C-20R/2 engines:

**HOVER CEILING DECREASE
DUE TO BLEED AIR HEATER OPERATION**
STANDARD INLET WITH ANY SKID OR FLOAT GEAR

OUT OF GROUND EFFECT TAKEOFF POWER
-40° TO 30°C

GENERATOR 22.3 AMPS
SKID HEIGHT 40 FT. (12.2 METERS)
WITH ANTI-ICE ON APPLY ADDITIONAL DECREMENT FROM BASIC MANUAL OR APPROPRIATE SUPPLEMENT

ANTI-ICE OFF
ENGINE RPM 100%

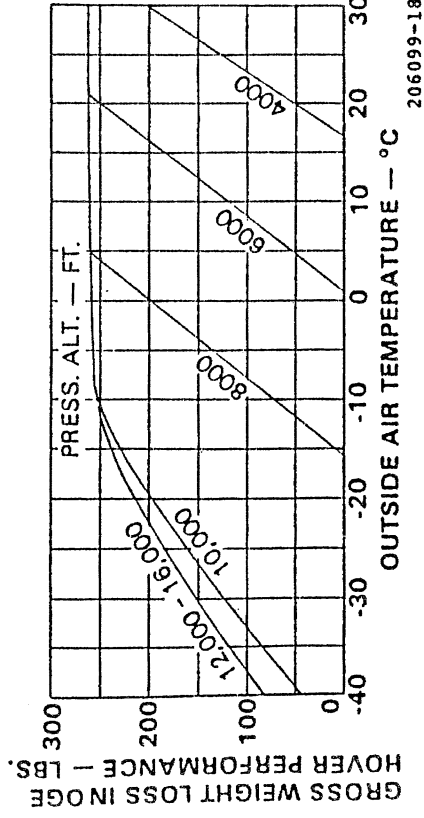

Applicable to aircraft with C-20B, C-20J and C-20R/2 engines:

**HOVER CEILING DECREASE
DUE TO BLEED AIR HEATER OPERATION**
PARTICLE SEPARATOR WITH STANDARD SKID GEAR

IN GROUND EFFECT TAKEOFF POWER
-40° TO 30°C

GENERATOR 22.3 AMPS
SKID HEIGHT 2.0 FT. (0.6 METER)
WITH ANTI-ICE ON APPLY ADDITIONAL DECREMENT FROM PARTICLE SEPARATOR SUPPLEMENT

ANTI-ICE OFF
ENGINE RPM 100%

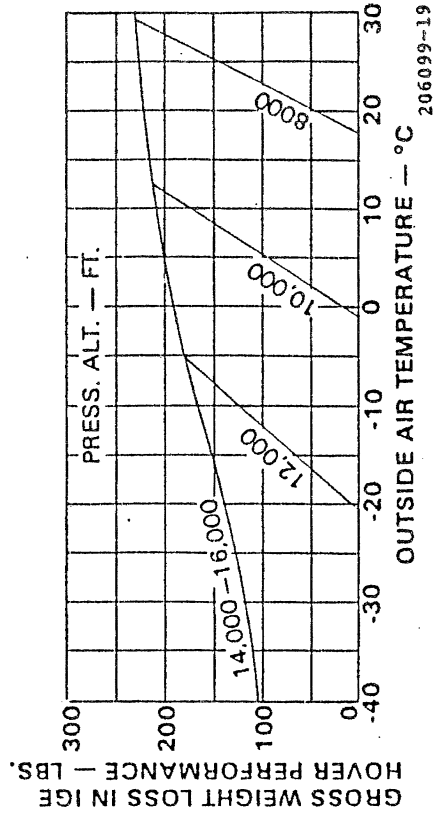

Applicable to aircraft with C-20B, C-20J and C-20R/2 engines:

**HOVER CEILING DECREASE
DUE TO BLEED AIR HEATER OPERATION
PARTICLE SEP. WITH HIGH SKID OR ANY FLOAT GEAR
IN GROUND EFFECT TAKEOFF POWER**

-40° TO 30°C
GENERATOR 22.3 AMPS ANTI-ICE OFF
SKID HEIGHT 3.0 FT.(0.9 METER) ENGINE RPM 100%
WITH ANTI-ICE ON APPLY ADDITIONAL DECREMENT FROM
PARTICLE SEPARATOR SUPPLEMENT

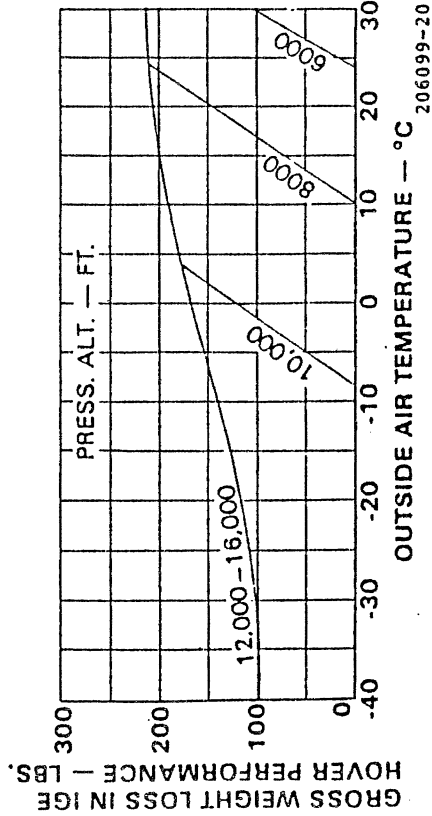

Applicable to aircraft with C-20B, C-20J and C-20R/2 engines:

**HOVER CEILING DECREASE
DUE TO BLEED AIR HEATER OPERATION
PARTICLE SEPARATOR WITH ANY SKID OR FLOAT GEAR
OUT OF GROUND EFFECT TAKEOFF POWER**

-40° TO 30°C
GENERATOR 22.3 AMPS ANTI-ICE OFF
SKID HEIGHT 40 FT. (12.2 METERS) ENGINE RPM 100%
WITH ANTI-ICE ON APPLY ADDITIONAL DECREMENT FROM
PARTICLE SEPARATOR SUPPLEMENT

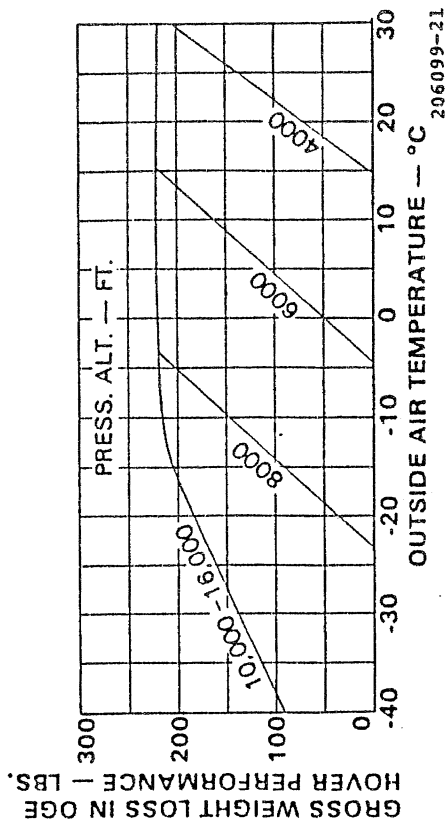

FAA APPROVED
 MODEL 206B SUPPLEMENT
 FLIGHT MANUAL
 CABIN HEATING SYSTEM PERFORMANCE DATA
 SECTION 5

Applicable to aircraft with C-20B, C-20J and C-20R/2 engines:

HOVER CEILING
 SNOW DEFLECTOR WITH STANDARD SKID GEAR
 IN GROUND EFFECT TAKEOFF POWER
 0° TO 30°C
 GENERATOR 22.3 AMPS ANTI-ICE OFF
 SKID HEIGHT 2.0 FT. (0.6 METER) ENGINE RPM 100%
 WITH ANTI-ICE ON GROSS WEIGHT IS 245 LBS (111.1 Kg) LESS

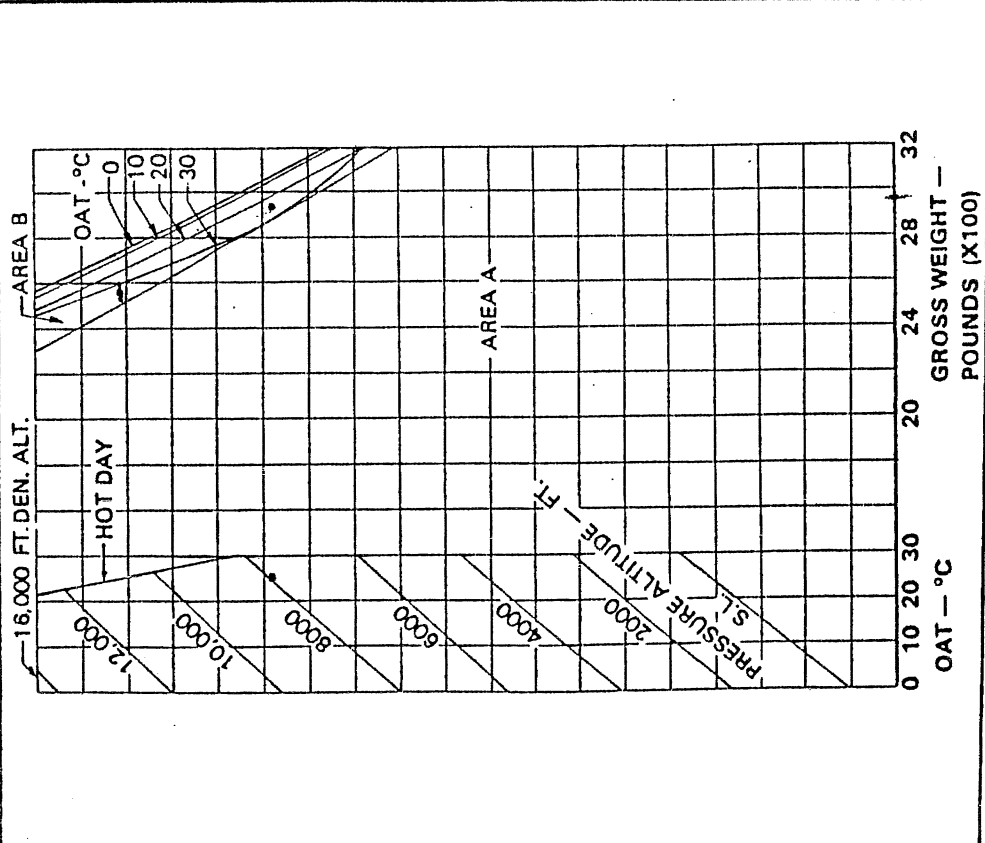

FAA APPROVED
 MODEL 206B SUPPLEMENT
 FLIGHT MANUAL
 CABIN HEATING SYSTEM PERFORMANCE DATA
 SECTION 5

Applicable to aircraft with C-20B, C-20J & C-20R/2 engines

HOVER CEILING
 SNOW DEFLECTOR WITH STANDARD SKID GEAR
 IN GROUND EFFECT TAKEOFF POWER
 0° TO -40°C
 GENERATOR 22.3 AMPS ANTI-ICE OFF
 SKID HEIGHT 2.0 FT. (0.6 METER) ENGINE RPM 100%
 WITH ANTI-ICE ON GROSS WEIGHT IS 245 LBS (111.1 Kg) LESS

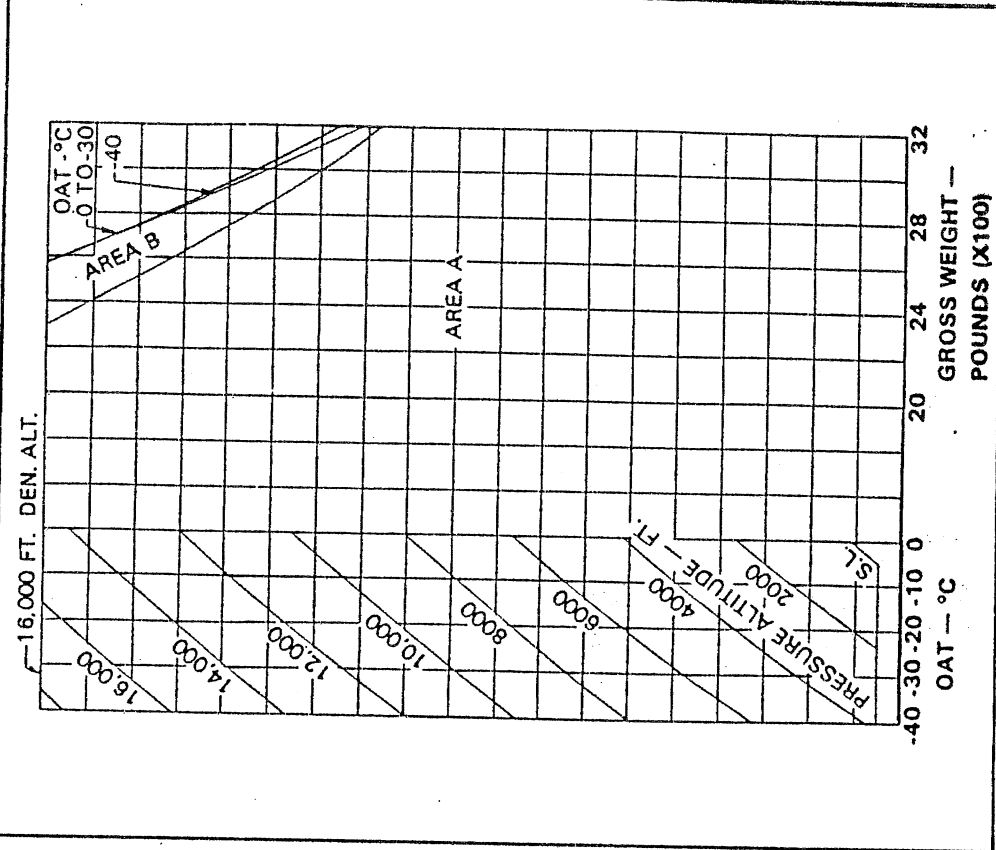

CABIN HEATING SYSTEM PERFORMANCE DATA
 SECTION 5

Applicable to aircraft with C-20B, C-20J and C-20R/2 engines:

HOVER CEILING
 SNOW DEFLECTOR WITH HIGH SKID OR ANY FLOATGEAR
 IN GROUND EFFECT TAKEOFF POWER

0° TO 30°C

GENERATOR 22.3 AMPS ANTI-ICE OFF
 SKID HEIGHT 3.0 FT.(0.9 METER) ENGINE RPM 100%
 WITH ANTI-ICE ON GROSS WEIGHT IS 225 LBS (102.1 Kg) LESS

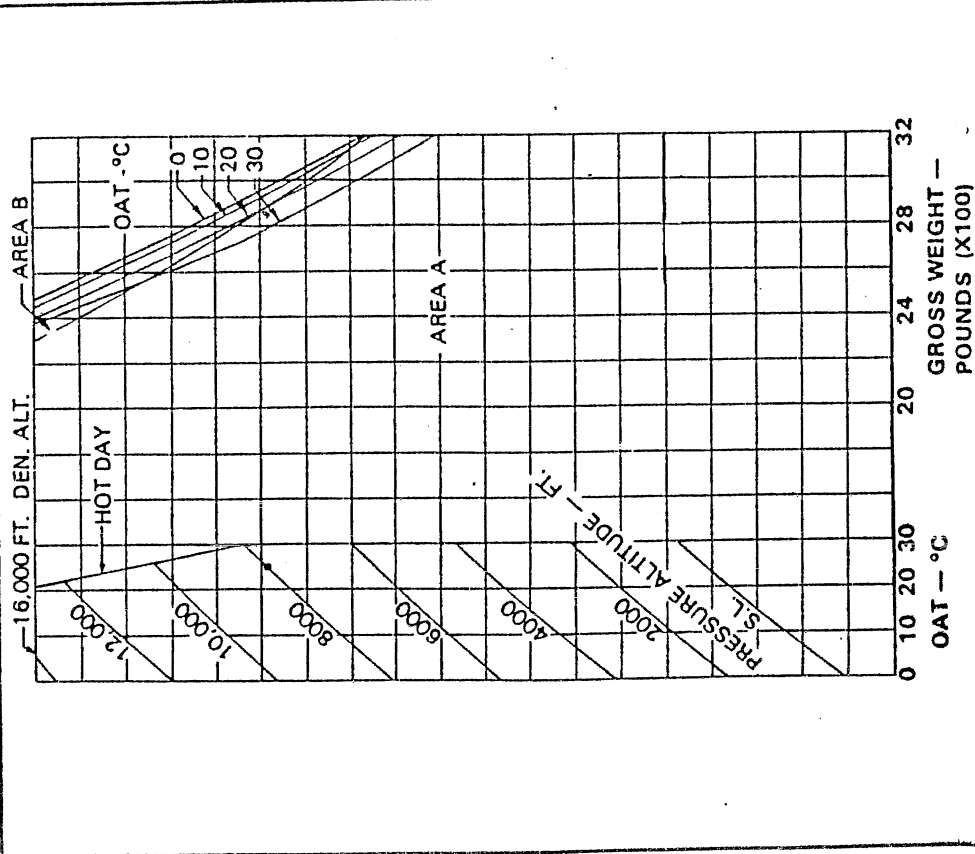

CABIN HEATING SYSTEM PERFORMANCE DATA
 SECTION 5

Applicable to aircraft with C-20B, C-20J and C-20R/2 engines:

HOVER CEILING

SNOW DEFLECTOR WITH HIGH SKID OR ANY FLOATGEAR
 IN GROUND EFFECT TAKEOFF POWER

0° TO -40°C

GENERATOR 22.3 AMPS ANTI-ICE OFF
 SKID HEIGHT 3.0 FT.(0.9 METER) ENGINE RPM 100%
 WITH ANTI-ICE ON GROSS WEIGHT IS 225 LBS (102.1 Kg) LESS

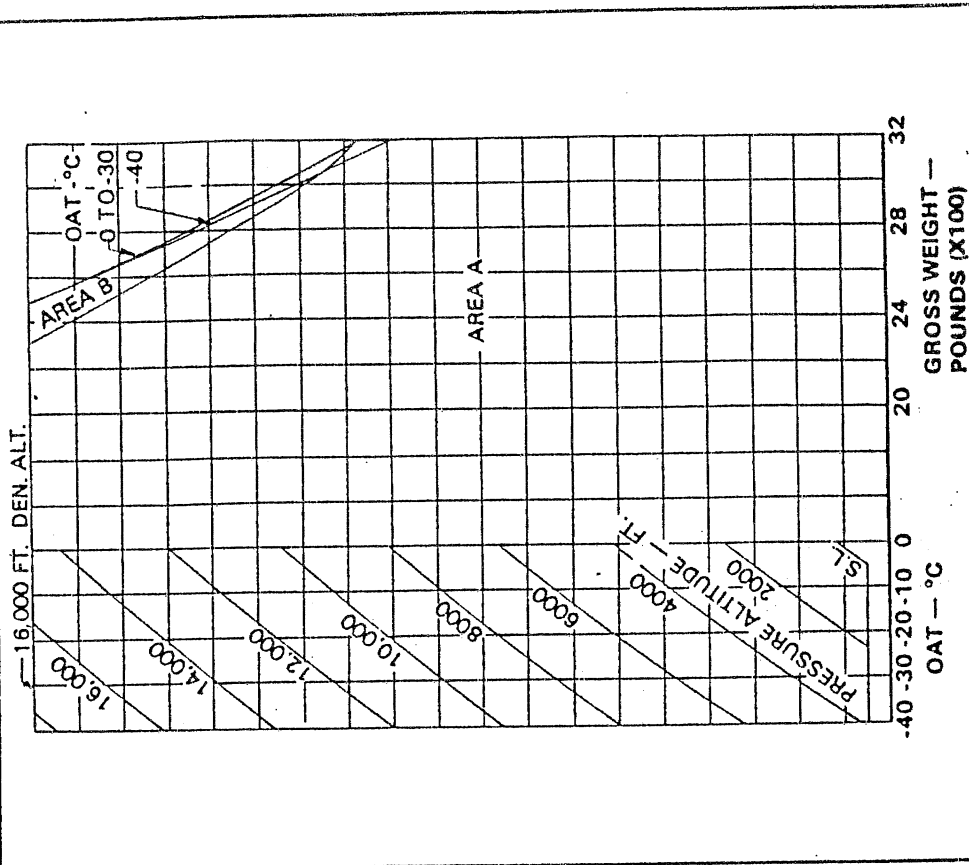

Applicable to aircraft with C-20B, C-20J & C-20R/2 engines:

HOVER CEILING
 SNOW DEFLECTOR WITH ANY SKID OR FLOAT GEAR
 OUT OF GROUND EFFECT TAKEOFF POWER
 0° TO 30°C
 GENERATOR 22.3 AMPS ANTI-ICE OFF
 SKID HEIGHT 40 FT. (12.2 METERS) ENGINE RPM 100%
 WITH ANTI-ICE ON GROSS WEIGHT IS 260 LBS (117.9 Kg) LESS

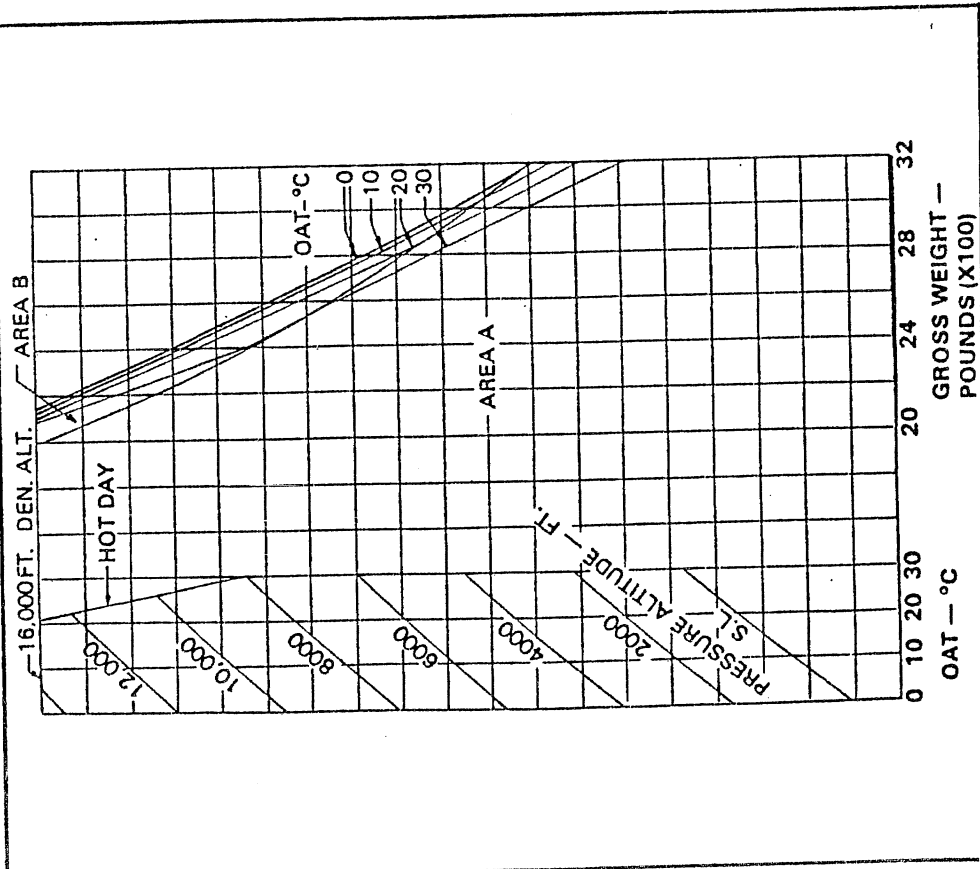

Applicable to aircraft with C-20B, C-20J & C-20R/2 engines

HOVER CEILING
 SNOW DEFLECTOR WITH ANY SKID OR FLOAT GEAR
 OUT OF GROUND EFFECT TAKEOFF POWER
 0° TO -40°C
 GENERATOR 22.3 AMPS ANTI-ICE OFF
 SKID HEIGHT 40 FT. (12.2 METERS) ENGINE RPM 100%
 WITH ANTI-ICE ON GROSS WEIGHT IS 260 LBS (117.9 Kg) LESS

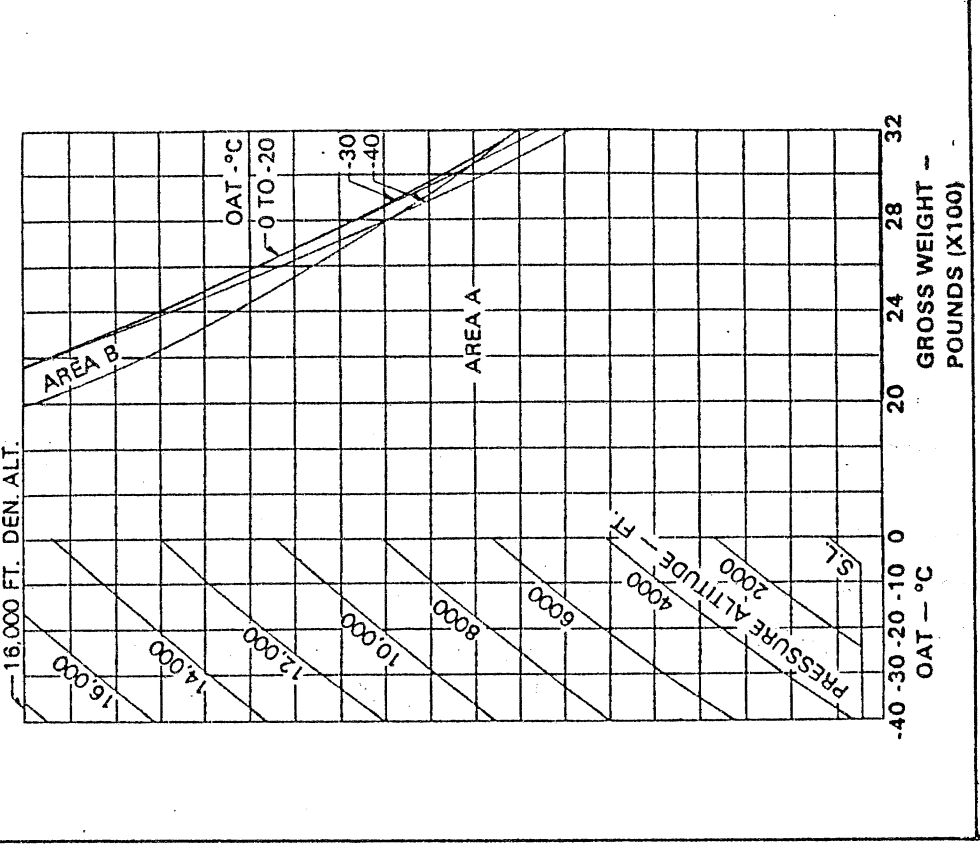

Applicable to aircraft with C-20B, C-20J and C-20R/2
engines:

**RATE OF CLIMB DECREASE
DUE TO BLEED AIR HEATER OPERATION
ANY INLET WITH ANY SKID OR FLOAT GEAR**

TAKEOFF POWER

GENERATOR 22.3 AMPS ANTI-ICE OFF
V IND 60 MPH (52 KNOTS) ENGINE RPM 100%
WITH ANTI-ICE ON APPLY ADDITIONAL DECREMENT FROM
BASIC MANUAL OR APPROPRIATE SUPPLEMENT.

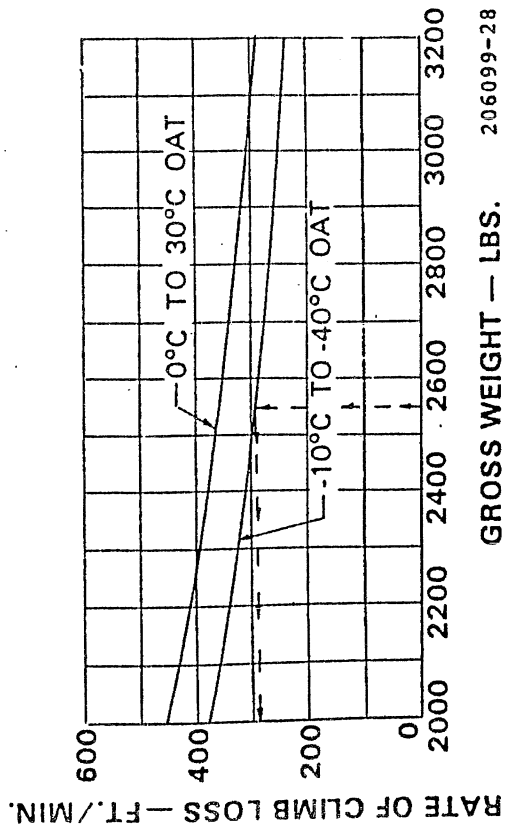

GROSS WEIGHT — LBS. 206099-28

Applicable to aircraft with C-20B, C-20J and C-20R/2
engines:

**RATE OF CLIMB DECREASE
DUE TO BLEED AIR HEATER OPERATION
ANY INLET WITH ANY SKID OR FLOAT GEAR**

MAXIMUM CONTINUOUS POWER

GENERATOR 22.3 AMPS ANTI-ICE OFF
V IND 60 MPH (52 KNOTS) ENGINE RPM 100%
WITH ANTI-ICE ON APPLY ADDITIONAL DECREMENT FROM
BASIC MANUAL OR APPROPRIATE SUPPLEMENT.

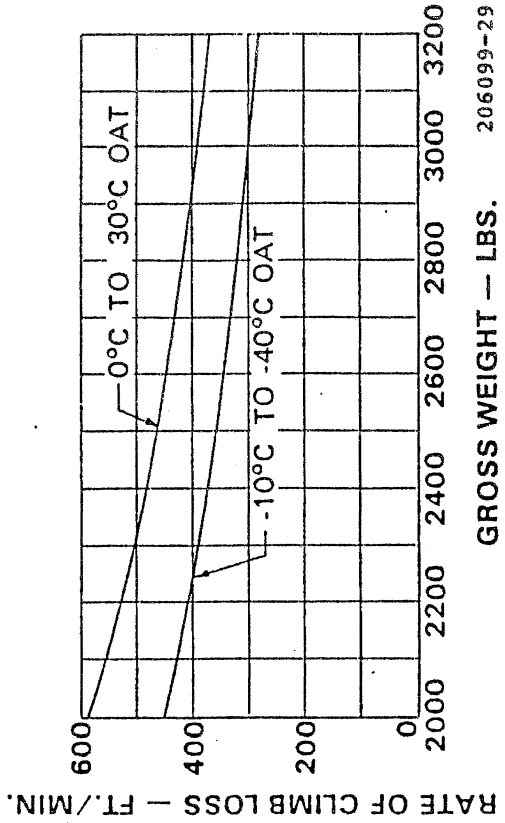

GROSS WEIGHT — LBS. 206099-29

STC CERTIFICATE

United States of America
Department of Transportation — Federal Aviation Administration
Supplemental Type Certificate

Number SH3887NM

This certificate, issued to Air Comm Corporation

certifies that the change in the type design for the following product with the limitations and conditions therefor as specified hereon meets the airworthiness requirements of Part 6 of the Civil Air Regulations.

Original Product — Type Certificate Number: H2SW

Make: Bell Helicopter Textron

Model: 206A, 206B, 206L, 206L-1, 206L-3, 206L-4

Description of Type Design Change:

Installation of bleed air cabin heating system and/or windshield defroster system in accordance with Air Comm Corp. Drawing List DL-206H, Revision N, dated February 9, 1994, or later FAA approved revision.

Limitations and Conditions:

1. FAA approved Flight Manual Supplement for the 206H-200 bleed air cabin heater in Bell Helicopter Models 206A and 206B dated December 24, 1987, or later FAA approved revision is required.
2. FAA approved Flight Manual Supplement for the 206H-202 bleed air cabin heater in Bell Helicopter Models 206L, 206L-1, 206L-3, and 206L-4 dated December 24, 1987, or later FAA approved revision is required.

(See continuation sheet, page 3 of 3)

This certificate and the supporting data which is the basis for approval shall remain in effect until surrendered, suspended, revoked, or a termination date is otherwise established by the Administrator of the Federal Aviation Administration.

Date of application: October 12, 1987

Date issued:

Date of issuance: December 24, 1987

Date amended: 7/19/89, 11/2/90, 12/3/92
1/4/93; February 15, 1994

By direction of the Administrator



Richard E. Jennings
RICHARD E. JENNINGS (Signature) Manager
Denver Aircraft Certification Field Office
Northwest Mountain Region, Denver, Colorado
(Title)

Any alteration of this certificate is punishable by a fine of not exceeding \$1,000, or imprisonment not exceeding 3 years, or both.

This certificate may be transferred in accordance with FAR 21.47.

United States of America
Department of Transportation—Federal Aviation Administration
Supplemental Type Certificate
(Continuation Sheet)

Number SH3887NM

3. FAA approved Flight Manual Supplement for the 206H-990 windshield defroster system ("defroster only" system for rotorcraft with a non Air Comm Corp. bleed air cabin heater installation) in Bell Helicopter Models 206A, and 206B dated November 2, 1990, or later FAA approved revision is required.
4. FAA approved Flight Manual Supplement for the 206H-992/-994 windshield defroster system ("defroster only" system for rotorcraft with a non Air Comm Corp. bleed air cabin heater installation) in Bell Helicopter Models 206L, 206L-1 and 206L-3 dated November 2, 1990, or later FAA approved revision is required.
5. FAA approved Flight Manual Supplement for the 206H-201 bleed air cabin heater in Bell Helicopter Model 206B dated January 3, 1992, or later FAA approved revision is required.
6. FAA approved Flight Manual Supplement for the 206H-203 bleed air cabin heater in Bell Helicopter Model 206L-3 dated January 3, 1992, or later FAA approved revision is required.
7. FAA approved Flight Manual Supplement for the 206H-204 bleed air cabin heater in Bell Helicopter Model 206L-4 dated January 4, 1993, or later FAA approved revision is required.
8. FAA Approved Flight Manual Supplement for the 206H-204 Bleed Air Cabin Heater in Bell Helicopter Model 206L-4 with Tridair STC SR00036SE (Twin Engine), dated February 15, 1994 or later FAA approved revision is required.
9. This STC also applies to Bell Model 206L-4 with Twin Engines installed in accordance with STC SR00036SE.
10. This STC also applies to Bell Models 206A/B, and 206L helicopters with Allison 250-C20R/2 engine installed in accordance with STC SH4179NM and SH4169NM, respectively.
11. Approval of this change in type design applies to the above model aircraft only. This approval should not be extended to aircraft of this model on which other previously approved modifications are incorporated unless it is determined that the interrelationship between this change and any of those other previously approved modifications, including changes in type design, will introduce no adverse effect upon the airworthiness of that aircraft. A copy of this Certificate, Continuation Sheet, and FAA Approved Flight Manual Supplement or later FAA approved revision, must be maintained as part of the permanent records for the modified aircraft.

-----E N D-----

Any alteration of this certificate is punishable by a fine of not exceeding \$1,000, or imprisonment not exceeding 3 years, or both.

**Remove the following section
and retain with the
aircraft maintenance documents.**

**Air Comm Corporation
Boulder, CO. 80301**

SERVICE INSTRUCTIONS
FOR
BELL 206 A/B CABIN HEATER
(206H-201)
December 16, 1991

Introduction

This document provides maintenance and service information for the ACC 206H-201 Cabin Heater Installation in the Bell 206 A/B helicopter.

Reference Documents

1. Basic Bell Service Instructions.
2. AC43.13.1, Acceptable Practices, Aircraft Alteration and Repair.
3. ACC Drawings:

206H-201; Heater Installation General Arrangement
206H-503; Bleed Air Plumbing Installation (Standard)
206H-505; Bleed Air Plumbing Installation (NTH)
206H-526; Bleed Air Plumbing Installation (Hi-Output, "Arctic")
206H-800; Installation – Temperature Sensors
206H-904; Heater Ejector Installation (206 A/B Std & Hi-Output)
206H-905; Heater Ejector Installation (NTH)
206H-909; Heater Ejector Installation (206B Crashworthy Seat)
206H-986; Windshield Defroster Installation

System Description and Operation

The cabin heating system is a bleed air type which consists of bleed air plumbing, and a firewall shutoff valve, a heater control valve, and multiple heater ejectors.

The bleed air flows from the engine compressor through the bleed plumbing to the ejectors, where it is mixed with cabin air and exhausted to both the front and rear passenger areas. The ejectors are located under the front seat box area. The war air is ducted forward and aft through swivel outlets which are located in the seat box structure. The outlet flow of the pilot / co-pilot outlets can be individually adjusted by rotation of the swivel outlets.

The firewall mounted shutoff valve is electrically activated. The ON – OFF Switch is located in the overhead console. The firewall shutoff valve will automatically close if there is a loss of electrical power to the valve.

Temperature sensors are installed as part of the heater system. In the case of an over temperature condition, the sensors will close, resulting in the illuminations of an amber "heater over temp light, the automatic closure of the firewall shutoff valve. The heater ON – OFF switch must be re-set to the OFF position in order to reset the firewall shutoff valve and the heater over temp light. The heater control knob is located on the R/H front of the pilots seat box.

Continued

System Description and Operation (continued)

This system offers an optional defroster system which provides warm air to the windshield. The system consists of an ON – OFF valve located in the center console and ejectors in each defroster diffuser. The ejectors pump warm air across the windshield. The original defroster blowers are no longer required, but may remain installed at the discretion of the operator. The defroster and heater may be used simultaneously or independent of one another.

An automatic drain valve is also incorporated as a part of the heater system. This valve is used to drain cleaning solution overboard when washing the internal parts of the engine. This valve is located inside the L/H engine access door, and is automatically closed when the engine pressure rises above 10 psig.

Maintenance Instructions

Conduct the following inspection functions annually.

1. Inspect bleed air hose and tube assemblies for evidence of damage or deterioration. Replace as needed.
2. Verify operation of the warning light and firewall shut-off valve.
 - a. Air pressure (Shop or Bleed Air) must exist for firewall shutoff valve to operate.
 - b. Turn heater switch from off to on. (heater over temp should be off)
 - c. Using a heat gun carefully apply heat to one of the temperature sensors (do not exceed 200° F). Heater over temp light should come on, and firewall shut off valve should close. Remove heat source and allow area to cool.
 - d. After the temperature sensor has cooled, cycle heater switch from ON to OFF, and back to ON. The over temp light should again be off, and the heater firewall shutoff valve should again be open.
3. Inspect heater control valve for mounting security, and freedom of operation.
4. Inspect bleed air plumbing for insulation and security.
5. Verify security of control knobs and placards.
6. Check the function of the automatic drain valve to insure that the valve is closed when the engine is operating. CAUTION: this line is HOT, do not place hand on valve or line. Note: check valve when heater is in the "FULL ON" position. Slight leakage is permitted.
7. Remove the heater ejectors, inspect nozzles for evidence of deterioration. Check flow control (if equipped) for freedom of operation.
8. Verify operation of the "heater over temp" warning light (Press to test).

Continued

Maintenance Instructions (continued)

Suggested Spares:

| Item | Description | P/N | 206B Comm & NTH | 206 B Comm | 206B NTH | 206B Crashworthy Seat box |
|------|--------------------------------------|-------------|-----------------------|---------------|-------------|---------------------------------|
| 1 | Restrictor | S-9216EC-1 | 2 | | | |
| 2 | Hose Assy. – SS | S-9213EC-2 | 1 | | | |
| 3 | Y-Fitting | S-9266EC-21 | 1 | | | |
| 4 | Valve Assy. – Drain | S-9230EC-1 | 1 | | | |
| 5 | Valve Assy. – Control | S-9209EC-1 | 1 | | | |
| 6 | Valve Assy. – Control High Output | S-9264EC-1 | | 1 | | |
| 7 | Valve Assy. – Defroster | S-9209EC-3 | 1 | | | |
| 8 | Ejector Assy. (Fwd) | S-6450EC-1 | | 2 | | |
| 9 | Ejector Assy. (Aft) | S-6424EC-4 | | 2 | | |
| 10 | Ejector Assy. (Aft) | S-6452EC-2 | | | 1 | |
| 11 | Ejector Adaptor | S-9704EC-1 | | 4 | | |
| 12 | Ejector Adaptor | S-9704EC-2 | | | 2 | 2 |
| 13 | Ejector Assy. | S-6450EC-7 | | | 2 | 2 |
| 14 | Placard – Heater | S-9701EC-21 | | 1 | 1 | 1 |
| 15 | Placard – Heater High Output | S-9701EC-25 | | 1 | 1 | |
| 16 | Label – Heater Outlet | S-9722EC-1 | | 2 | 2 | 2 |
| 17 | Ejector Assy. Defroster L/H | S-9225EC-1 | 1 | | | |
| 18 | Ejector Assy. Defroster R/H | S-9225EC-2 | 1 | | | |
| 19 | Switch – Heater ON-OFF | MS24523-24 | | 1 | | |
| 20 | Sensor – Temperature | ES52130-1 | 4 | | | |
| 21 | Lens – Heater Over Temp (1) | S-9278EC-3 | 1 | | | |
| 22 | Valve – Firewall Shutoff | ES26185-1 | 1 | | | |
| 23 | Placard – Defroster | S-9868-2 | 1 | | | |
| 24 | Relay – Heater | WKJ-6D26.5V | 1 | | | |
| 25 | Switch Heater ON-OFF | MS24523-22 | | | 1 | |
| 26 | Circuit Breaker | MS22073-2 | 1 | | | |
| 27 | Ejector Assy. R/H Aft | S-6452EC-1 | | | | 1 |
| 28 | Ejector Assy. L/H Aft | S-6452EC-3 | | | | 1 |

(1) This item is an acceptable replacement for the factory supplied lens.

This area intentionally left blank

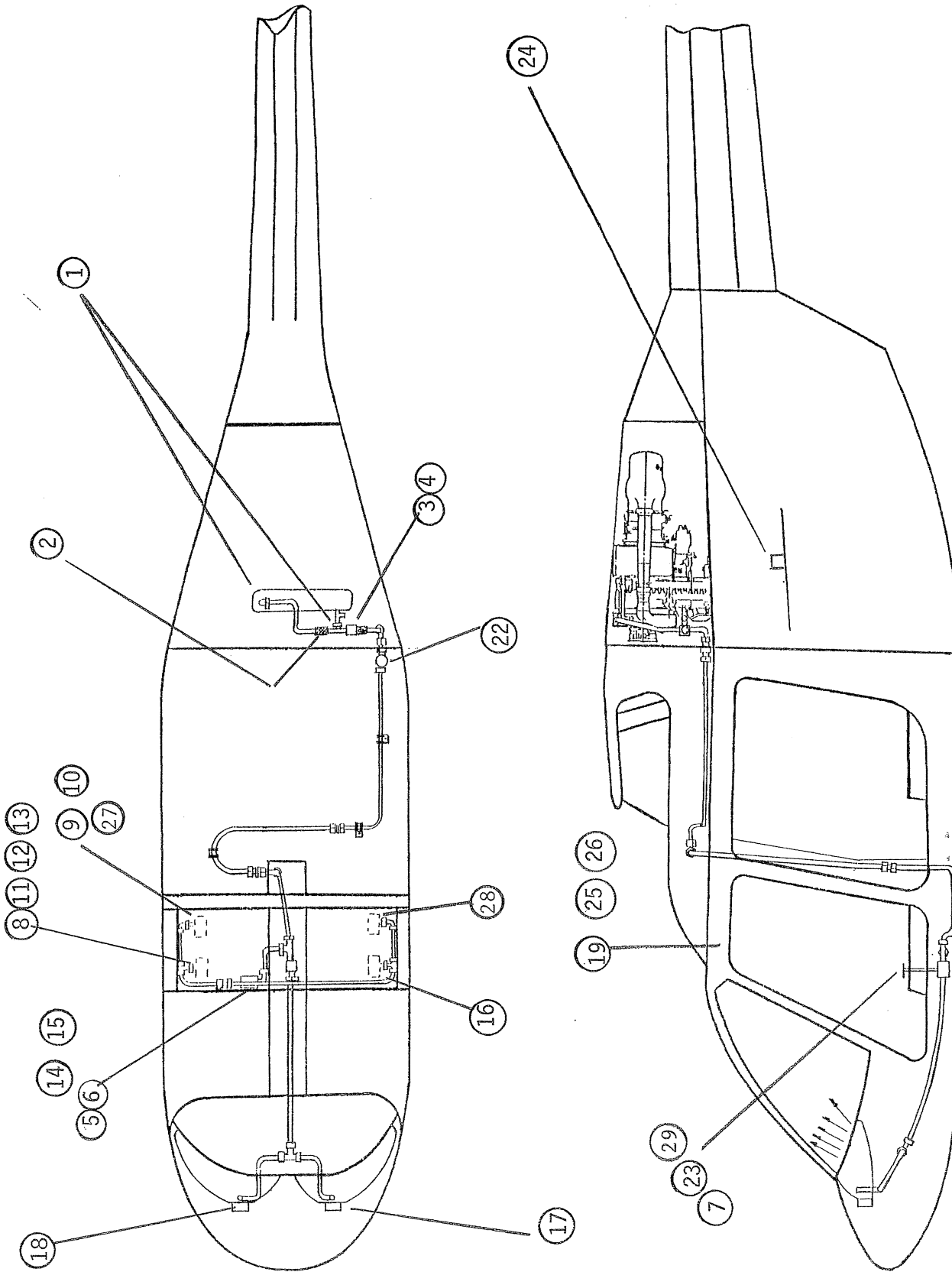
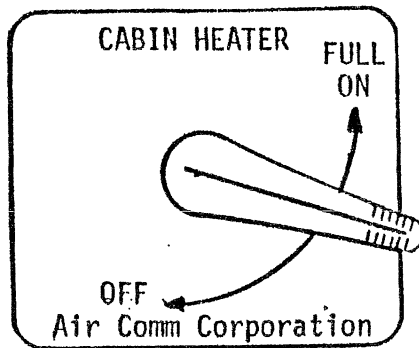
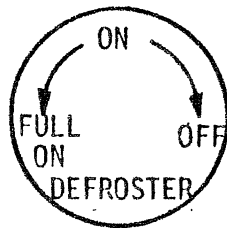

Figure 1. 206H-201 Cabin Heater Components



S-9701EC-21
Placard



S-9868-2
Placard

Figure 2. Heater and Defroster Control
Valve Placards

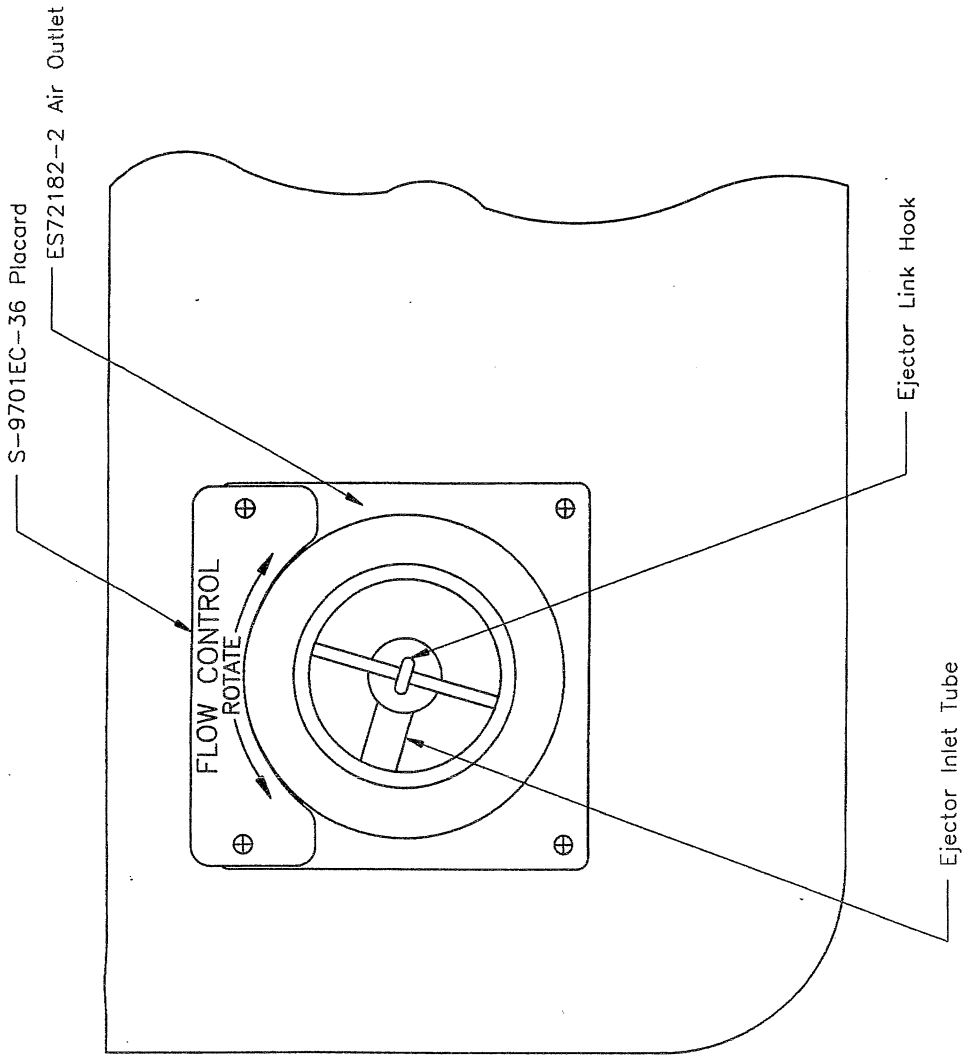
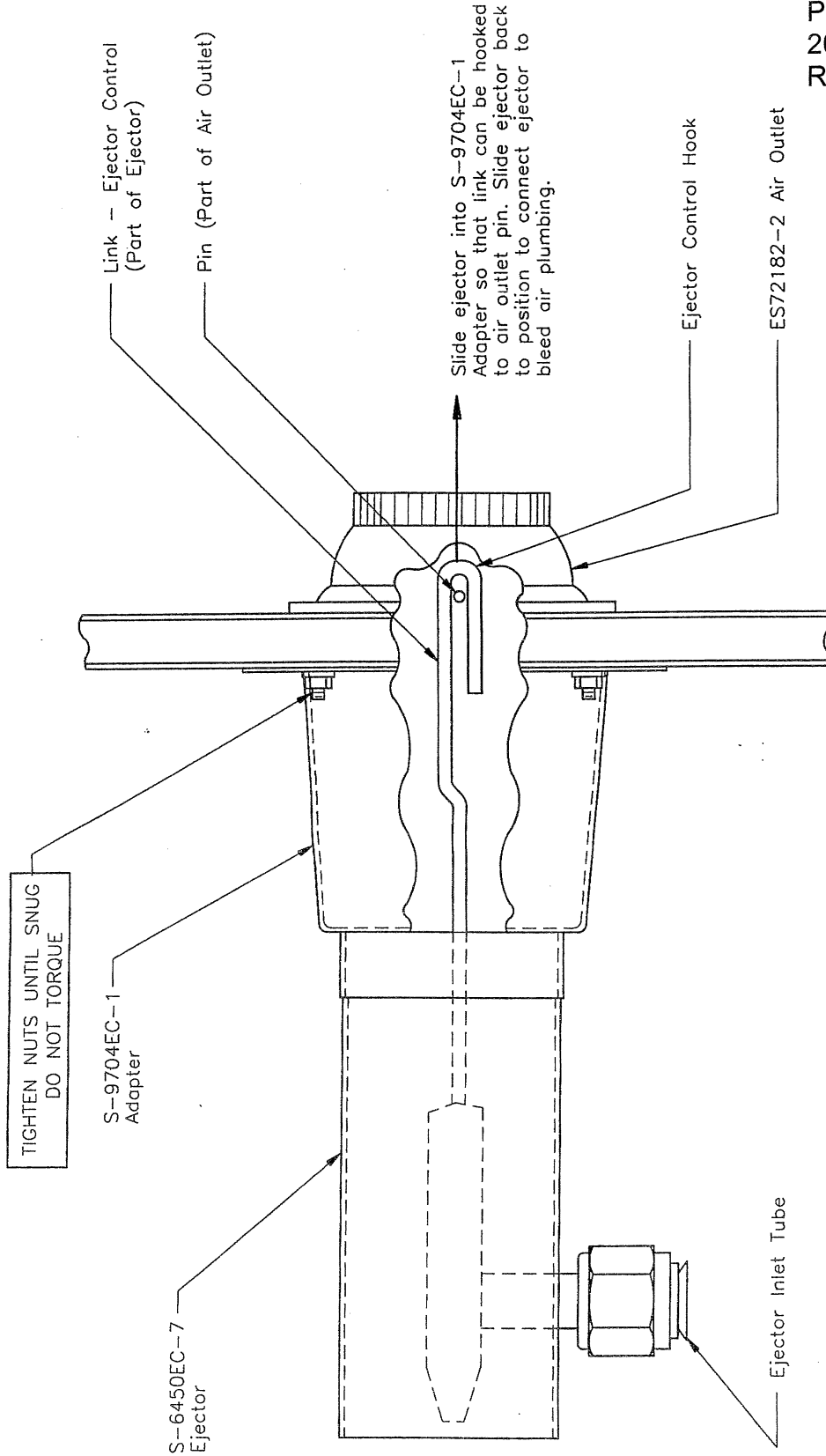

Figure 3. Heater Outlet Configuration

(forward outlets)



Heater Ejector Flow Control
Indexing Procedures

ASSEMBLY INSTRUCTIONS

1. Position slot in Flow Adjustment Bezel in vertical plane as shown.
2. Position flat portion of Flow Adjustment Rod in vertical plane as shown.
3. Insert Flow Adjustment Rod in slot of Flow Adjustment Bezel during assembly.

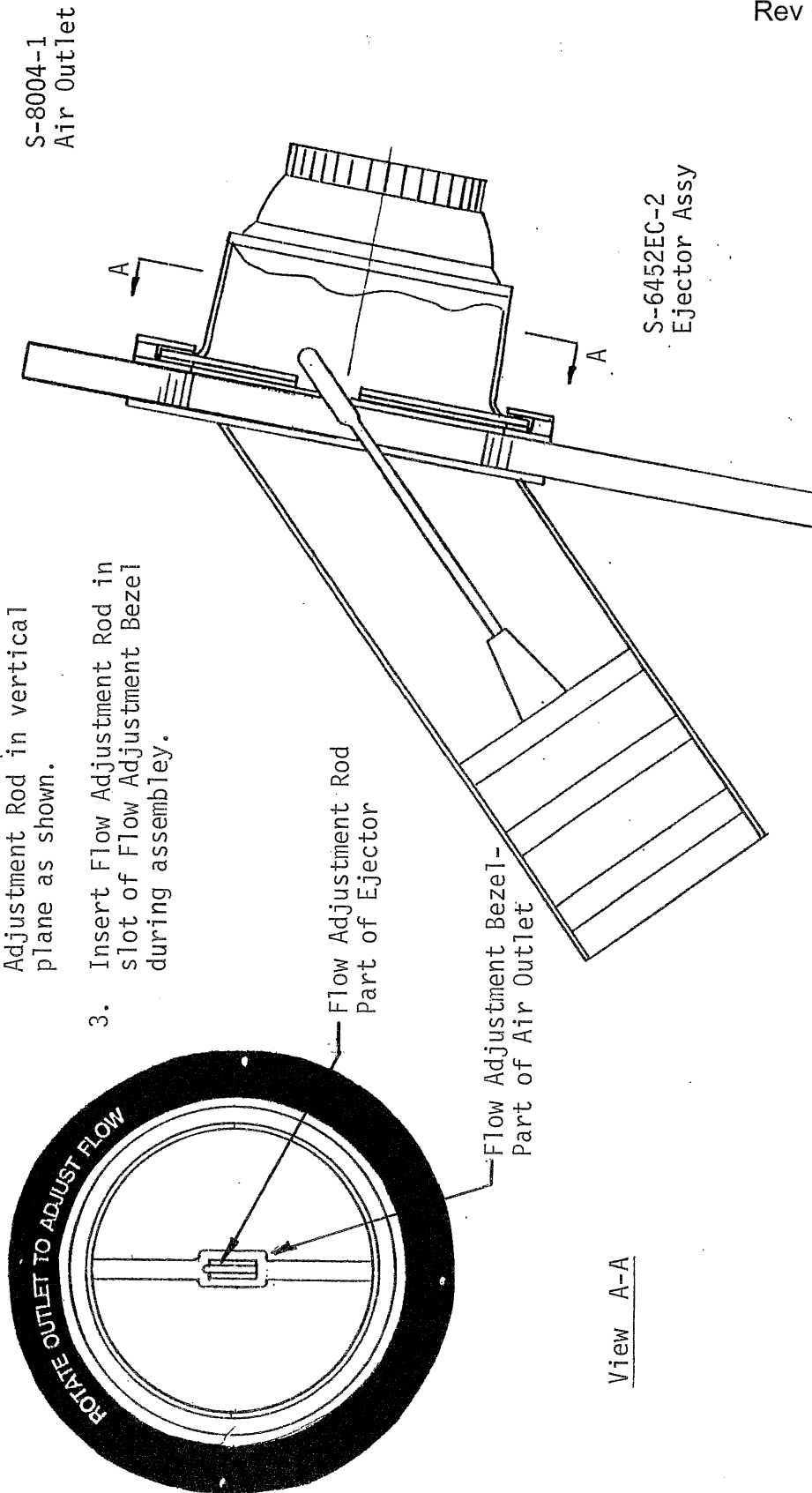

Figure 5. RH Rear Heater Ejector Indexing Procedure

Heater Switch

Heater Overtemp Light

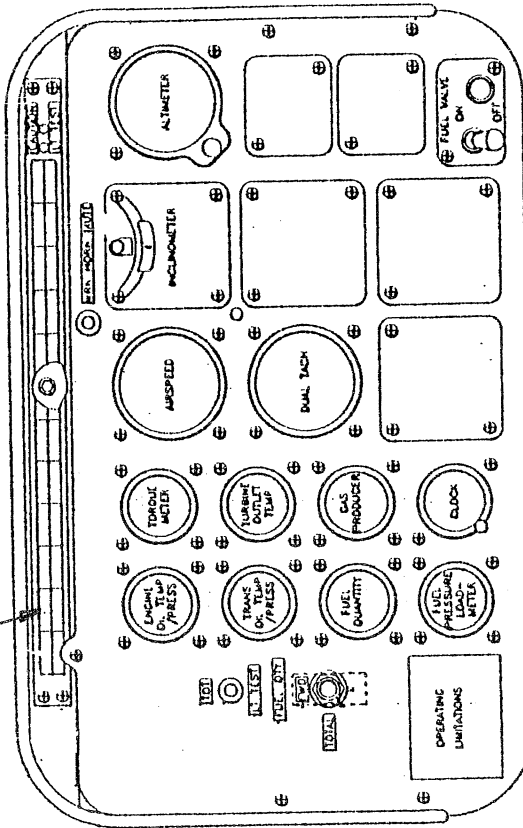
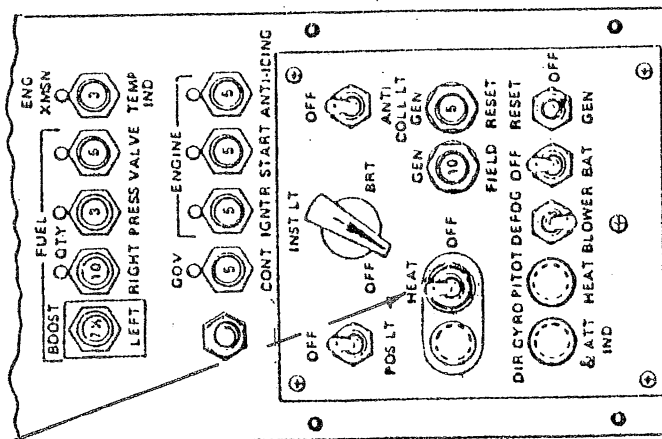

Figure 5: Overhead Console and Instrument Panel - Heater Hardware

(Applicable to 206B Comm)

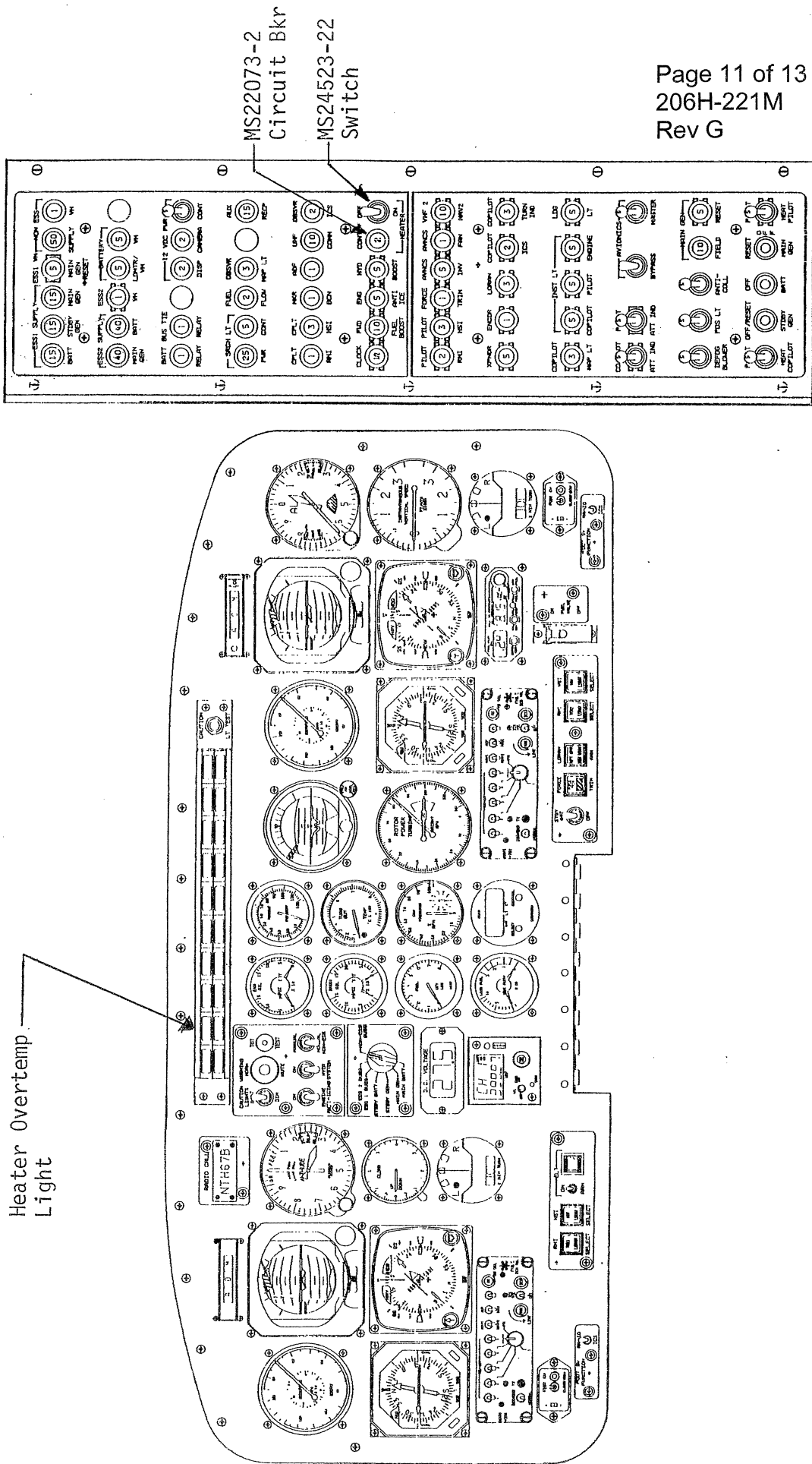

Figure 6. Overhead Console and Instrument Panel - Heater Instl

(Applicable to 206B NTH)

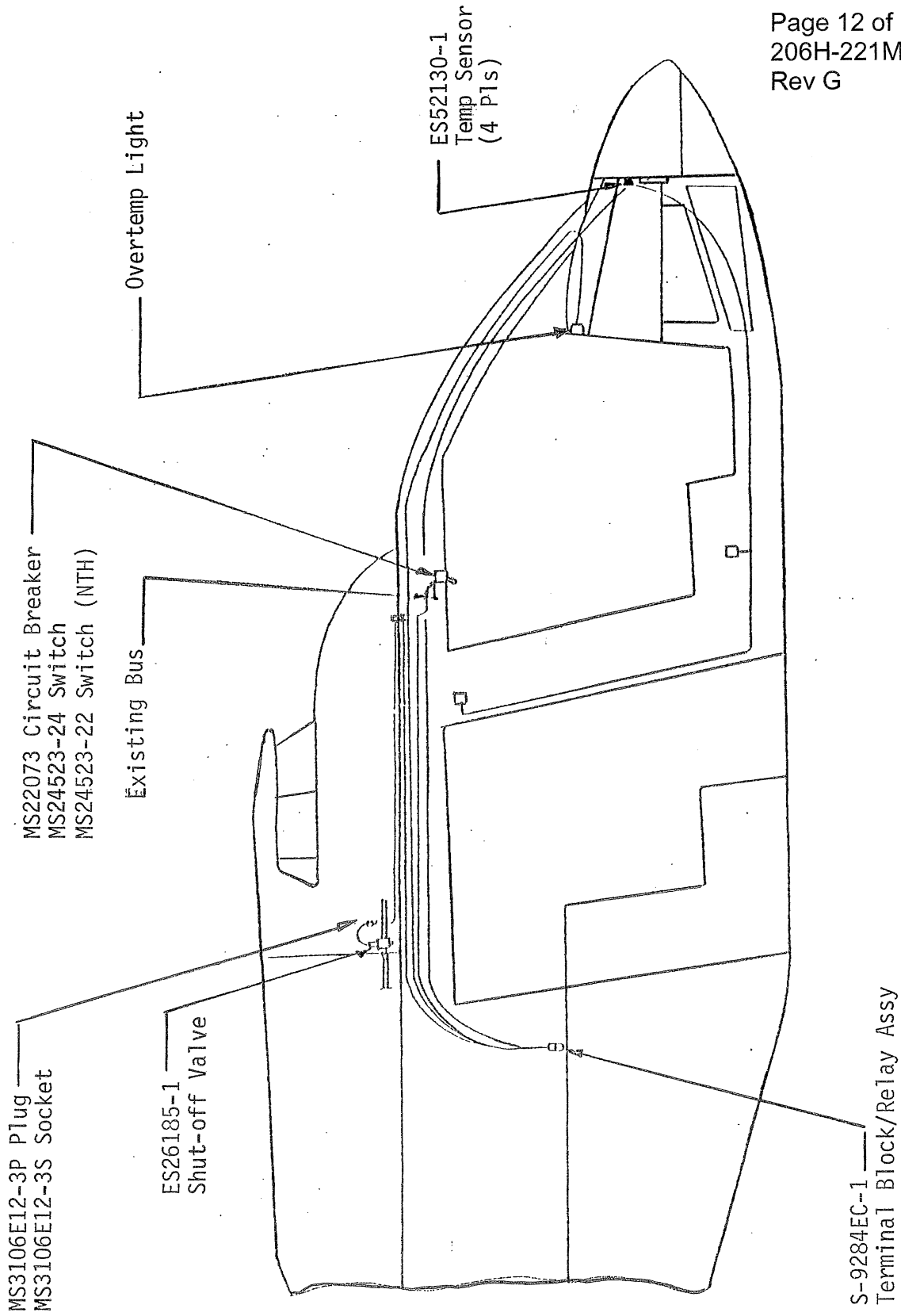

Figure 7. Electrical System Instl - Firewal1 Shut-off/Temp Sensors

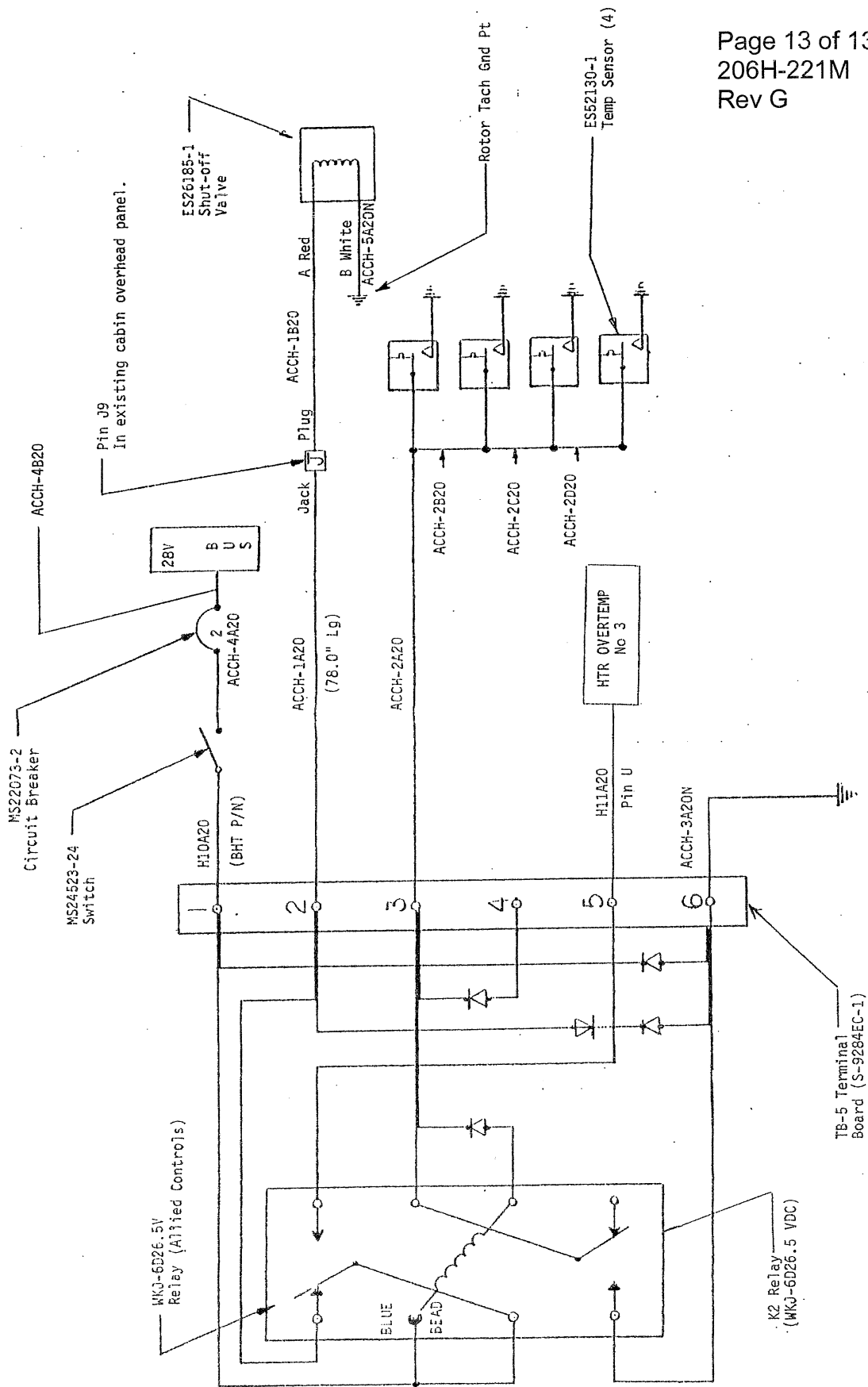

Figure 8. Electrical Schematic - Shut-off Valve/Temp Sensor Installation

WARRANTY

AIR COMM CORPORATION **Cabin Heating & Air Conditioning Systems**

Warranty Terms

Air Comm Corporation (hereafter referred to by ACC) warrants that products manufactured by ACC shall be free of defects in materials and workmanship for a period of one year from the date of purchase and / or 1000 hours of flying time whichever comes first.

Limitations and Exclusions

Installation, maintenance and operation of the product must be in accordance with the specifications and instructions provided by ACC. The warranty registration must be returned to ACC within 30 days of the date of installation.

This warranty shall not apply to any product repaired or altered by parties other than ACC unless express prior authorization is granted; nor shall this warranty apply to any product subjected to misuse or accident unless proof is submitted to the satisfaction of ACC that such misuse or accident was not a cause for the claimed defect.

The sole responsibility and liability of ACC and your exclusive remedy under any claim arising out of, connected with, or resulting from, this sale or the performance of breach of any condition of warranty thereunder, or from the manufacture, delivery, or use of the product shall be the rebuild or replacement of defective parts. Labor costs shall not be covered under any circumstances.

In no event, whether as a result of a breach of contract, warranty, tort (including negligence) or otherwise, shall ACC be liable for any special, consequential, incidental or penal damages or expenses including but not limited to loss of profit, goodwill, or revenues, loss of use of the equipment or any associated equipment, damage to associated equipment, cost of capital, cost of substitute products, facilities or services, down time, or cost or claims of third parties for such damages or expenses.

THE FOREGOING WARRANTY IS EXCLUSIVE AND IN LIEU OF ALL OTHER WARRANTIES OR REMEDIES WHETHER WRITTEN, ORAL, IMPLIED OR STATUTORY. ANY AND ALL IMPLIED WARRANTIES OR MERCHANTABILITY, FITNESS FOR A PARTICULAR PURPOSE, COURSE OF DEALING OR USAGE OF TRADE ARE HEREBY EXPRESSLY DISCLAIMED AND EXCLUDED.

Acceptance of the product by you shall constitute your acknowledgment and acceptance of the terms, provisions, limitations and exclusions set forth herein. Such terms, provisions, limitations and exclusions shall not be modified, deleted or supplemented except by an express written acknowledgment of ACC.

WARRANTEE PERFORMANCE: All claims under this warranty shall be made to ACC. All returned parts must be shipped prepaid for evaluation. Full details of the symptoms of the malfunction should be included to assist in the evaluation. Warranty credit or replacement will be extended only after ACC has determined that all conditions of this warranty have been met.

Air Comm Corporation
3300 Airport Road
Boulder, CO. 80301
Phone 303-440-4075
Fax 303-440-6355

Air Comm Corporation

Warranty Registration Form

NOTE:

Failure to complete and return this form to Air Comm Corporation within ten (10) days of the date of installation will render this warranty null and void.

Aircraft Model: _____ Serial Number: _____

Kit Serial Number: _____ Purchase Order No.: _____

Date of Installation: _____ Date Kit Received: _____

Product: (example Air Conditioner) _____

Part Number: (example 206H-200-2) _____

Total Time on Aircraft: _____

Submitted By: Installer _____

Contact Name: _____ Company Name: _____

Address: _____ City: _____

State: _____ Country: _____ Postal Code: _____

Phone Number: _____ Fax Number: _____

Email Address: _____

Contact Name: (if other than above) _____

Address: _____ City: _____

State: _____ Country: _____ Postal Code: _____

Phone Number: _____ Fax Number: _____

Email Address: _____

Mail To:
Air Comm Corporation
3330 Airport Road
Boulder, CO 80301

Phone: 303-440-4075

Fax 303-440-6355

Air Comm Corporation Malfunction Report

Submitted To:

Air Comm Corporation
3300 Airport Road
Boulder, CO. 80301
Attn: Service Manager
Phone No. 303-440-4075
Fax No. 303-440-6355

Date Reported or Claim Filled _____/_____/_____
Date Discrepancy Occurred _____/_____/_____

Submitted By: (Company Name, Address, Phone No.)

Submitted For: (Company Name, Address, Phone No.)

Phone Number _____

Phone Number _____

Fax Number _____

Fax Number _____

Person to contact _____

Person to contact _____

All warranty parts claims must be accompanied by the following information, failure to provide complete and accurate information will result in the warranty claim being disapproved.

Aircraft Data: (Please complete all sections)

| Model No. | Registration No. | Serial No. | Delivery Date | Total Hrs. at Delivery | Hrs. at Occurrence |
|-----------|------------------|------------|---------------|------------------------|--------------------|
| | | | | | |

Part Data: (Please complete all sections)

| Quantity | Part Number | Part Name | Serial No. (if available) | Hrs. at Occurrence |
|----------|-------------|-----------|---------------------------|--------------------|
| | | | | |

| | | |
|---|----------------|-------------------------------|
| Is this original equipment Yes No <small>(if no, please complete these two blocks) ▶</small> | Date Installed | Total A/C Hrs. when installed |
|---|----------------|-------------------------------|

Describe (in detail) of how the part failed, or reason for its return, (Please give any information that may be helpful in the evaluation of this part). _____

| |
|--|
| Warranty: <input type="checkbox"/> Approved <input type="checkbox"/> Disapproved |
|--|