

**AIR COMM CORPORATION**  
Boulder Municipal Airport  
3300 Airport Road  
Boulder, CO. 80301

**Report 206EC-230M**

**BELL 206A/B CABIN AIR CONDITIONING  
SYSTEMS INSTALLATION INSTRUCTIONS**

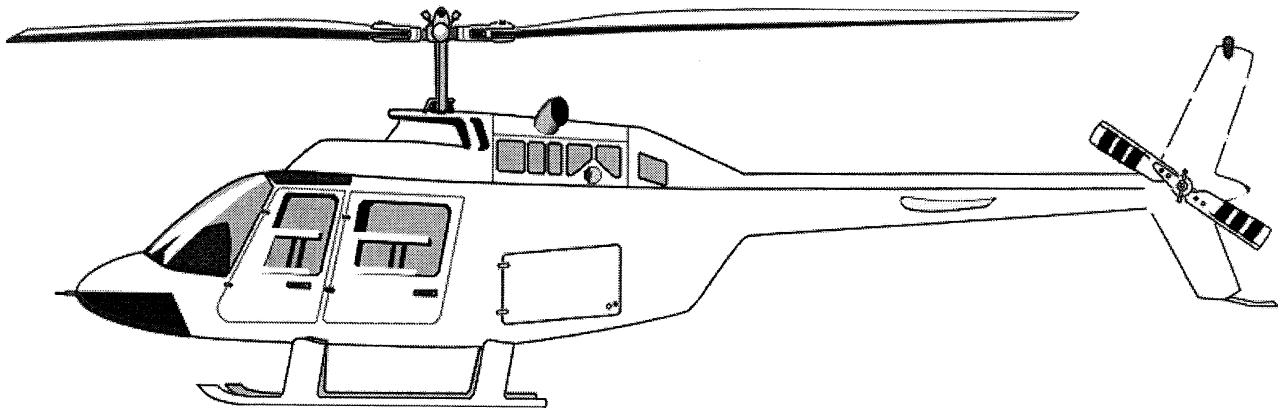

**This Document contains:**

**Flight Manual Supplement  
STC Certificate  
Service Instructions**

**September 6, 1994**

**Revisions**

<u>Rev</u>	<u>Date</u>	<u>Description</u>	<u>Appl</u>
A	12-01-94	Revised pgs 19 & 20 and added Pg 21 of Appendix A to incorp Latest configuration.	NS
B	12-15-97	Revised pg. II-1 to incorporate minor Wt. Corrections. Pg. 10 of 20: Removed Temp – Pressure charging data (see S-2506EC) Added note regarding tailrotor feedback.	NS

## Introduction

This document provides maintenance and service information for the ACC 206EC-200 Cabin Air Conditioning system installation in the Bell 206 A/B helicopter.

The drawings listed below are considered to be a part of this document.

## Reference Documents

1. Dwg 206EC-200 General Arrangement – 206 A/B Air Conditioner system.
2. Dwg 206EC-304 Compressor Installation.
3. Dwg 206EC-546 Plumbing Installation.
4. Dwg 206EC-626 Single Forward Evaporator Installation. (L/H Primary)
5. Dwg 206EC-629 Dual Forward Evaporator Installation.
6. Dwg 206EC-628 Aft Evaporator Installation.
7. Dwg 206EC-682 Air Distribution System.
8. Dwg 206EC-728 Condenser Installation.
9. Dwg 206EC-844 Electrical Installation.
10. AC43 . 13-1A Acceptable Practices, Aircraft Maintenance and Repair.
11. Bell Service Instructions Manual.

**Table of Contents**

<u>Item</u>	<u>Page</u>
Revisions	i
Introduction	1
References	1
Installation Instructions	I – 1
Weight & Balance Data	II – 1
Post Installation Check List	III – 1
Customer Feedback	IV – 1
STC Certificate	V – 1
Flight Manual Supplement	VI – 1
Appendix A	VII-1
Maintenance Instructions- Bell 206 A/B Air Conditioning System.	
Appendix B	
Warranty & Parts Return Procedure	VIII-1

**INSTALLATION INSTRUCTIONS**

## Installation Instructions

### General Arrangement

1. Disconnect battery, open engine cowling, remove the two (2) access panels on each side of the instrument console.
2. Remove the upper and aft baggage compartment panels.
3. Remove “hat rack” and aft cabin headliners.
4. Care should be taken to prevent contamination of the Air Conditioner system. All end plugs on all plumbing assemblies and system components should not be removed until the components are connected. If the system becomes contaminated, it must be flushed according to the procedures presented in Appendix A.

### Compressor Installation

Install in accordance with the installation instructions, drawing notes and information on the face of the drawing.

### Plumbing Installation

1. Thoroughly review drawing and drawing notes.

#### **Notice**

Install O-rings at all fittings. Apply light coat of Refrigerant oil to O-rings prior to installation. O-ring fittings should be torqued in accordance with the following torque chart. DO NOT OVER TORQUE!!

# 6 Fittings: 30 – 35 in/lbs.

#8 Fittings: 40 – 45 in/lbs.

#10 Fittings: 50 – 55 in/lbs.

2. Install system according to drawing requirements.
3. Check off all items on the drawing to insure that the installation is complete.

### Forward Evaporator Installation

Install in accordance with the installation instructions, drawing notes and information on the face of the drawing.

Installation instructions continued on next page.

Installation instructions continued:

Aft Evaporator Installation

Install in accordance with the installation instructions, drawing notes and information on the face of the drawing.

Air Distribution Installation

Install in accordance with the installation instructions, drawing notes and information on the face of the drawing.

Condenser Installation

Install in accordance with the installation instructions, drawing notes and information on the face of the drawing.

Electrical Installation

1. Thoroughly review drawing and all drawing notes.
2. Install system according to drawing requirements.
3. Check off all items on the drawing to insure that installation is complete.

**WEIGHT AND BALANCE DATA**

Correct aircraft empty weight and center of gravity as indicated below:

ITEM	Wt. (lbs)	Arm (in.)	Mom. (in-lbs)
<b>206 A/B Installation</b>			
206EC-200-9 Air Conditioner (Standard – one L/H Fwd. & one Aft. Evap)	83.68	133.4	11159
206EC-200-10 Air Conditioner (One R/H Fwd. & one Aft. Evap)	83.68	133.4	11159
206EC-200-11 Air Conditioner (Dual Fwd. & one Aft. Evap)	93.08	121.4	11304



**Post Installation Check List**

# POST AIR CONDITIONING SYSTEM INSTALLATION CHECK LIST

---

- \_\_\_ Confirmation of proper direction of rotation of Evaporator Blower Wheels.  
(See Electrical System Dwg.)  
**Note: Blower will work with blower wheel rotating in incorrect direction,  
But airflow will be significantly decreased, degrading system performance.**
- \_\_\_ Refrigerant Plumbing system oil charged. (See Plumbing Instl Dwg.)
- \_\_\_ Check Compressor hose routing and clamping to avoid hose kinking in the bend radius
- \_\_\_ Check Condenser Blower to insure that fan blade/housing clearing exist. Look for wear marks on inside of fan shourd. If rubbing exist contact Air Comm Corporation
- \_\_\_ Prior to charging the system, we recommend leak checking with dry nitrogen at (150 psi) using soap and water solution to bubble check connections.
- \_\_\_ Charge system according to instructions. If system is undercharged or overcharged the A/C will not work provide maximum cooling. For R-134a system, overcharging system will degrade performance more than slightly undercharging.
- \_\_\_ Leak check all joints after system charging, using an electronic leak detector\*. This is critical to insure continued optimum A/C performance. Use torque seal after torquing of joints and leak check has satisfactorily been performed.  
**\*Note: Using other than an electronic detector for final leak detection is unreliable and may allow some slow leaks to go undetected**
- \_\_\_ Check Evaporator air ducting to insure that :
  - \_\_\_ Ducts are securely clamped to duct connections
  - \_\_\_ Duct liner wire is in place to preclude collapse.
  - \_\_\_ Insure louvers are properly installed per drawing.
- \_\_\_ The Condenser Heat Exchanger rubber seal strip is properly positioned to insure a complete seal exist between the condenser heat exchanger and lower aft fuselage f airing. Inspect condenser inlet screen for proper security.
- \_\_\_ The three lightening holes located at the lower aft edge of baggage floor are properly sealed. (See Condenser Inst Dwg).
- \_\_\_ Insure proper alignment of compressor and tail rotor drive pulley. Check for proper belt tension per drawing, Inspect for correct mounting of compressor per drawing.

PLEASE RETURN CHECKLIST AND CUSTOMER FEED  
BACK FORMS TO HELP ACC MAINTAIN CUSTOMER  
SATISFACTION

**Customer Feedback**

# CUSTOMER FEEDBACK

In our ongoing effort to achieve complete Customer Satisfaction, Air Comm would appreciate your thoughts on our system whether it be a drawing clarification or an installation or suggestion. Please Fax this form back with your feedback. Thank You for your time.

**FAX TO :** Air Comm Corporation Engineering @ ( 303) 440-6355

**SYSTEM DESCRIPTION- CIRCLE ONE:**

**HTR / AC** 206A/B , 206L , 206LI , 206L3 , 206L4 , 206L4 LT

**DATE OF SYSTEM PURCHASE (APPROX.)** \_\_\_\_\_

**DWG NUMBER:** \_\_\_\_\_

**DATE OF DRAWING REVISION:** \_\_\_\_\_

**PAGE EFFECTED:** \_\_\_\_\_

**WHAT ARE THE COMPLAINTS** \_\_\_\_\_

---

---

---

---

---

---

---

---

---

---

**SUGGESTED CORRECTIVE ACTION:** \_\_\_\_\_

---

---

---

---

---

---

---

---

---

---

**YOUR NAME** \_\_\_\_\_ **ADDRESS** \_\_\_\_\_  
**POSITION** \_\_\_\_\_  
**COMPANY** \_\_\_\_\_ **PHONE** \_\_\_\_\_ **FAX** \_\_\_\_\_

**THANK YOU FOR YOUR FEEDBACK**

---

SUPPLEMENTAL TYPE CERTIFICATE

Department of Transportation—Federal Aviation Administration

# Supplemental Type Certificate

Number **SH2750NM**

This certificate, issued to **Air Comm Corporation**

certifies that the change in the type design for the following product with the limitations and conditions therefor as specified hereon meets the airworthiness requirements of Part 6 of the Civil Air Regulations.

Original Product—Type Certificate Number: H2SW  
 Make: Bell Helicopter Textron  
 Model: 206A, 206B, 206L, 206L-1, 206L-3, 206L-4

*Description of the Type Design Change:*

Installation of a freon type cabin air conditioning system with engine-driven compressor in accordance with Air Comm Corporation Drawing List DL-206AC, Revision 0, dated February 9, 1994, or later approved revision.

*Limitations and Conditions:*

1. FAA approved Rotorcraft Flight Manual Supplement for Bell Helicopter Models 206A and 206B with 250-C20, C20B, or C20J engines, dated May 12, 1986, or later approved revision is required.
2. FAA approved Rotorcraft Flight Manual Supplement for Bell Helicopter Models 206L, 206L-1 and 206L-3 with 250-C20B, C28B, or C30P engines and the model 206L with the 250-C20R/2 engine, in accordance with STC SH4169NM, dated July 5, 1988, or later approved revision is required.
3. FAA approved Rotorcraft Flight Manual Supplement for Bell Helicopter Model 206L-4 with 250-C30P engine, dated March 19, 1993, or later approved revision is required.
4. FAA approved Rotorcraft Flight Manual Supplement for Bell Helicopter Model 206L-4 modified in accordance with STC SR00036SE (Twin Engine), dated February 15, 1994, or later approved revision.
5. This STC also applies to Bell Model 206L-4 helicopters with twin engines installed in accordance with STC SR00036SE.
6. This approval should not be extended to rotorcraft of this model on which other previously approved modifications are incorporated unless it is determined that the relationship between this change and any of those other previously approved modifications, including changes in type design, will introduce no adverse effect upon the airworthiness of that rotorcraft.
7. A copy of this Certificate or later FAA approved revision, must be maintained as part of the permanent records for the modified aircraft.

*This certificate and the supporting data which is the basis for approval shall remain in effect until surrendered, suspended, revoked, or a termination date is otherwise established by the Administrator of the Federal Aviation Administration.*

Date of application: September 5, 1989

Date reissued: June 15, 1987

Date of issuance: October 4, 1989

Date amended: 7/7/88, 9/18/88, 4/19/93, 11/19/93, 2/15/94, June 4, 1997



*By direction of the Administrator*

ROGER P. CHUDY (Signature) Acting Manager  
 Denver Aircraft Certification Office  
 Northwest Mountain Region, Denver, Colorado  
 (Title)

Any alteration of this certificate is punishable by a fine of not exceeding \$1,000, or imprisonment not exceeding 3 years, or both.

This certificate may be transferred in accordance with FAR 21.47.

FLIGHT MANUAL SUPPLEMENT

206AC-200

Log of Pages

FAA APPROVED  
SUPPLEMENT

AIR COMM CORPORATION  
3300 AIRPORT ROAD  
BOULDER, COLORADO 80301

BELL HELICOPTERS  
MODEL 206A, 206B  
250-C20, C20B, C20J ENGINES

FLIGHT MANUAL SUPPLEMENT  
FOR  
AIR CONDITIONING SYSTEM

206AC-200

FAA APPROVED

The information contained in this document is FAA approved material, which must be carried in the basic Flight Manual, after the rotorcraft has been modified by installation of the Cabin Air Conditioning System in accordance with Air Comm Corporation STC No. SH2750NM.

The information in this document supplements or supercedes the basic manual only in the items contained herein. For limitations, Procedures, and Performance Data not contained in the supplement, consult the basic flight manual.

MODEL 206A, 206B  
FLIGHT MANUAL

CABIN AIR CONDITIONING SYSTEM

Log of Pages		
Original .....	0	
Pages	Rev No.	Pages
1-8	0	
1, 3	1	
1, 3	2	
5	3	
1, 4, 5	4	
1-8	5	
FAA APPROVED DATE: May 12, 1986 APPROVED: <i>Bergel H. Meyers III</i> for Woodford R. Boyce Denver A/C Certification Office Northwest Mountain Region Aurora, Colorado		

FAA APPROVED 5-12-86

Revised: 5/15/86

REVISED: 6/12/87

1 OF 8  
APR 23 1992

REVISED:

FAA APPROVED 5-12-86

2 of 8



MODEL 206A, 206B  
FLIGHT MANUAL

MODEL 206A, 206B  
FLIGHT MANUAL

CABIN AIR CONDITIONING SYSTEM

CABIN AIR CONDITIONING SYSTEM

Log of Revisions

No.	Rev Date	Pgs Revised	FAA Appl
0		Original Issue	
1	5-15-86	1 & 3	<i>Karys/Mayer-III</i>
2	6-12-87	1 & 3	<i>D.J. T. Guman</i>
3	6-22-89	5	<i>M.H. Portie</i>
4	APR 23 1992	Revised pgs 1, 4 & 5.	<i>R.E. Junip</i>
5	9-19-01	3 & 5	<i>D-26</i>

Note: Revisions are indicated by a black vertical line. Insert latest revision pages; dispose of superseded pages.

INTRODUCTION

The cabin air conditioning system is a vapor cycle type which consist of engine driven compressor, a condenser, and multiple evaporators.

The function of the compressor is to pump refrigerant throughout the system circiit.

The function of the condenser it to remove heat energy from the refrigerant by forcing outside air across the condenser heat exchanger.

The function of the evaporators is to remove heat and moisture from the cabin, by forcing cabin air across the evaporator heat exchangers.

The system controls consist of a switch which can be positioned to AC, BLOWER, or OFF. In the AC mode, the complete cooling system is activated. In the BLOWER mode, only the evaporator blowers are operating as a means of cabin air circulation.

A HI/LO blower speed switch is located at each evaporator outlet, for individual airflow adjustment.

Window defogging can be accomplished by simultaneous operation of the air conditioner and the cabin heater. For this case the performance degradation of both the heater and the air conditioner is additive.

Revised: 6/22/89

FAA APPROVED 5-12-86

REVISED: APR 23 1992

Revised SEP 19 2001

CABIN AIR CONDITIONING SYSTEM

SECTION I

OPERATING LIMITATIONS

PLACARDS AND MARKINGS

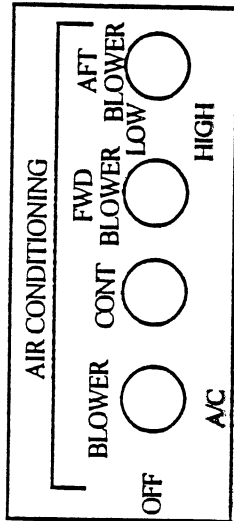

Located in overhead console. Alternate location in lower center console.

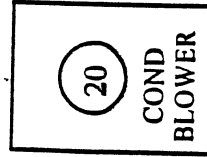
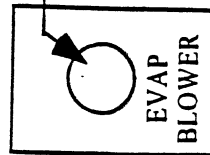
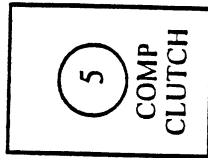
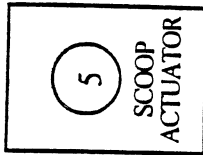

Circuit breaker labels located on lower surface of top panel of baggage compartment, adjacent to circuit breakers.

FAA APPROVED 5-12-86  
REVISED 6/22/89  
REVISED APR 23 1992  
~~SEP 19 2001~~

CABIN AIR CONDITIONING SYSTEM

SECTION I (Cont'd)

OPERATING LIMITATIONS

PLACARDS AND MARKINGS

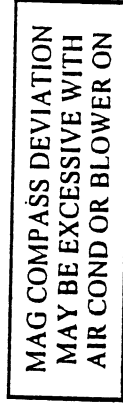

Locate on top of compass support bracket.

SECTION 2

NORMAL PROCEDURES

PREFLIGHT CHECK (EXTERIOR)

Compressor - check security.  
Compressor drive belt - check tension and general condition.  
Condenser - check security.

ENGINE PRESTART CHECK

A/C Switch - OFF

BEFORE TAKEOFF

A/C ON as desired.  
Select HI/LO blower as desired.

IN FLIGHT OPERATIONS

A/C ON as desired.  
Select HI/LO blower as desired.

DESCENT AND LANDINGS

A/C ON as desired.  
Select HI/LO blower as desired.

MODEL 206A, 206B  
FLIGHT MANUAL

CABIN AIR CONDITIONING SYSTEM

SECTION 3                      EMERGENCY PROCEDURES

Operate air conditioner switch to - OFF, for any of the following emergencies:

- Engine Failure
- Engine Overtemperature
- Fuel Control and/or Governor Failure
- Insufficient Power

SECTION 4                      MALFUNCTION PROCEDURES

Lack of cooling may be an indication of loss of refrigerant. If outlet air is not cool, turn A/C to OFF, or to BLOWER to preclude damage to the compressor.

MODEL 206A, 206B  
FLIGHT MANUAL

CABIN AIR CONDITIONING SYSTEM

SECTION 5                      PERFORMANCE DATA

When the A/C is operating, the performance data in the basic flight manual should be reduced as shown below:

- Rate of Climb - Reduce FM data by 78 Ft/min.
- Hover Ceiling - Add 64 lbs. to the actual A/C weight and read the reduced hover ceiling from the FM data. Extrapolate curves if operating at the aircraft maximum gross weight.

**Maintenance Instructions**

**AIR COMM CORPORATION  
Boulder Municipal Airport  
3300 Airport Rd.  
Boulder, CO. 80301**

**Document No. 206EC-230M**

**MAINTENANCE INSTRUCTIONS  
BELL 206 A/B AIR CONDITIONER SYSTEM  
For System Installation  
206EC-200-9,-10,-11**

**R134a system**

**September 3, 1994**

Table of Contents

Introduction	3
Reference Documents	3
System Description and Operation	4
Suggested Spares List	5
Safety Procedures	6
Tools, Equipment, and Consumables	7
Lubrication	8
Receiver Drier Bottle	8
Plumbing Fittings	8
Belt Replacement and Adjustment	8
System Leak Check	9
System Charging	10
System Troubleshooting	11
Periodic Inspections and Overhaul Schedule	13
Drawings:	
General Arrangement	14-15
Electrical System	16
Electrical Schematic	17-19
Drive Pulley Installation	20

## Introduction

This document provides maintenance and service information for the ACC 206EC-200 Cabin Air Conditioning system installation in the Bell 206 A/B Helicopter.

The drawings which are listed below are considered to be part of this document.

## Reference Documents

1. Dwg 206EC-200 General Arrangement - 206 A/B Air Conditioner system.
2. Dwg 206EC-304 Compressor Installation.
3. Dwg 206EC-546 Plumbing Installation.
4. Dwg 206EC-626 Single Forward Evaporator Installation. (L/H Primary)
5. Dwg 206EC-629 Dual Forward Evaporator Installation.
6. Dwg 206EC-628 Aft Evaporator Installation.
7. Dwg 206EC-682 Air Distribution System.
8. Dwg 206EC-728 Condenser Installation.
9. Dwg 206EC-844 Electrical Installation.
10. AC43 . 13-1A Acceptable Practices , Aircraft Maintenance and Repair.
11. Bell Service Instructions Manual.

### System Description and Operation

The 206EC-200 system is a vapor cycle type Air Conditioner consisting of a Compressor, Condenser, Dryer, By-pass valve, and Multiple Evaporator assemblies.

The Compressor is belt driven off of the tail rotor drive shaft, which is located in the engine compartment.

The Condenser assembly is located below the baggage compartment floor. Cooling air is forced through the condenser by a 28V DC electric blower, and an electrically actuated scoop that opens and closes when the system is switched from OFF to ON to OFF.

Each evaporator assembly contains a 28V DC, two speed electric blower that allows the system to be switched to either a High or Low setting.

A refrigerant gas by-pass valve is located aft of the baggage compartment. The purpose of this valve, (which is set at the factory) is to prevent evaporator heat exchanger freeze-up by controlling the minimum evaporator pressure (temperature).

The system incorporates a binary high/low pressure "cut-out" switch. This switch is intended to protect the compressor in case of system over-pressure or loss of refrigerant. The switch is located adjacent to the system charging ports ( Aft of the baggage door on the L/H side of the aircraft) and is wired in series with the compressor clutch.

Switch operating pressures:

- Low Pressure function –  
Open @ 30 psi  
Close @ 50 psi
- High Pressure function –  
Open @ 335 psi  
Close @ 280 psi



Suggested Spares List

<u>Item</u>	<u>Part Number</u>
Forward & Aft Evaporator Blower Motor	ES61060-2
Condenser Blower	ES73186-1
Compressor	S-3008EC-6
Compressor Drive Belt	7255
Relay – Control	W389DCX-3
Relay – Evaporator	W389CX-8
Relay – Condenser	W389CX-13
Receiver Drier Bottle	800-1179
Binary Hi/Lo Pressure Switch	ES57008-2
Circuit Breaker (1 Amp)	MS26574-1
Circuit Breaker (5 Amp)	MS26574-5
Circuit Breaker (15 Amp)	MS26574-15
Circuit Breaker (20 Amp)	MS26574-20
Resistor – Fwd Evaporator	F30J3RO
Resistor – Aft Evaporator	D100K3RD

### Safety Precautions

The refrigerant used in the air conditioning system is HFC R134a. This refrigerant is non-explosive, non-flammable, non-corrosive, has practically no odor, and is heavier than air. Although R134a is classified as a safe refrigerant, certain precautions must be observed to protect parts involved and the person(s) working on the system.

Liquid R134a at normal atmospheric pressure and temperature evaporates so quickly that it will freeze anything that it contacts. Care must be taken to prevent any liquid refrigerant from coming in contact with the skin, especially the eyes. R134a is readily absorbed by most types of oil, therefore it is recommended a bottle of clean mineral oil and weak solution of boric acid be kept nearby when servicing the refrigerant system.

### **CAUTION**

Always wear safety goggles when servicing any part of the refrigerant system. Should any liquid refrigerant get into the eyes, use a few drops of mineral oil to wash them out, then use a weak solution of boric acid to wash eyes, and seek aid from a doctor immediately even though the irritation has ceased.

It is important to keep the system tightly sealed because the refrigerant system is always under pressure. Heat applied to any part of the system will cause the pressure to build up excessively.

### **CAUTION**

To avoid explosion, never weld, use a flame-type leak detector, blow torch, solder, stem clean, bake on aircraft finish, or use excess amounts of heat on, or in the immediate area of any part of the air conditioning system or refrigerant supply tank, while they are closed to the atmosphere.

Tools, Equipment, and Consumables

1. Service Equipment: (Suggested)  
Recovery / Recycling / Recharging Station-

Robinair Model 34700 or Equivalent  
Montpelier, OH  
1-800-822-5561

2. Electronic Leak Detector: (Suggested)

Micron – Tech III or Equivalent  
Model 209907  
Murray (NAPA)

3. O-ring:

**CAUTION**

This system is charged with R134a  
Refrigerant and must be fitted with  
HSN O-rings (green in color).

3. Lubricant:

**CAUTION**

This system is charged with R134a  
Polyester Refrigerant Oil.  
DO NOT USE OTHER  
LUBRICANTS. Source: ICI America,  
Wilmington, DE. (1-800-822-8215)

4. Refrigerant:

DuPont HFC R134a

### Lubrication

The total air conditioning system oil charge is  $7.5 \pm .5$  oz., The compressors are factory charged with 3.5 oz. of oil. An additional 4 oz. of oil should be added to the discharge line prior to system charging.

Care should be taken to avoid spilling any of the compressor oil charge during installation. If this should occur, drain the oil and recharge the 3.5 oz.

The oil charge is continuously circulated by the refrigerant while the system is operating. If the system charge is reclaimed, or if a sudden loss of refrigerant occurs, a significant amount of oil will be removed from the system. An attempt must be made to determine the amount of lost oil. Generally, the amount lost is approximately 4 oz., this amount should be added for sudden loss of refrigerant. If reclaiming refrigerant, check the amount of oil removed from the system by the reclaiming machine and replace when recharging.

### **WARNING**

Inadequate oil or refrigerant in the system can result in compressor "Lock-Up" and require replacement of the compressor.

### Receiver Drier

The receiver drier is the system reservoir and is located adjacent to the charging ports. The drier bottle contains a desiccant filter (silica gel) which serves to absorb moisture from the system.

### **NOTE**

To preclude saturation of the desiccant, the drier line caps should not be removed until just prior to evacuation and charging of the system. The drier bottle should be replaced when ever the system is suspected of being contaminated with moisture.

### Refrigerant Fitting Assembly Instructions

A light coat of refrigerant oil should be applied to all O-rings prior to assembly.

O-ring fittings should be tightened sufficiently to slightly compress the O-ring (Excessive Torque Will Damage the Fitting). See O-ring installation instructions on the following Page.

### Belt Replacement and Adjustment

To replace the compressor drive belt it is necessary to remove the tail rotor drive shaft segment between the engine transmission and the air conditioner drive pulley. (see BHT Service Manual).

Proper belt tension is important to insure a long belt service life and to avoid excessive side load on the tailrotor driveshaft bearing.

The proper belt tension is achieved as shown below:

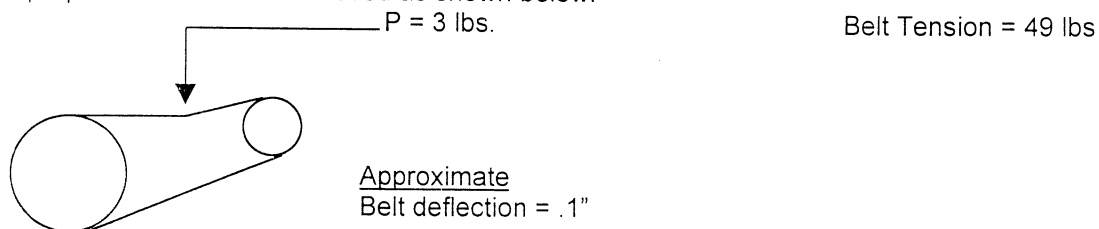

Add force of 3 lbs to midpoint of belt span. Belt with correct tension should deflect .1 inch at the mid point of belt span.

**RESET BELT TENSION AFTER TWO HOURS OF OPERATION OF NEW BELT.**

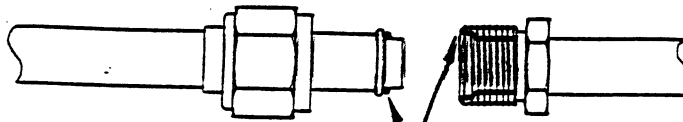

Apply refrigerant oil to O-ring and female side of fitting.  
Confirm there is no damage / nicks or dirt on fittings  
Slide B-nut back away from end of tube so you may see o-ring as you slide the fitting together.

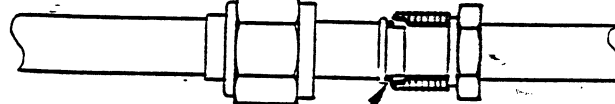

Be careful not to pinch O-ring.

Engage male end into female fitting being very careful to maintain alignment and not pinch O-ring during this step.

The male flange should seat fully against the metal side of the female flange without the O-ring being pinched between.

Hold fitting together while sliding B-nut forward and engaging threads. Tighten B-nut, and torque to the following settings.

#6 Fittings: 30-35 in lbs **Do not over torque**  
#8 Fittings: 40-45 in lbs  
#10 Fittings: 50-55 in lbs

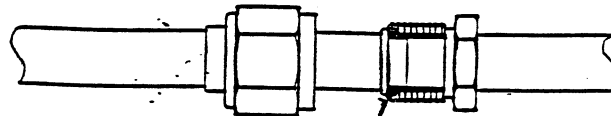

Female fitting should seat against metal of male fitting.

Once system is charged, check each fitting with an electronic leak detector. (an Electronic Leak Detector is the only reliable method of checking for refrigerant leaks)  
Once fittings have been checked and are leak free, Torque Seal as appropriate.

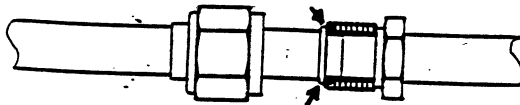

Be careful not to misalign fittings as they are placed together

System leak check

Identification of and elimination of any system fitting leaks is extremely important to insure a trouble free system.

A system which contains a partial charge can be leak tested and recharged without evacuating the system. The system can be pressurized with nitrogen or R134a refrigerant. A system which has been evacuated should be filled to a pressure of at least 50 psig of refrigerant or 150 psi nitrogen prior to the leak survey.

### System Leak Check (cont)

The system should be leak tested using an electronic leak detector. Initial leak check can be accomplished with a refrigerant charge of .5 lbs and the electronic leak detector. Each fitting should be checked and repaired prior to the final charging process.

**Do not use compressed air for the pressure check!** Compressed air can introduce moisture in the system which will cause it to operate poorly or not at all. Take your time, and check all around each fitting. A little extra time during the leak check will save a significant amount of time later during servicing or troubleshooting.

All leak checks should be conducted with the air conditioner "off". Since the refrigerant is heavier than air, leaks are most likely detected on the underside of hoses and fittings. Also the refrigerant will collect in low areas and provide an erroneous leak indication. A stream of "shop air" through a nozzle is useful in clearing an area just before checking for leaks.

If a leak is detected at an O-ring fitting, reclaim the system and install a new O-ring. Lubricate the O-ring with refrigerant oil prior to installation.

A small amount of leakage (one once per year) past the compressor seal is normal. Most leak detectors are sensitive enough to show a leak of this magnitude.

### Charging Procedure

- NOTE – This system should be serviced by **QUALIFIED PERSONNEL** only!
- 1. Leak check system in accordance with procedures present on pages 9 and 10.
- 2. Evacuate system for a minimum of 30 minutes.
- 3. Charge the system with 2.4 lbs (single fwd. Evaporator) or 2.6 lbs (Dual fwd. Evaporator) of R134a refrigerant. System pressures can vary depending on temperature / humidity relationships. The **most accurate** method of charging a system is to add an initial refrigerant charge of 2.0 lbs then continue to add refrigerant until the evaporator outlet air temperature and system suction pressure reaches a minimum and subsequently starts to increase. When adding the refrigerant after the initial charge it should be done in increments of .25 lbs, and a minimum of 10 minutes allowed to elapse before adding each additional .25 lbs of refrigerant charge. This allows the system to stabilize and reach its maximum cooling potential for the given charge. The optimum charge occurs when evaporator outlet air temperatures are at their lowest. Any additional refrigerant will cause the outlet air temperature to increase and system performance to be degraded. Charge the system to the point of noticing the first temperature increase, then reduce charge back to the optimum point where outlet air temperatures were lowest.

### Refrigerant Pressure

System pressures will vary due to temperature and humidity relationships.

#### **NOTE**

**System overcharging, or operation of system during low ambient conditions may result in tailrotor pedal feedback!**

## System troubleshooting

Prior to troubleshooting a defective system, conduct a visual inspection for general condition. Inspect condenser fins for damage, comb out bent fins, and Check circuit breakers in baggage compartment.

The following step-by-step procedures lists the easiest checks, and most likely problem sources, first.

### 1. Electrical

With the engine off turn switch to “Blower” and make sure all evaporator blowers operate in both Hi and Low modes. Pull evaporator circuit breaker in battery compartment, and turn switch to A/C. Check that the condenser blower and actuator assy. Is working, and the compressor clutch is engaging.

### 2. System Charge

(See page 10, “Charging Procedures” )

### 3. Expansion Valve Malfunction

If the cooling loss is limited to only one evaporator, it is most likely a defective expansion valve.

Loss of cooling in all evaporators (assuming that there were no problems identified during steps 1 or 2) could be caused by refrigerant flow blockage at the expansion valves. This blockage could be due to ice or dirt.

Replacement of the drier bottle and a thorough system evacuation might be a fix (remove the possibility of ice at the expansion valve nozzles).

### 4. Compressor Malfunction

If the system will not maintain the pressures and there are no system leaks, the problem could be a failed compressor. The compressor must then be replaced.

System Troubleshooting

Problem	Cause	Solution
1. Premature Belt Failure	<ul style="list-style-type: none"> <li>a. Belt too loose</li> <li>b. Compressor misalign.</li> <li>c. System over charged</li> </ul>	<ul style="list-style-type: none"> <li>a. Adjust belt tension</li> <li>b. Re-install/align compressor</li> <li>c. Adjust system charge</li> </ul>
2. Condenser blower motor Circuit Breaker "Pops"	<ul style="list-style-type: none"> <li>a. Probable cause- Overheating of condenser blower motor</li> </ul>	<ul style="list-style-type: none"> <li>a. Check for loose or rubbing of fan blade, or possible replacement of motor</li> </ul>
3. Water (Condensate) in area of the aft evaporator	<ul style="list-style-type: none"> <li>a. Condensate drain fitting on evaporator not sealed</li> <li>b. Evaporator housing not sealed</li> <li>c. Drain line / check valve not installed properly</li> <li>d. Condensate forming on plumbing fittings</li> </ul>	<ul style="list-style-type: none"> <li>a.b.c. Verify that installation conforms to drawing requirements. (remove evaporator inlet duct, and pour 1/2 ltr. of water into housing assy. To check for leaks &amp; drainage.</li> <li>d. apply cork insulation to all exposed refrigerant lines.</li> </ul>
4. Water in chin bubble area of forward evaporator	<ul style="list-style-type: none"> <li>a. Forward evaporator housing not sealed</li> <li>b. Condensate drain line fittings not secure at evaporator connection.</li> <li>c. Drain line check valve not installed</li> </ul>	<ul style="list-style-type: none"> <li>a. Same as problem #3</li> <li>a.b.c.</li> </ul>
5. Conditioned air outlet louvers broken / loose		<ul style="list-style-type: none"> <li>a. Replace Louvers</li> </ul>
6. Evaporator Coil freeze up	<ul style="list-style-type: none"> <li>a. System suction pressure (temperature) too low. System suction pressure should not be below 20 psi.</li> </ul>	<ul style="list-style-type: none"> <li>a. Adjust system charge to 25 - 32 psi.</li> </ul>
7. System not Cooling	<ul style="list-style-type: none"> <li>a. Loss of refrigerant</li> <li>b. Water in system</li> </ul>	<ul style="list-style-type: none"> <li>a. Evacuate system, leak check and recharge.</li> <li>b. Evacuate system, replace receiver drier bottle, &amp; recharge</li> </ul>





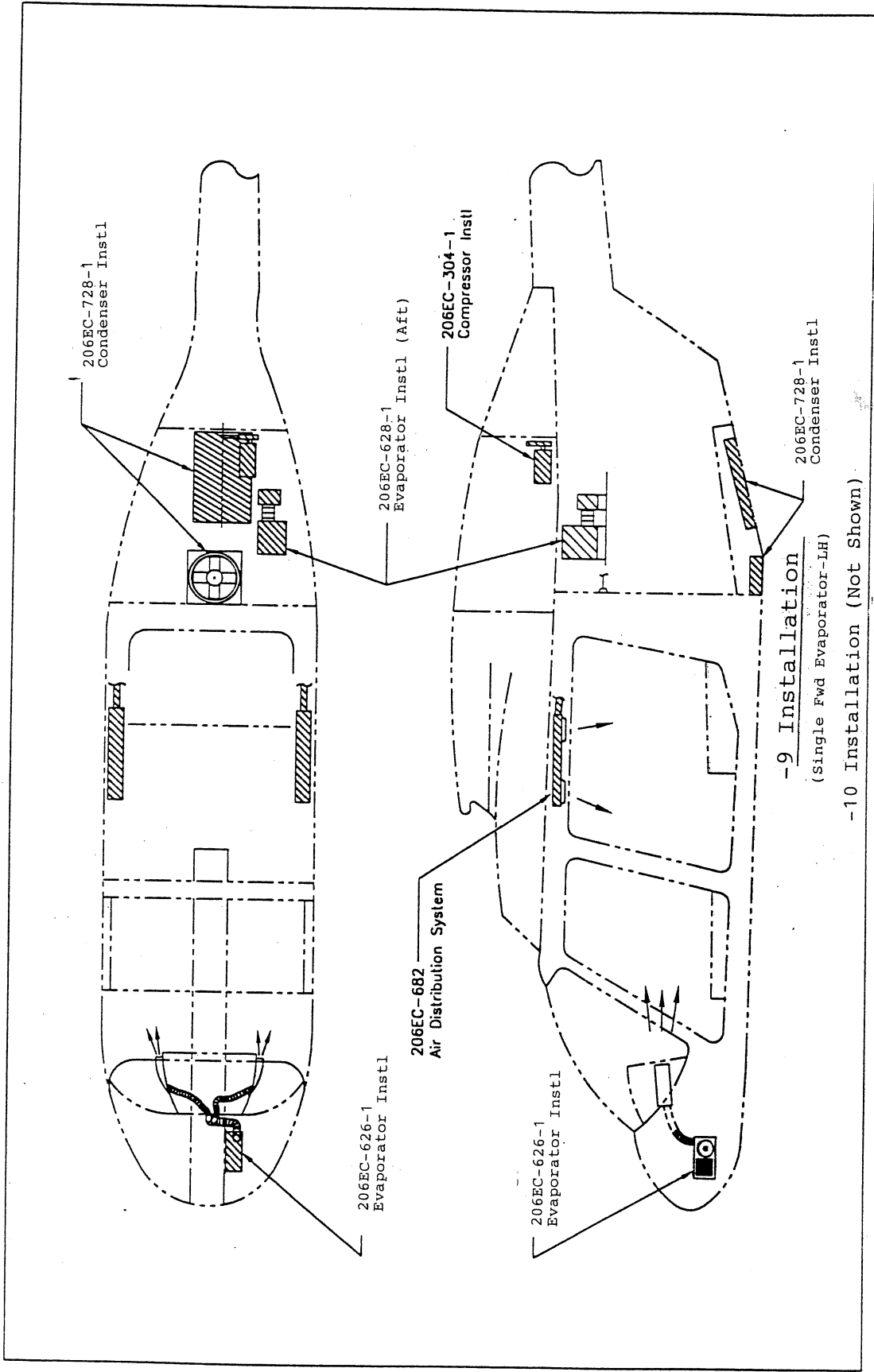

General Arrangement - Air Conditioner System with single Forward Evaporator

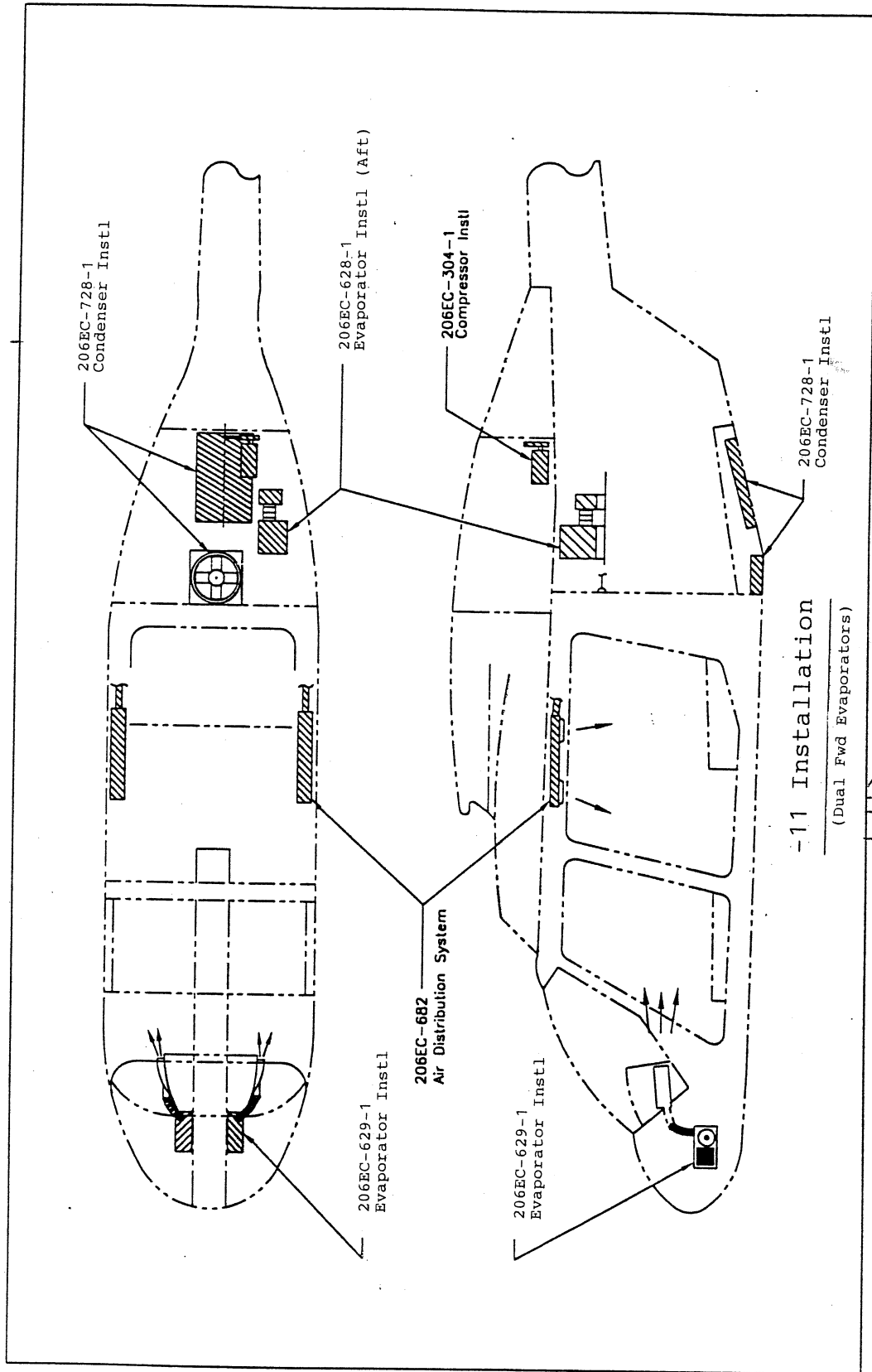

General Arrangement - Air Conditioning System with Dual Forward Evaporator

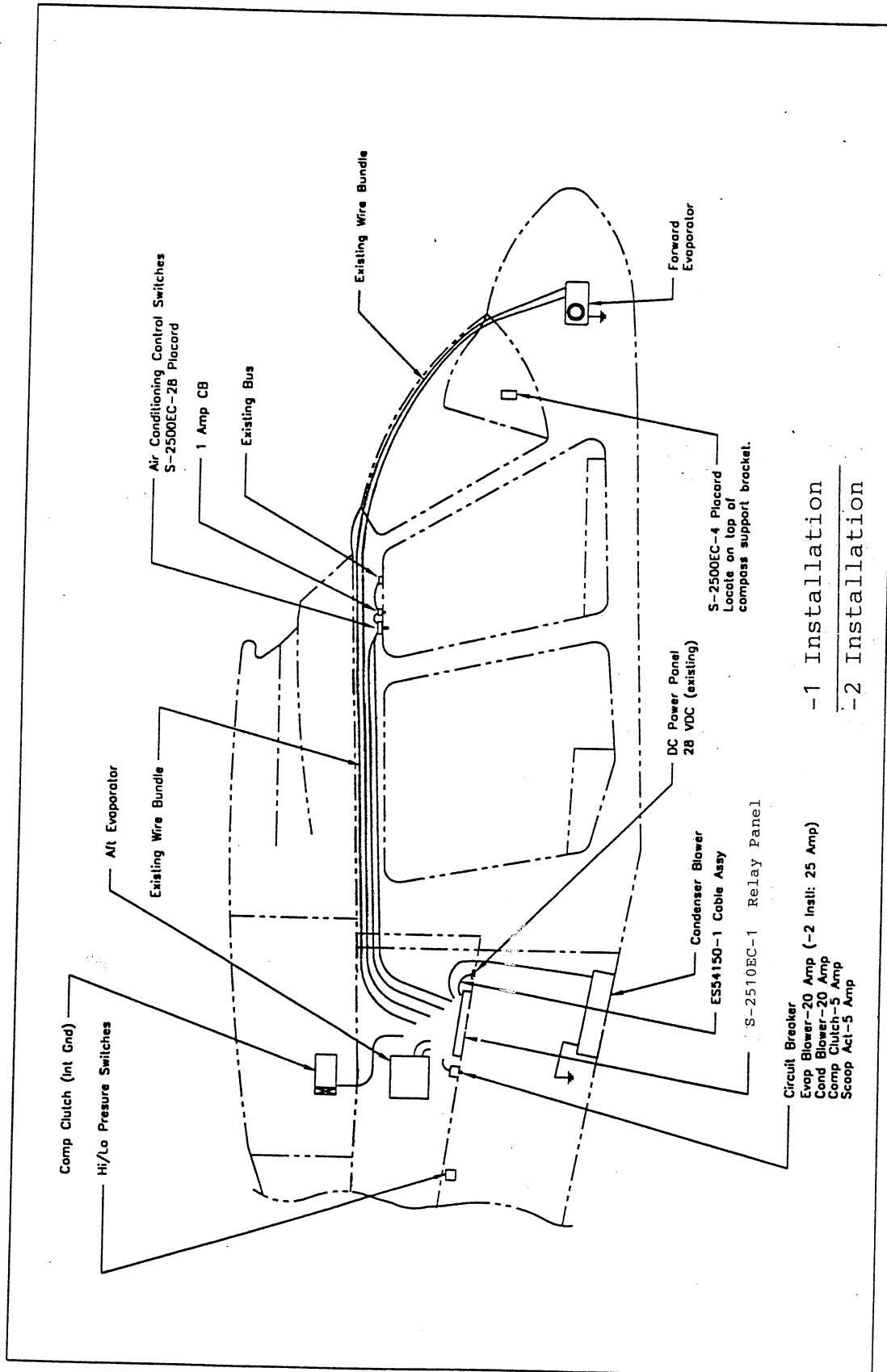

- 1 Installation
- 2 Installation

General Arrangement – Electrical Systems Components

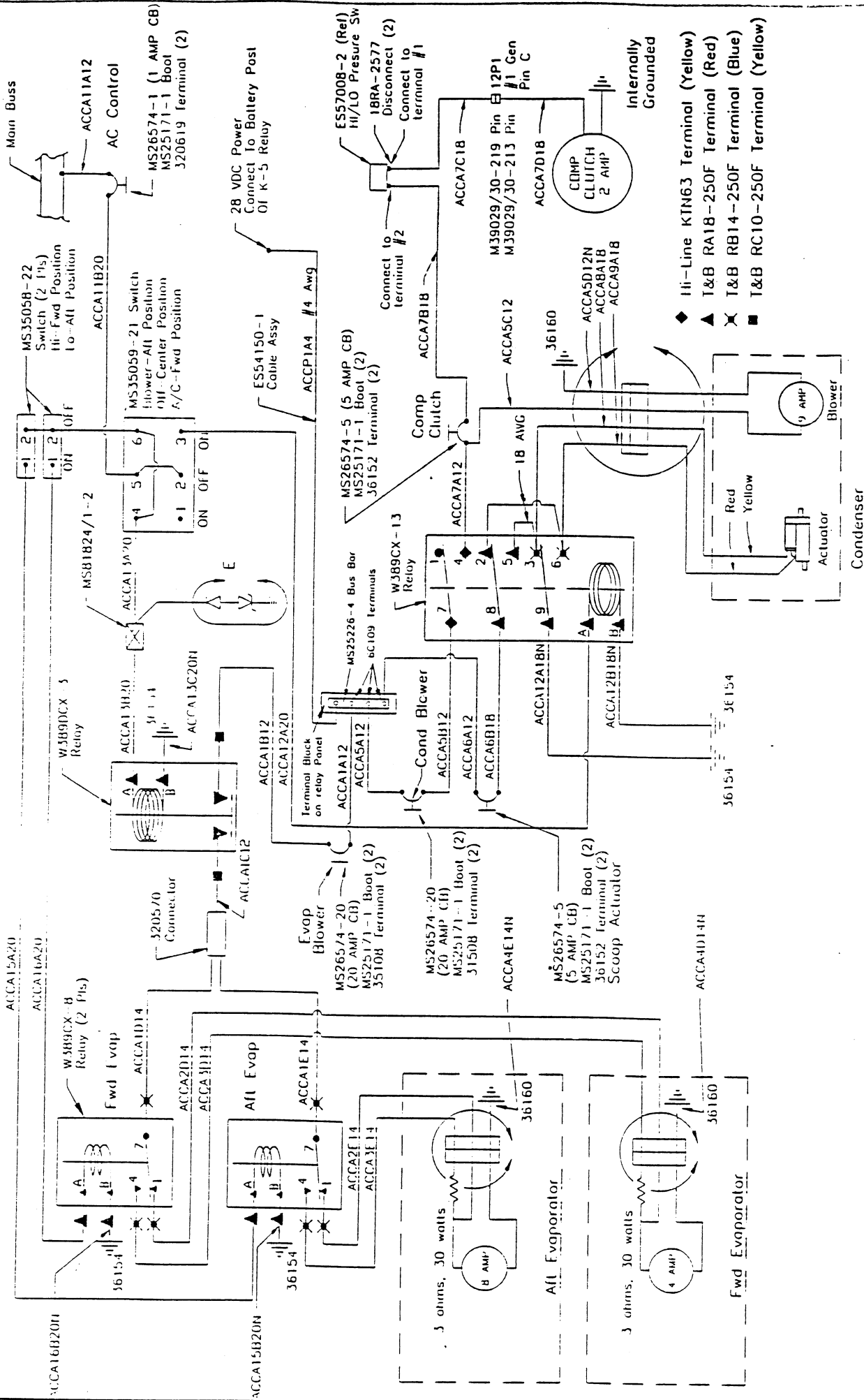

Electrical Schematic - Single Forward Evaporator

- ◆ Hi-Line KTN63 Terminal (Yellow)
- ▲ T&B RA18-250F Terminal (Red)
- ✕ T&B RB14-250F Terminal (Blue)
- T&B RC10-250F Terminal (Yellow)

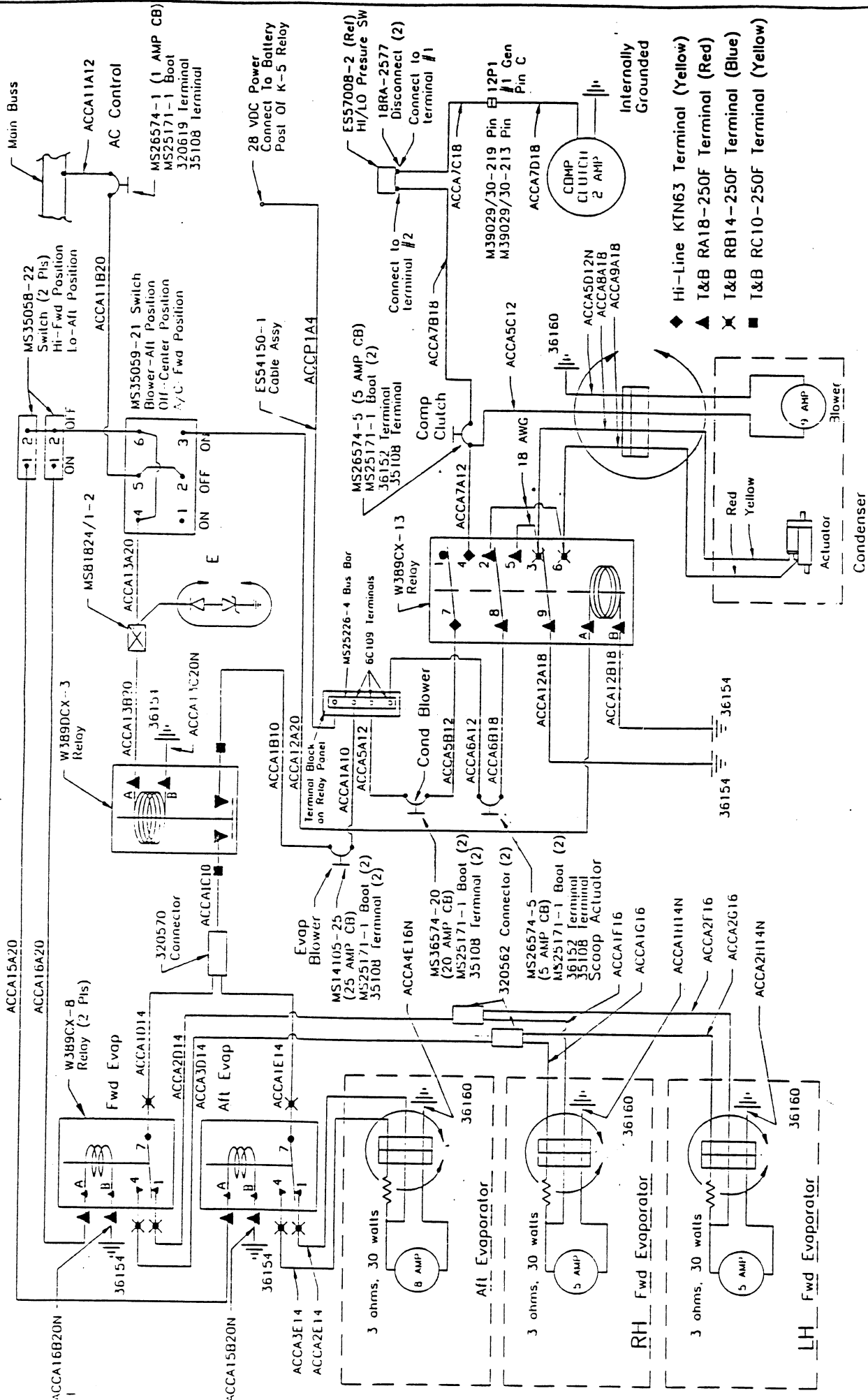

Electrical Schematic – Dual Forward Evaporator

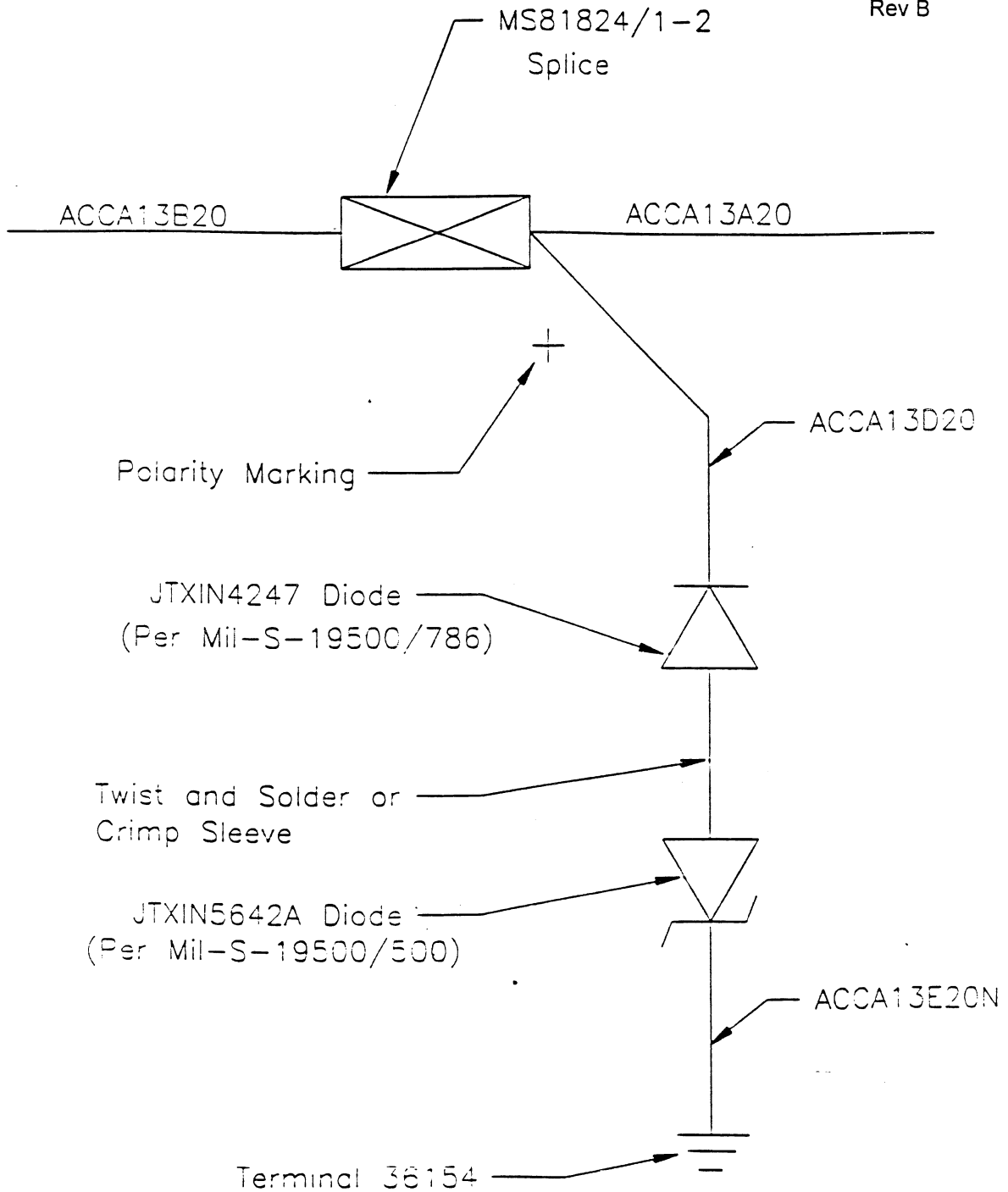

View E  
Transient Suppression Circuitry  
(Alternate: 30-214-1 Diode Assy)

Install washers with rounded edge side adjacent to disc assy where two washers are specified in contact with each other, the flat side of the washer shall be installed back to back.

\* Existing Hardware

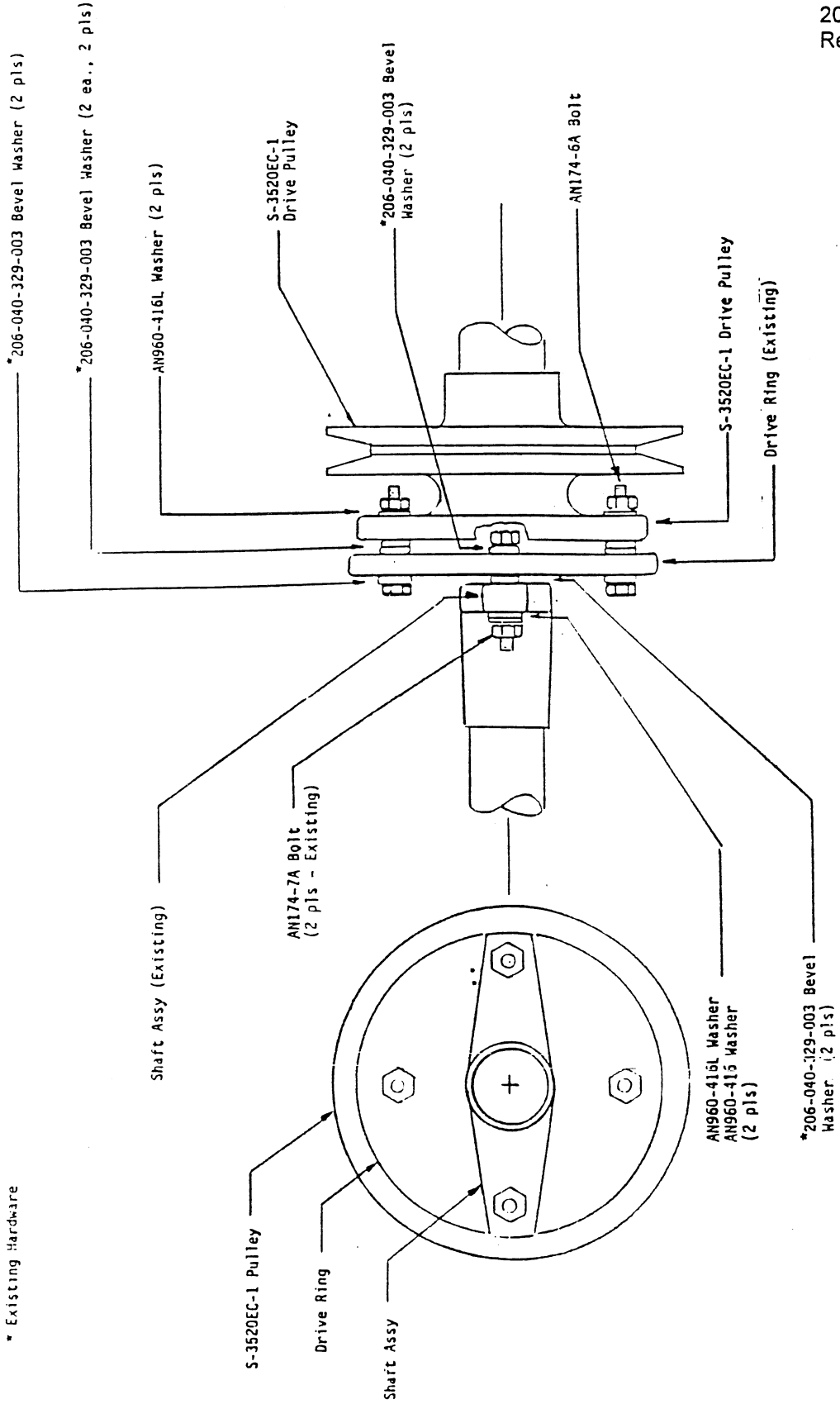

Drive Pulley Installation - 206 A/B



**Warranty & Parts Return Policy**

# WARRANTY

## **AIR COMM CORPORATION** **Cabin Heating & Air Conditioning Systems**

### Warranty Terms

Air Comm Corporation (hereafter referred to by ACC) warrants that products manufactured by ACC shall be free of defects in materials and workmanship for a period of one year from the date of installation and / or 1000 hours of flying time, which ever occurs first.

### Limitations and Exclusions

Installation, maintenance and operation of the product must be in accordance with the specifications and instructions provided by ACC. The warranty registration must be returned to ACC within ten days of the date of installation.

This warranty shall not apply to any product repaired or altered by parties other than ACC unless express prior authorization is granted; nor shall this warranty apply to any product subjected to misuse or accident unless proof is submitted to the satisfaction of ACC that such misuse or accident was not a cause for the claimed defect.

The sole responsibility and liability of ACC and your exclusive remedy under any claim arising out of, connected with, or resulting from, this sale or the performance of breach of any condition of warranty thereunder, or from the manufacture, delivery, or use of the product shall be the repair or replacement of defective parts. Labor costs shall not be covered under any circumstances.

In no event, whether as a result of a breach of contract, warranty, tort (including negligence) or otherwise, shall ACC be liable for any special, consequential, incidental or penal damages or expenses including but not limited to loss of profit, goodwill, or revenues, loss of use of the equipment or any associated equipment, damage to associated equipment, cost of capital, cost of substitute products, facilities or services, down time, or cost or claims of third parties for such damages or expenses.

THE FOREGOING WARRANTY IS EXCLUSIVE AND IN LIEU OF ALL OTHER WARRANTIES OR REMEDIES WHETHER WRITTEN, ORAL, IMPLIED OR STATUTORY. ANY AND ALL IMPLIED WARRANTIES OR MERCHANTABILITY, FITNESS FOR A PARTICULAR PURPOSE, COURSE OF DEALING OR USAGE OF TRADE ARE HEREBY EXPRESSLY DISCLAIMED AND EXCLUDED.

Acceptance of the product by you shall constitute your acknowledgment and acceptance of the terms, provisions, limitations and exclusions set forth herein. Such terms, provisions, limitations and exclusions shall not be modified, deleted or supplemented except by an express written acknowledgment of ACC.

WARRANTEE PERFORMANCE: All claims under this warranty shall be made to ACC. All returned parts must be shipped prepaid for evaluation. Full details of the symptoms of the malfunction should be included to assist in the evaluation. Warranty credit or replacement will be extended only after ACC has determined that all conditions of this warranty have been met.

Air Comm Corporation  
3300 Airport Road  
Boulder, CO. 80301  
Phone 303-440-4075  
Fax 303-440-6355

# Air Comm Corporation Malfunction Report

**Submitted To:**

Air Comm Corporation  
3300 Airport Road  
Boulder, CO. 80301  
Attn: Service Manager  
Phone No. 303-440-4075  
Fax No. 303-440-6355

Date Reported or Claim Filled \_\_\_\_\_/\_\_\_\_\_/\_\_\_\_\_  
Date Discrepancy Occurred \_\_\_\_\_/\_\_\_\_\_/\_\_\_\_\_

**Submitted By:** (Company Name, Address, Phone No.)

**Submitted For:** (Company Name, Address, Phone No.)

\_\_\_\_\_  
\_\_\_\_\_  
\_\_\_\_\_

\_\_\_\_\_  
\_\_\_\_\_  
\_\_\_\_\_

Phone Number \_\_\_\_\_

Phone Number \_\_\_\_\_

Fax Number \_\_\_\_\_

Fax Number \_\_\_\_\_

Person to contact \_\_\_\_\_

Person to contact \_\_\_\_\_

All warranty parts claims must be accompanied by the following information, failure to do so may delay the ability of ACC to determine the validity of the claim.

**Aircraft Data:** ( Please complete all sections )

Model No.	Registration No.	Serial No.	Delivery Date	Total Hrs. at Delivery	Hrs. at Occurrence

**Part Data:** ( Please complete all sections )

Quantity	Part Number	Part Name	Serial No. (if available)	Hrs. at Occurrence

Is this original equipment Yes                      No (if no, please complete these two blocks) ▶	Date Installed	Total A/C Hrs. when installed

Describe (in detail) of how the part failed, or reason for its return, (Please give any information that may be helpful in the evaluation of this part). \_\_\_\_\_

\_\_\_\_\_  
\_\_\_\_\_  
\_\_\_\_\_

<b>Warranty:</b>	
Approved	Disapproved

## Warranty Registration

**Aircraft Model** \_\_\_\_\_ **Serial #** \_\_\_\_\_

**Aircraft Registration Number** \_\_\_\_\_

**Installer's Name** \_\_\_\_\_

**Product #** \_\_\_\_\_

**Description** \_\_\_\_\_

**Deliver Date** \_\_\_\_\_

**Installation Date** \_\_\_\_\_

**Total Aircraft Time** \_\_\_\_\_

**Installers Name (Company)** \_\_\_\_\_

**Street** \_\_\_\_\_

**City** \_\_\_\_\_ **St** \_\_\_\_\_ **Zip** \_\_\_\_\_

**Owners Signature** \_\_\_\_\_

**Title (If Applicable)** \_\_\_\_\_

**Date** \_\_\_\_\_