

**AIR COMM CORPORATION**

1575 W. 124<sup>th</sup> Ave, Suite 210  
WESTMINSTER, CO. 80234  
PHONE: 303-440-4075 FAX: 303-440-6355  
[INFO@AIRCOMMCORP.COM](mailto:INFO@AIRCOMMCORP.COM)

**INSTRUCTIONS FOR CONTINUED AIRWORTHINESS  
AIRBUS AS350  
AIR CONDITIONING SYSTEM**



**THIS HANDBOOK INCLUDES THE MAINTENANCE INFORMATION  
REQUIRED TO BE AVAILABLE BY FAR PART 27**

**Revision 10**

**January 14, 2021**

**RESTRICTED DISCLOSURE NOTICE**

THIS PUBLICATION IS THE PROPRIETARY INTELLECTUAL PROPERTY OF AIR COMM CORPORATION AND IS DELIVERED TO THE RECIPIENT WITH THE EXPRESS CONDITION THAT IT AND THE INFORMATION CONTAINED HEREIN ARE NOT TO BE USED, DISCLOSED OR REPRODUCED IN PART OR IN WHOLE, FOR ANY PURPOSE WITHOUT THE EXPRESS WRITTEN CONSENT OF AIR COMM CORPORATION. NO RIGHT IS GRANTED TO THE RECIPIENT TO DISCLOSE OR SO USE ANY INFORMATION CONTAINED IN THIS DOCUMENT OUTSIDE THE PURPOSE FOR WHICH IT WAS DELIVERED. THESE RESTRICTIONS DO NOT OPERATE TO NULLIFY OR LIMIT ANY RIGHTS GRANTED BY CONTRACT.



## AIR CONDITIONER SERVICE MANUAL AS350-200M-1

7	06/20/2019	Pg 51: Updated Figure 8-1 Pg 52: Updated Figure 8-2	<p>Prepared By:</p> <p><u>C Posvic</u>                      <u>06/20/2019</u> Date</p> <hr/> <p>ACC Approval:</p> <p><u>M. Krauss</u>                      <u>07/02/2019</u> Signature                      Date</p> <hr/> <p>FAA Acceptance</p> <p>N/A – Meets Minor Change Agreement MR-100-134</p> <p>_____ <u>06/20/2019</u> Signature                      Date</p>
8	12/09/2019	Pg 22: Updated Figure 4-14 Pg 35: Added AS350-8424-1 to suggested spares list Pg 48: Added EMI filter replacement instructions Pg 51: Updated Figure 8-1 Reference ECO 19-490	<p>Prepared By:</p> <p><u>R. Dodrill</u>                      <u>12/09/2019</u> Date</p> <hr/> <p>ACC Approval:</p> <p><u>M.Krauss</u>                      <u>12-13-19</u> Signature                      Date</p> <hr/> <p>FAA Acceptance</p> <p>N/A – Meets Minor Change Agreement MR-100-134</p> <p>_____ <u>12/09/2019</u> Signature                      Date</p>

# AIR CONDITIONER SERVICE MANUAL AS350-200M-1

9	02/21/2020	Pg 52: Updated Figure 8-2 Reference ECO 20-041	Prepared By:  <u>R. Longcrier</u> <u>02/21/2020</u> <div style="text-align: right;">Date</div>
			ACC Approval:  <u>M. Krauss</u> <u>3-5-2020</u> Signature      Date
			FAA Acceptance  N/A – Meets Minor Change Agreement MR-100-134  <div style="text-align: right;"><u>02/21/2020</u></div> Signature      Date
10	01/14/2021	Added ES73151-11 to the following locations: Pg 10: Component Overhaul/Replacement Schedule; Condenser Blower Motor Part Number Pg 19: Figure 4-11 Ref ECO 21-017	Prepared By:  <u>R. Longcrier</u> <u>01/14/2021</u> <div style="text-align: right;">Date</div>
			ACC Approval:  <u>M. Krauss</u> <u>1-14-21</u> Signature      Date
			FAA Acceptance  N/A – Meets Minor Change Agreement MR-100-134  <div style="text-align: right;"><u>1/14/21</u></div> Signature      Date

THIS PAGE INTENTIONALLY LEFT BLANK

**LIST OF EFFECTIVE PAGES**

All pages contained herein are at latest revision shown in Record of Revisions.

List of Effective Pages

1 – 53

THIS PAGE INTENTIONALLY LEFT BLANK



TABLE OF CONTENTS

CHAPTER 1 ..... 1  
INTRODUCTION ..... 1  
1. Scope..... 1  
2. Purpose ..... 1  
3. Arrangement ..... 1  
4. Applicability ..... 1  
5. Definitions ..... 1  
6. Abbreviations ..... 2  
7. Precautions ..... 2  
8. Units of Measure ..... 2  
9. Information Essential to Continued Airworthiness ..... 2  
10. Reference Documents ..... 2  
11. Distribution ..... 3  
12. Changes to Instructions for Continued Airworthiness ..... 3  
13. Air Conditioner Features ..... 3  
14. Description of Vapor Cycle Air Conditioner and Installation ..... 5  
CHAPTER 2 ..... 7  
AIRWORTHINESS LIMITATION SECTION ..... 7  
1. Airworthiness Limitations ..... 7  
CHAPTER 3 ..... 9  
INSPECTIONS AND OVERHAUL ..... 9  
1. Inspection Requirements ..... 9  
2. Component Overhaul / Replacement Schedule ..... 10  
CHAPTER 4 ..... 11  
LOCATION AND ACCESS ..... 11  
1. Location of Air Conditioner Components ..... 11  
CHAPTER 5 ..... 28  
PLACARDS AND MARKINGS ..... 28  
1. Placard and Marking Information ..... 28  
CHAPTER 6 ..... 30  
SERVICING ..... 30  
1. Safety Precautions ..... 30

## AIR CONDITIONER SERVICE MANUAL AS350-200M-1

2.	Servicing Information .....	30
3.	Lubrication Information .....	32
4.	System Leak Check .....	33
5.	Suggested Equipment for Servicing.....	34
6.	Consumable Materials .....	34
7.	Suggested Spares List.....	35
CHAPTER 7 .....		36
STANDARD PRACTICES AND INFORMATION .....		36
1.	General Information .....	36
2.	Fitting Torque Procedures and Values.....	36
3.	Removal and Replacement of Forward Evaporator Assembly.....	37
4.	Removal and Replacement of Forward Evaporator Blower Motor Assembly	38
5.	Removal and Replacement of Aft Evaporator Assembly .....	39
6.	Removal and Replacement of Aft Evaporator Blower Motor .....	39
7.	Removal and Replacement of Condenser Assembly.....	40
8.	Removal and Replacement of Condenser Blower Assembly.....	41
9.	Removal and Replacement of Condenser Assembly.....	41
10.	Removal and Replacement of Condenser Vane Axial Blower .....	42
11.	Removal and Replacement of Compressor Drive Belt.....	42
12.	Adjustment of Compressor Drive Belt.....	44
13.	Removal and Replacement of Compressor Assembly.....	45
14.	Removal and Replacement of Receiver Drier Bottle.....	46
15.	Removal and Replacement of Bypass Valve .....	47
16.	Removal and Replacement of Binary Switch .....	47
CHAPTER 8 .....		49
TROUBLESHOOTING.....		49
1.	System Troubleshooting .....	49
	Figure 8-1 – Electrical Schematic, Side Baggage Mounted Condenser (Tail Boom Condenser Option identical except for additional condenser blower.).....	51
	Figure 8-2 – Electrical Schematic, Relay Panel .....	52
APPENDIX A.....		53
WEIGHT AND BALANCE INFORMATION .....		53

## CHAPTER 1 INTRODUCTION

### 1. Scope

The scope of this manual encompasses scheduled and unscheduled maintenance procedures for continued airworthiness of Air Comm Corporation air conditioning system installed in the Airbus AS350 series helicopter.

### 2. Purpose

The purpose of this manual is to provide aircraft field mechanic necessary information to maintain the air conditioning system.

### 3. Arrangement

This manual is arranged by chapters which are broken down into paragraphs and subparagraphs. All chapters and paragraphs are listed in the front of this manual in the Table of Contents, and are further identified by their individual page number.

### 4. Applicability

This manual is applicable to Airbus Helicopter models AS350 which are equipped with the Air Comm Corporation kit part number AS350-200, AS350-202 or AS350-204 air conditioner systems.

### 5. Definitions

The following terms are provided to give a ready reference to the meaning of some words contained within this manual. These definitions may differ from those given by a standard dictionary.

**Ambient air temperature:** Temperature of the air surrounding a person or object.

**Charging station:** An air conditioning system service unit which is capable of evacuating and charging an air conditioner.

**Condensation:** The process of changing a vapor into a liquid.

**Desiccant:** Material used in a receiver/drier bottle, designed to absorb moisture from refrigerant.

**Heat load:** The amount of heat which the air conditioner is required to remove from the aircraft cabin.

**Inches of mercury:** A measurement of pressure, normally used for pressures below atmospheric, one inch of mercury is equal to approximately one half pound per square inch.

**Pressure, ambient:** The pressure of the air surrounding a body, normally measured in pounds per square inch, or PSIG.

**Refrigerant:** A fluid which is used in an air conditioning system to absorb heat from the cabin and carry it outside the helicopter where it can be transferred to the outside air.

**Relative humidity:** The ratio of the amount of water vapor in the air to the amount of water vapor required to saturate the air at the existing temperature.

**Thermostat:** An air conditioning control which senses the temperature of the evaporator coil and causes the system to cycle or by-pass to maintain the proper temperature of cooling air.

## **6. Abbreviations**

**gm:** Gram

**kg:** Kilograms

**inHg:** Inches of Mercury

**In-lbs:** Inch pounds

**Kg/cm:** Kilograms Per Centimeter

**lbs:** Pounds

**ml:** Milliliters

**mm:** Millimeters

**Nm:** Newton-meters

**oz:** Ounces

**Psig:** Pounds Per Square Inch (gauge)

## **7. Precautions**

The following precautions are found throughout this manual, and will vary depending on the seriousness of the Hazard or Condition:

**WARNING:** May be a maintenance procedure, practice, condition, etc., which could result in personal injury or loss of life.

**CAUTION:** May be a maintenance procedure, practice, condition, etc., which could result in damage or destruction of equipment.

**NOTE:** May be a maintenance procedure, practice, condition, etc., or a statement which needs to be highlighted.

## **8. Units of Measure**

All measurements contained within this manual are given in United States standard measurement, followed by metric conversion in parentheses.

## **9. Information Essential to Continued Airworthiness**

This manual provides information which is required for operation and maintenance of the Air Comm air conditioning system installed in the Airbus model AS350 series helicopter. After completion of the air conditioner installation this document must be placed with the appropriate existing aircraft documents.

## **10. Reference Documents**

The approval basis of the system covered by this ICA is Supplemental Type Certificate SR00643DE.

**11. Distribution**

This document is to be placed with the aircraft maintenance records at the time of system installation.

Changes will be made to this document in response to safety-of-flight or non-safety-of-flight issues. Any changes will result in a revision to this document. Revisions shall be noted in the Record of Revisions and on the List of Revisions of this manual.

In addition to the revision of the manual, those changes categorized as safety-of-flight shall have a Service Bulletin issued to the operator providing the necessary information to comply with or to correct the safety-of-flight issue.

Replacement or revised copies of this manual can be obtained by contacting:

Air Comm Corporation Service Department  
1575 124<sup>th</sup> Avenue, Suite 210  
Westminster, CO 80234  
Phone No. 303-440-4075 Fax No. 303-440-6355  
Email: info@aircommcorp.com

**12. Changes to Instructions for Continued Airworthiness**

Changes made to a line or paragraph of this document will be indicated by a vertical bar in the right hand margin. A complete page change will be indicated by a vertical bar next to the page number.

(Example: Any change will appear with a vertical bar next to that change).

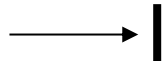

**13. Air Conditioner Features**

The AS350 air conditioner features one forward mounted evaporator assembly (cockpit), one aft mounted evaporator assembly (behind main cabin), one condenser assembly, and a compressor driven by the main rotor input shaft just aft of the aft main transmission, aircraft left. These components and associated plumbing combine to provide conditioned air through the existing air distribution system when the engines are operating during both ground and flight operations.

This system can be operated in either the Air Condition (A/C), or Fan mode. In the A/C mode, conditioned air is provided by the forward and aft evaporator assemblies to the cockpit and main cabin areas respectively. In Fan mode, the evaporator blowers are used to circulate cabin air, while the compressor clutch remains disengaged. When using the cabin heater it is acceptable to operate the air conditioner if desired, to defog the cabin windows.

The air conditioning system is connected electrically to the aircraft's DC Power Panel 28 VDC Bus. The control panel for the air conditioner system is located on the cockpit overhead panel or instrument panel. The control panel consists of an A/C & Fan switch, two switches for the control of cockpit and cabin evaporator blower speeds, a temperature control rheostat knob and a panel light dimmer rheostat knob. Temperature control is achieved by means of a refrigerant bypass valve, thus eliminating compressor cycling. The fan motors feature dual fan speed. This feature can be used in both the A/C or fan modes.

## AIR CONDITIONER SERVICE MANUAL AS350-200M-1

A "COMP ON" green or blue annunciator, located on the instrument panel, provides a visual status of compressor operation. For aircraft equipped with a VIVISUN lighted pushbutton switch, compressor engagement is displayed on the switch as a blue "COMP ON" annunciation.

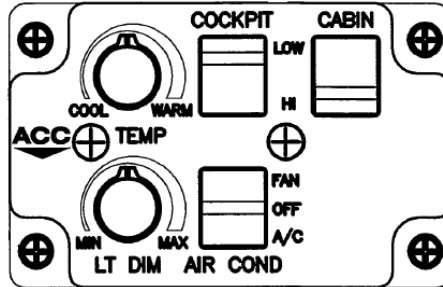

**Figure 1-1 – Air Conditioning System Control Panel**

The compressor is mounted on the surface of the main gearbox coupling case, in the aft aircraft center portion of the transmission compartment. It is driven by a flat or Poly V-Belt and a pulley which is mounted to the main rotor input shaft. Access to the compressor is provided by the transmission compartment access doors.

The condenser assembly for the -200 & -202 systems is mounted in the upper RH baggage compartment and features a blower assembly and a separate heat exchanger to reject system heat overboard. Airflow through the condenser heat exchanger is provided by a 28 volt DC high performance blower. For the optional -204 system, the condenser is mounted in the forward tail boom and features dual blowers.

The forward evaporator is mounted on the right side of the lower console forward of the anti-torque pedals. Conditioned air is delivered to the crew by means of air ducts, mounted to the sides of the instrument panel console.

The aft evaporator assembly is mounted on the transmission deck, RH side and is enclosed by the transmission cowling. Cabin return air is ducted to the evaporator through a cutout in the aft cabin bulkhead. Conditioned air is pumped to the existing headliner ducting in the cabin top.

The aft evaporator assembly is equipped with a freeze switch. The freeze switch probe is located in the core of the evaporator heat exchanger. This switch prevents coil freeze-up by limiting the minimum coil temperature to 32° F (0° C).

The system is also equipped with a binary pressure switch. This switch is designed to protect the system against over-pressure situations, or under-pressure in the event of refrigerant loss from the system. The switch also prevents the system from operating in low ambient temperatures below 50° F (10° C).

The switch operating pressures are:

<u>Low Pressure Function:</u>	<u>High Pressure Function:</u>
Open at 28 psig (1.97 kg/cm)	Open at 384 psig (27.0 kg/cm)
Close at 29 psig (2.04 kg/cm)	Close at 298 psig (21.0 kg/cm)

As a backup measure to protect the system from an over-pressure situation a pressure relief valve is also incorporated into the flow circuit. The relief valve will open between 550 and 610 psi and will re-close once pressures are relieved below those pressures.

### **14. Description of Vapor Cycle Air Conditioner and Installation**

This section contains a general overview of a vapor-cycle air conditioning system and how it functions. This type of system operates in a closed loop, in which the refrigerant absorbs heat from the cabin and rejects it into the outside air. The refrigerant then returns to the cabin to repeat the cycle. The operation of the system is described below (See Figure 1-2).

The compressor receives low pressure heat laden refrigerant vapor from the evaporators. The compressor pressurizes the refrigerant depending on system demand. This increases the temperature of the refrigerant. At this temperature and pressure the refrigerant is above its boiling point. The compressor discharges superheated refrigerant vapor to the condenser.

The refrigerant flows into the condenser. The condenser has numerous cooling fins in which the vapor is pumped. In the condenser the high pressure vapor condenses into a high pressure liquid by reducing the temperature of the refrigerant. This is achieved by forcing air over the surface of the condenser enabling heat to transfer from the refrigerant to the outside air thus reducing its temperature. Only refrigerant in the form of a high pressure liquid leaves the condenser outlet.

The high pressure liquid refrigerant flows into the receiver-drier which stores, dries and filters the liquid refrigerant.

The liquid refrigerant then flows from the receiver-drier to the expansion valves. The expansion valves changes the refrigerant into low pressure, low temperature liquid/vapor by lowering the pressure using a variable orifice. The orifice has high pressure on one side (from the receiver-drier) and low pressure on the other (evaporator and compressor) and allows a small quantity of refrigerant to flow through it. The sudden drop in pressure and temperature causes some of the refrigerant to vaporize. The low pressure low temperature liquid/vapor then flows to the evaporator where the heat is transferred from its surface to the refrigerant through vaporization. The heat comes from inside the cabin and is blown over the evaporator's surface. Once the refrigerant has completely vaporized and reached its saturation point it should still be able to carry more heat. The refrigerant continues to flow through the remainder of the evaporator coils absorbing more heat and becoming slightly superheated.

The low pressure low temperature slightly superheated vapor refrigerant flows to the compressor and the cycle repeats itself.

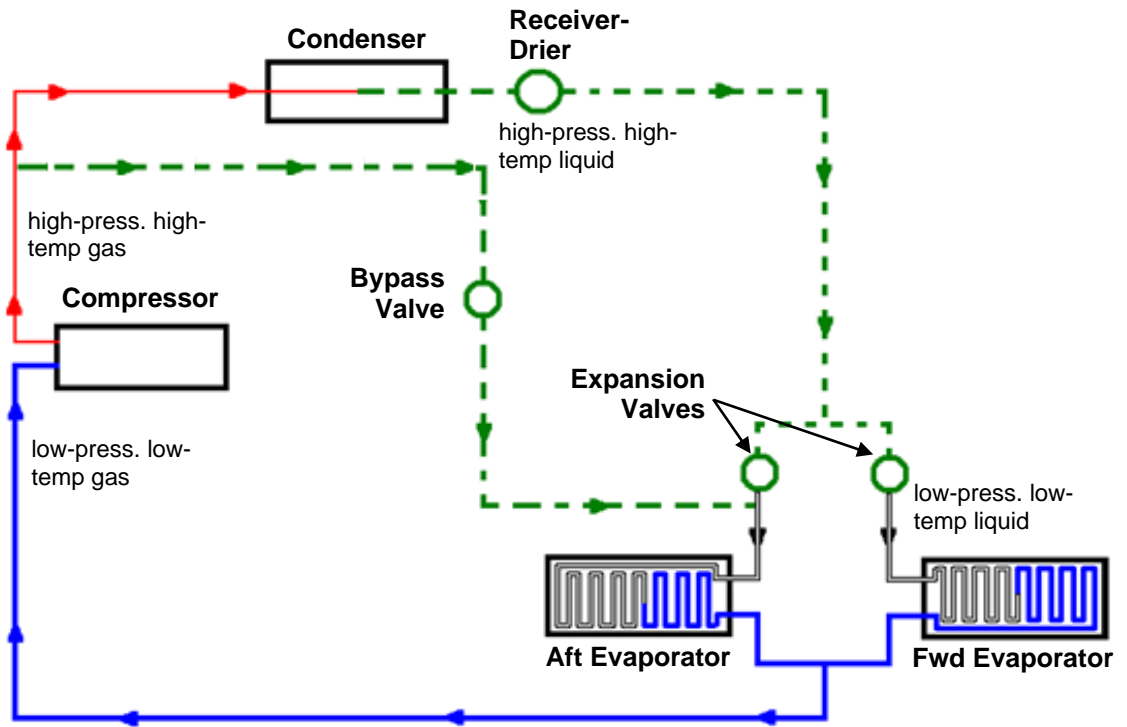

**Figure 1-2 – Refrigeration Cycle Illustration**

(NOTE: This illustration is provided as a reference only and may not match actual installation)



**CHAPTER 2**  
**AIRWORTHINESS LIMITATION SECTION**

**1. Airworthiness Limitations**

The Airworthiness limitations section is FAA approved and specifies inspections and other maintenance required under Sections 43.16 and 91.403 of Federal Aviation Regulations unless an alternative program has been FAA approved.

“No airworthiness limitations are associated with this type design change.”

FAA approval:

---

ACO Representative

Date

THIS PAGE INTENTIONALLY LEFT BLANK

**CHAPTER 3  
INSPECTIONS AND OVERHAUL**

**1. Inspection Requirements**

**PERIODIC INSPECTIONS**  
(Hours are aircraft time)

Item	Annual	Every 25 Hours of Operation	Every 100 Hours of Operation	Special Inspection Information
Evaporator Blower Hi/Lo Operation	X		X	Check for operation
Condenser Blower(s)	X		X	Check for operation
Forward & Aft Evaporator Blower Motor	X		X	Check for operation in Hi and Lo settings
Compressor Drive Belt	X	X	X	Check belt tension, and for signs of excessive wear (example: glazing, cracks, and exposed fibers)
Air Conditioner Placards & Markings (see chapter 5)	X		X	Check for security and legibility
Air Conditioner Compressor Assembly	X	X	X	Check for operation, security of attaching hardware, and signs of oil or refrigerant leaks. Inspect compressor pulley assembly for minimum 0.3" (7.62 mm) clearance between pulley and transmission support tube
Air Conditioner Compressor Mount	X		X	Check for cracks and security of attaching hardware
Plumbing and Fittings	X		X	Check for security and signs of oil or refrigerant leaks
Air Conditioner Compressor drive pulley (mounted to main rotor input shaft)	X		X	Check for security of attaching hardware
Blower Electrical connectors	X			Visually inspect for signs of overheating. See sec. 2.0 below for details.

**2. Inspection Of Blower Electrical Connectors (annual requirement)**

a) Locate the Molex electrical connectors that power the aft evaporator and condenser blowers. See figures 4-1,2 and 4-9 thru 13. The connectors are at the interface between the blower harness and the aircraft harness and identified by their white plastic housing. Note that the evaporator blowers have an additional connector to inspect located several inches away from the harness connector.

NOTE: Aft evaporators supplied in late 2014 and newer use a gray plastic Deutsch connector and are not part of this inspection requirement.

## AIR CONDITIONER SERVICE MANUAL AS350-200M-1

b) De-mate each connector and inspect both mates for signs of overheating (discoloration or plastic deformation). If any signs of overheating of the housing are present the system must be rendered inoperative and the connector housing and contacts replaced before further operation. Contact ACC service dept. for replacement parts if necessary.

c) Installation & replacement of the wire harness electrical connectors for the evaporator and condenser blowers.

To avoid potentially serious overheating issues the Molex style connectors (identified by their white plastic housing) installed on the aircraft harness for connecting to the evaporator and condenser blowers must be installed per ACC procedure PPP23 and only using the appropriate terminal crimp tool. This document is available on the ACC website [www.aircommcorp.com/customer-support/service-manuals/](http://www.aircommcorp.com/customer-support/service-manuals/).

### **3. Component Overhaul / Replacement Schedule**

Description	Part Number	Overhaul / Replacement Hours
Forward Evaporator Blower Motor	ES61064-1	The blower manufacturer recommends TBO at 1000 hrs. At the discretion of the operator, it is acceptable to operate the blower until failure. A blower failure will result in a reduction in cooling, but no safety-of-flight issues are involved.
Aft Evaporator Blower Motor	ES61142-1	Same as above
Condenser Motor/Fan Assembly	ES73131-1 or ES73151-11 (side mount) S-7095EC-1 or -2 (tail boom)	Same as above

**CHAPTER 4  
LOCATION AND ACCESS**

**1. Location of Air Conditioner Components**

<b>Nomenclature</b>	<b>Description of Location</b>
Air Conditioner Circuit Breaker & Relay Panel	Forward bulkhead of right side baggage compartment
Air Conditioner Control Panel	Overhead panel or Instrument Panel
Forward (Cockpit) Evaporator and Blower	RH side center console below instrument panel in chin bubble area – blower is integral to forward evaporator
Aft (Main Cabin) Evaporator and Blower	Transmission deck just forward of transmission, right side
Condenser Assembly and Blower Assembly	RH baggage compartment (200 &202 Systems) Forward Tail Boom (Optional Configuration, 204 System)
Compressor	Aft LH section of transmission compartment
Refrigerant Plumbing	Routes from compressor, to area below baggage compartment, and forward to nose area (As refrigerant plumbing connects compressor, condenser, and evaporators, it may be necessary to access these components through several panels and cabin headliner)
Hi & Lo Service Ports	Adjacent to Aft Evaporator
Receiver Drier Bottle	Adjacent to condenser assembly in RH baggage compartment (200 &202 Systems), below right baggage compartment (204 Systems)
Bypass Valve	Aft cabin bulkhead in forward fuel bay
Binary Switch	Adjacent to Aft Evaporator

# AIR CONDITIONER SERVICE MANUAL AS350-200M-1

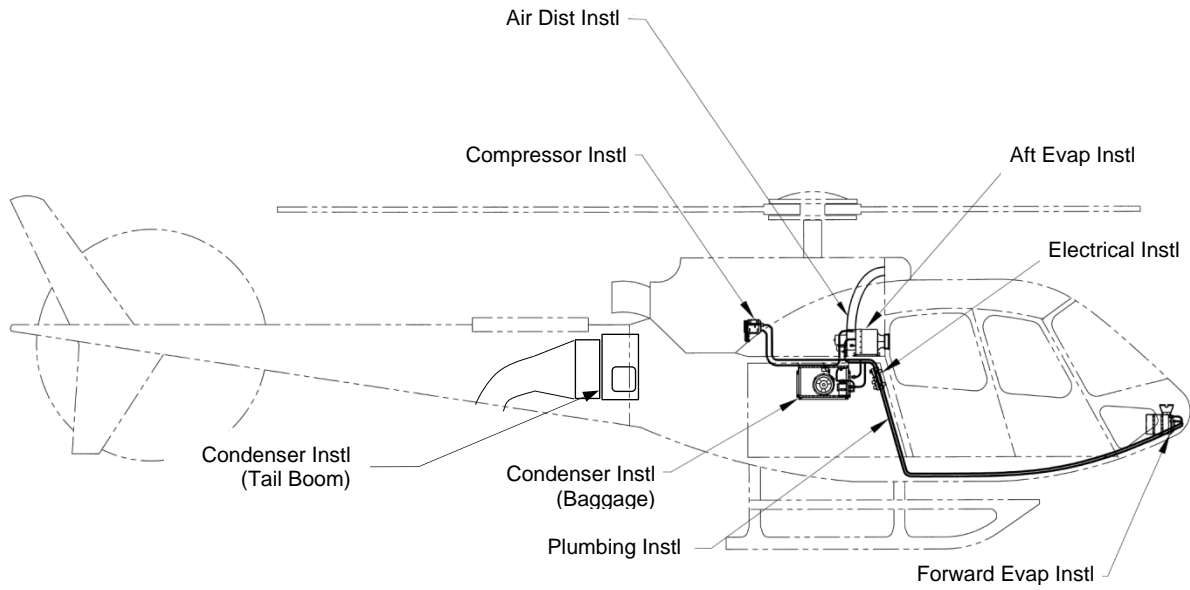

## SIDE VIEW

Figure 4-1 – Layout of AS350 Air Conditioning System

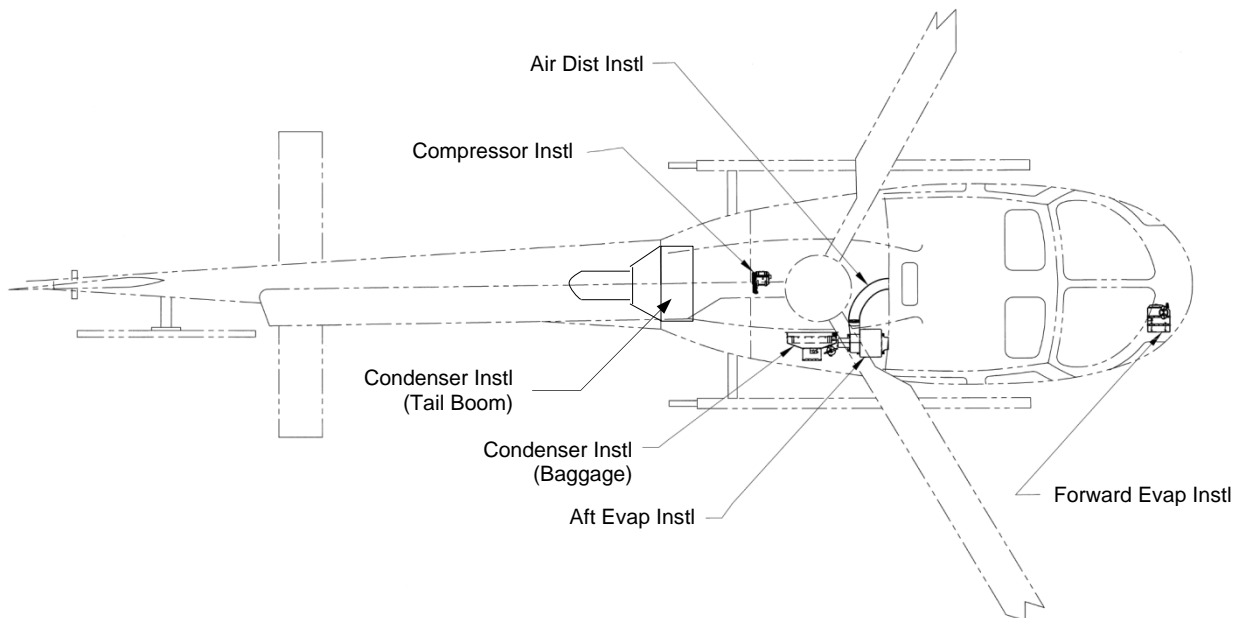

## TOP VIEW

Figure 4-2 – Layout of AS350 Air Conditioning System

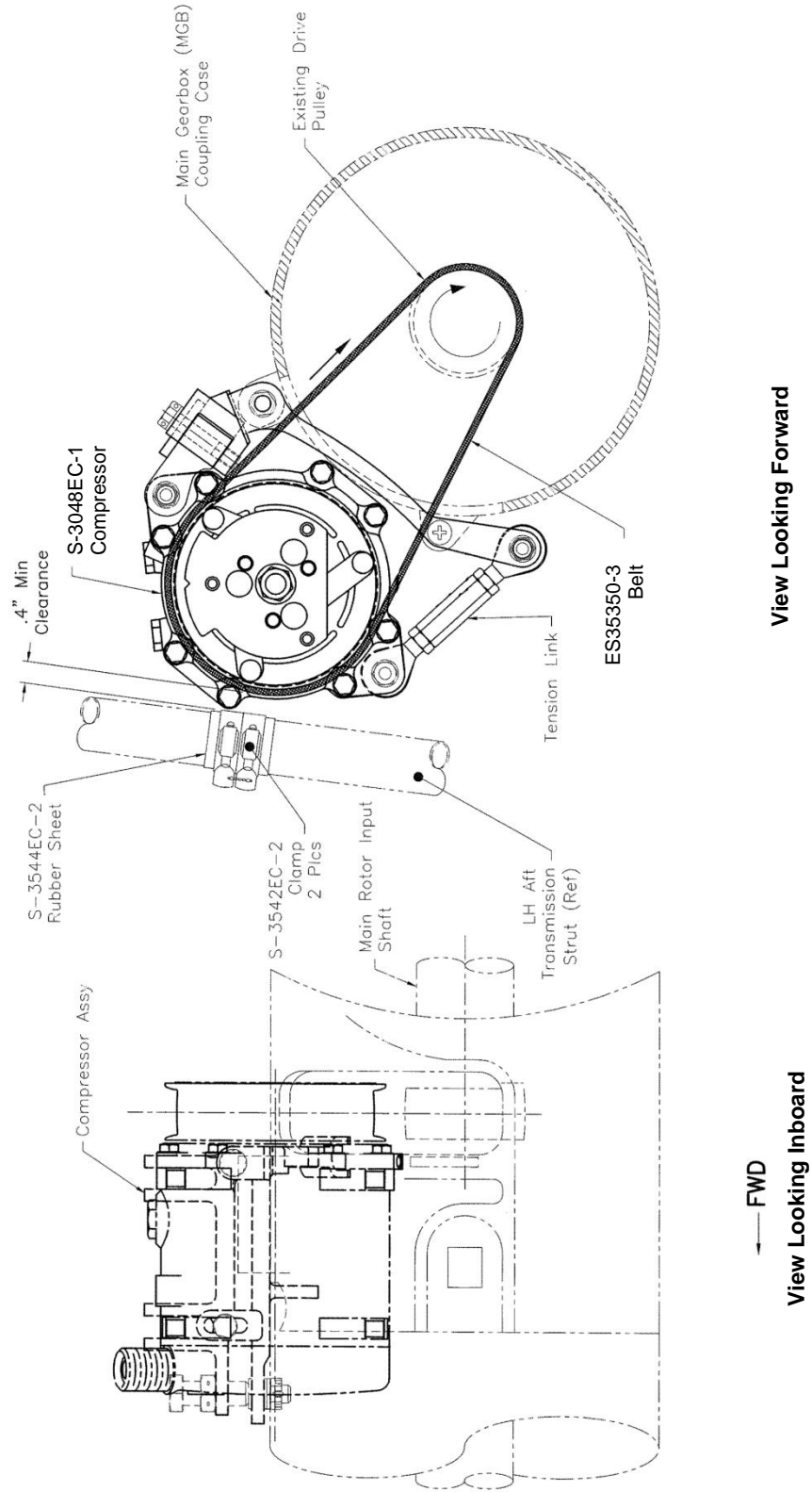

Figure 4-3 – Compressor Installation  
Flat Belt Configuration

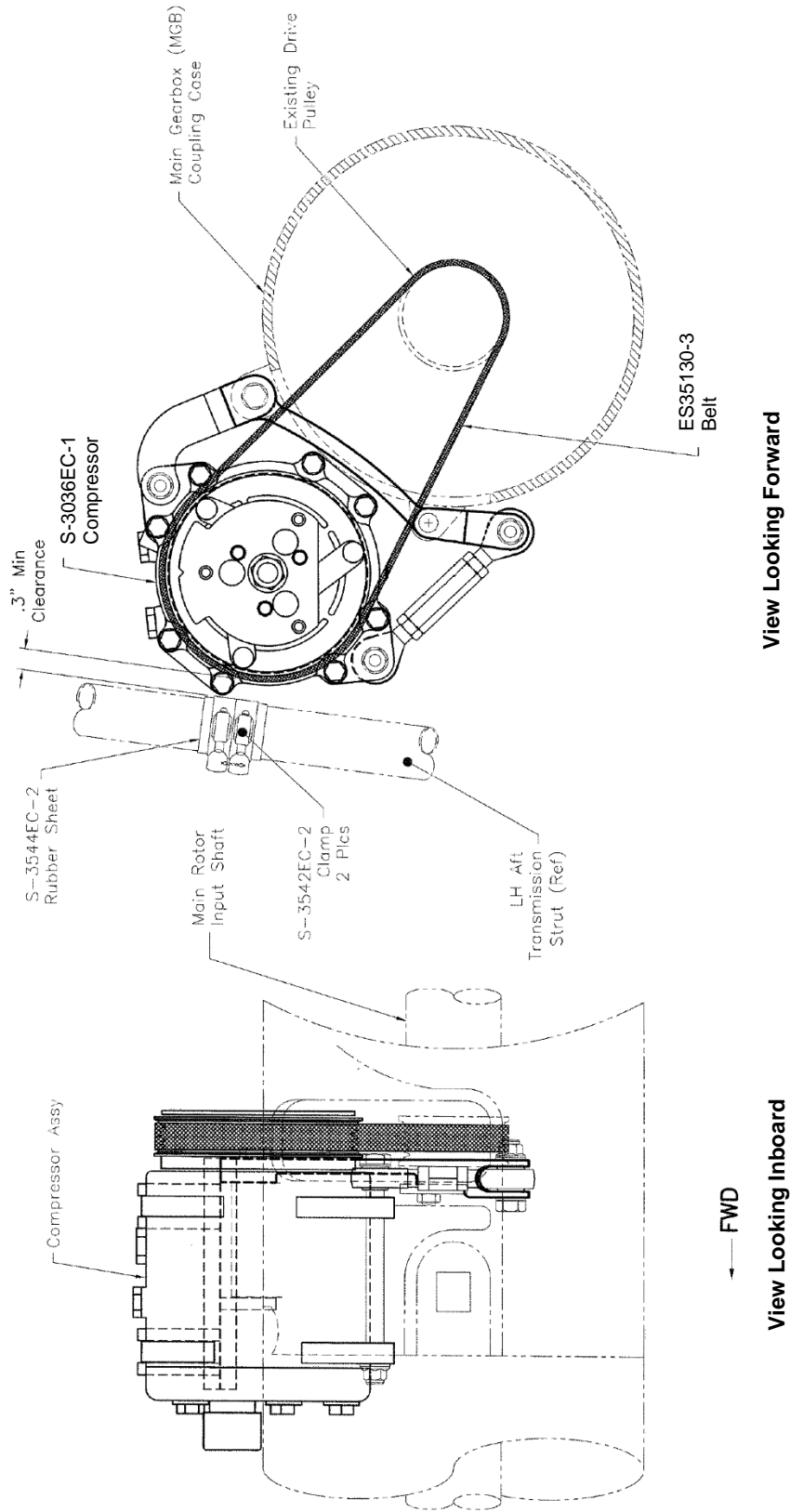
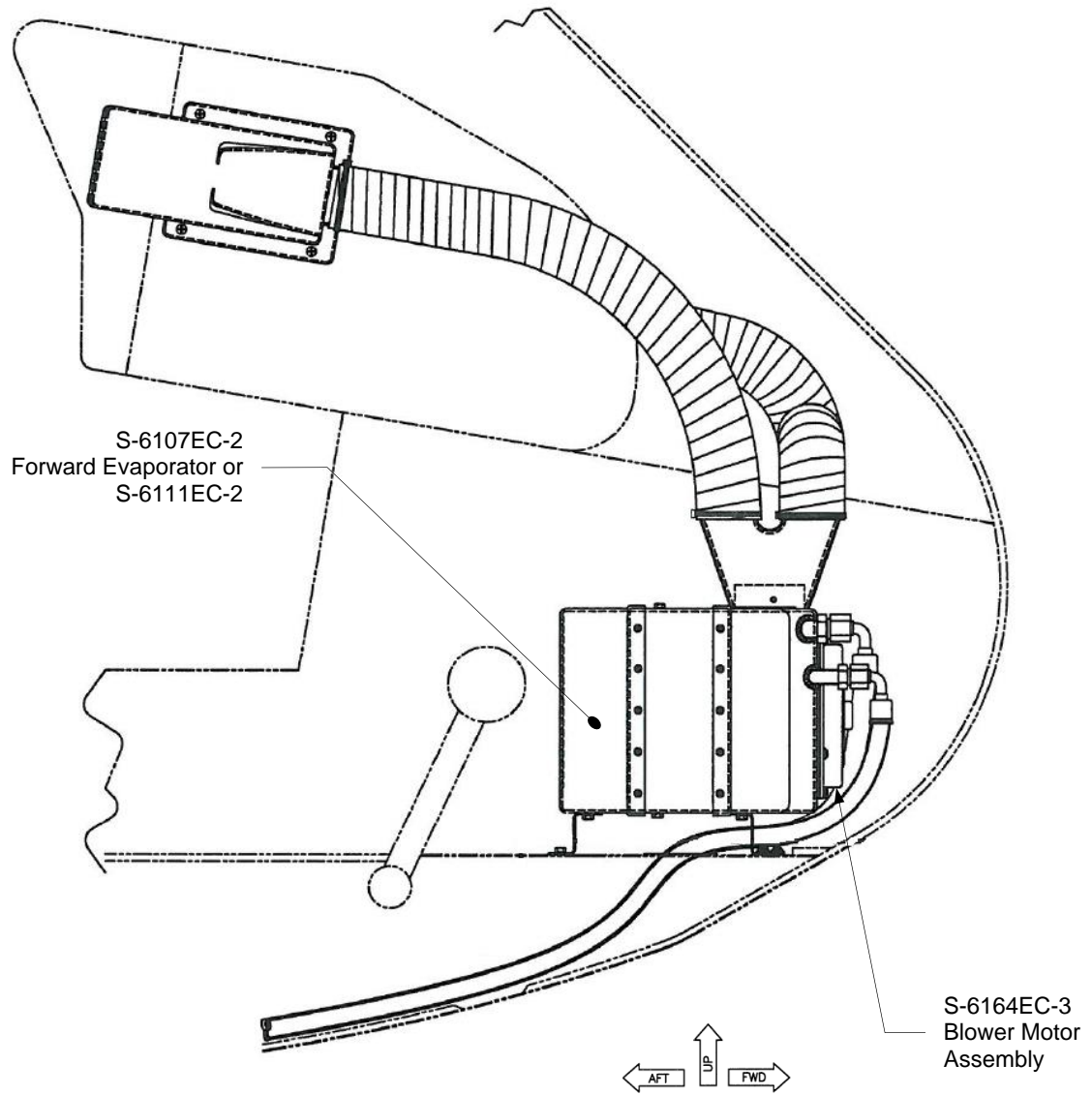
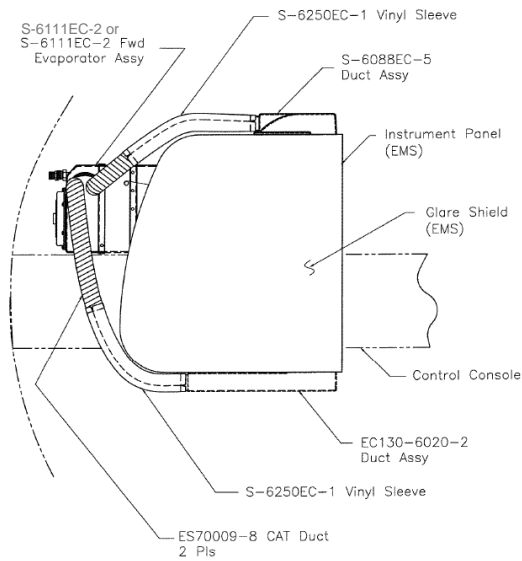

Figure 4-4 – Compressor Installation Poly-V Belt Configuration

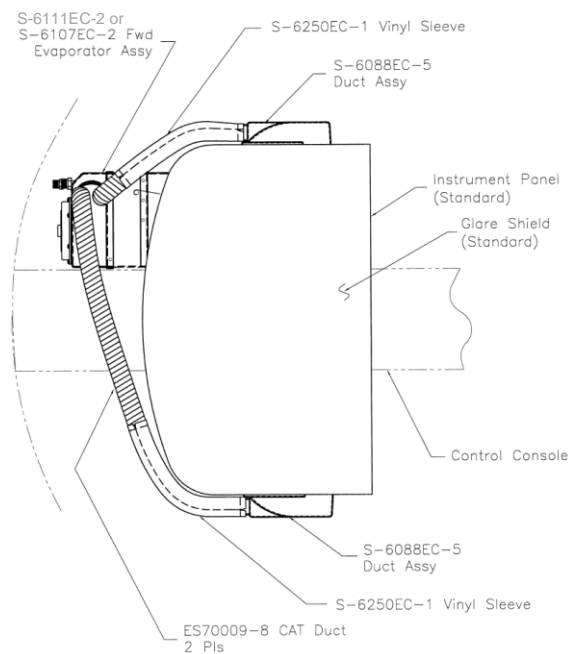



**Figure 4-5 – Forward Evaporator Installation  
(Lower Console – View Looking Inboard)**



**Figure 4-6**  
**Forward Evaporator Ducting (EMS)**  
**(Instrument Panel - View Looking Down)**



**Figure 4-7**  
**Forward Evaporator Ducting (Standard)**  
**(Instrument Panel - View Looking Down)**

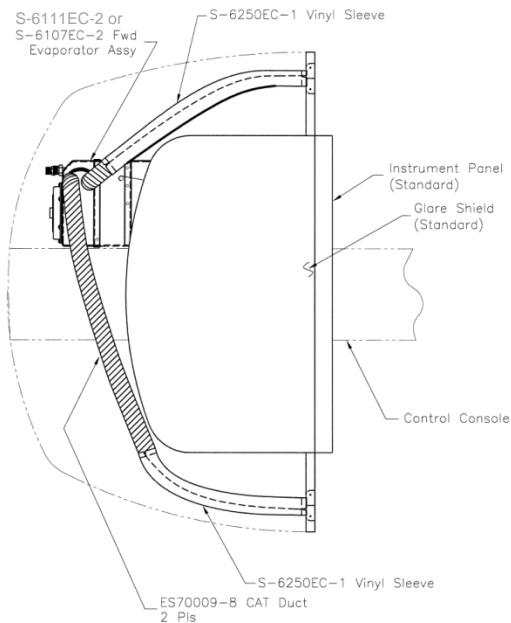

**Figure 4-8**  
**Forward Evaporator Ducting (Ball Louver)**  
**(Instrument Panel - View Looking Down)**

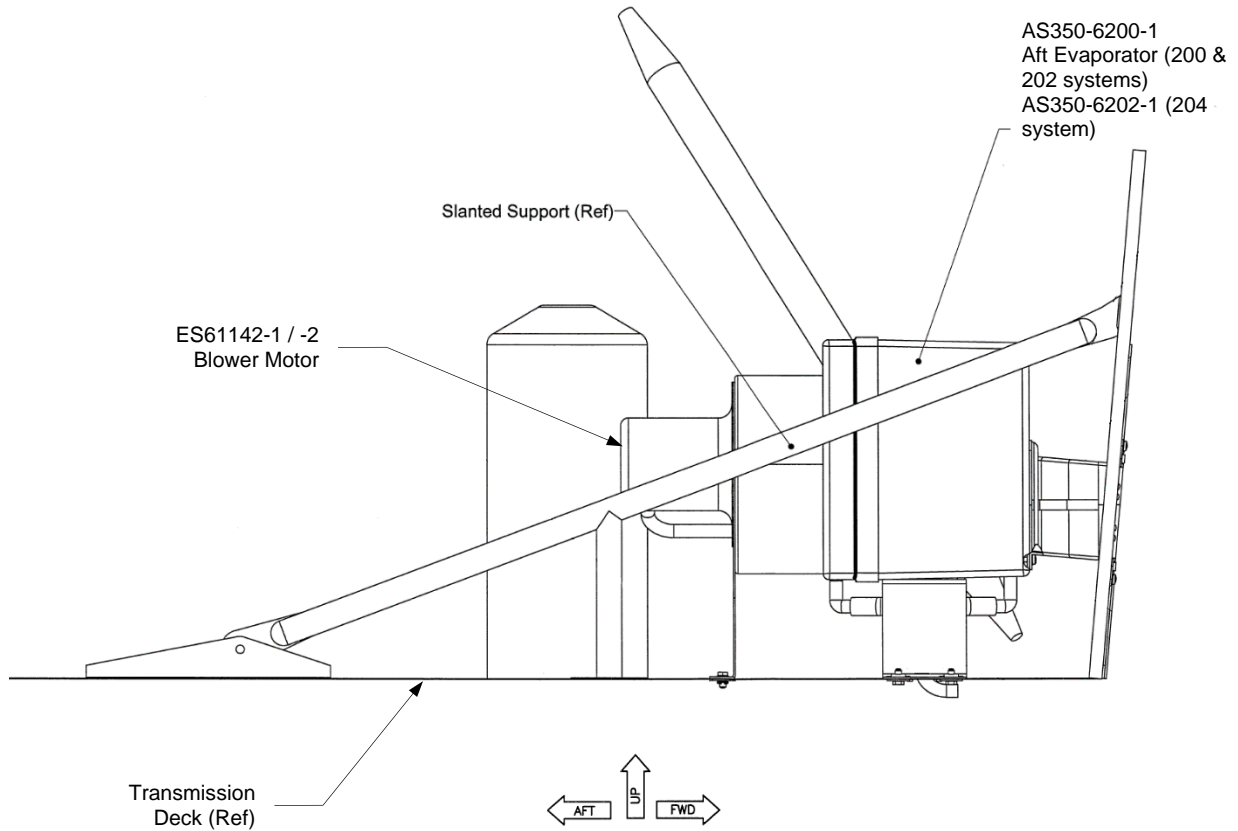

**Figure 4-9 – Aft Evaporator Installation  
(Transmission Deck – View Looking Inboard)**

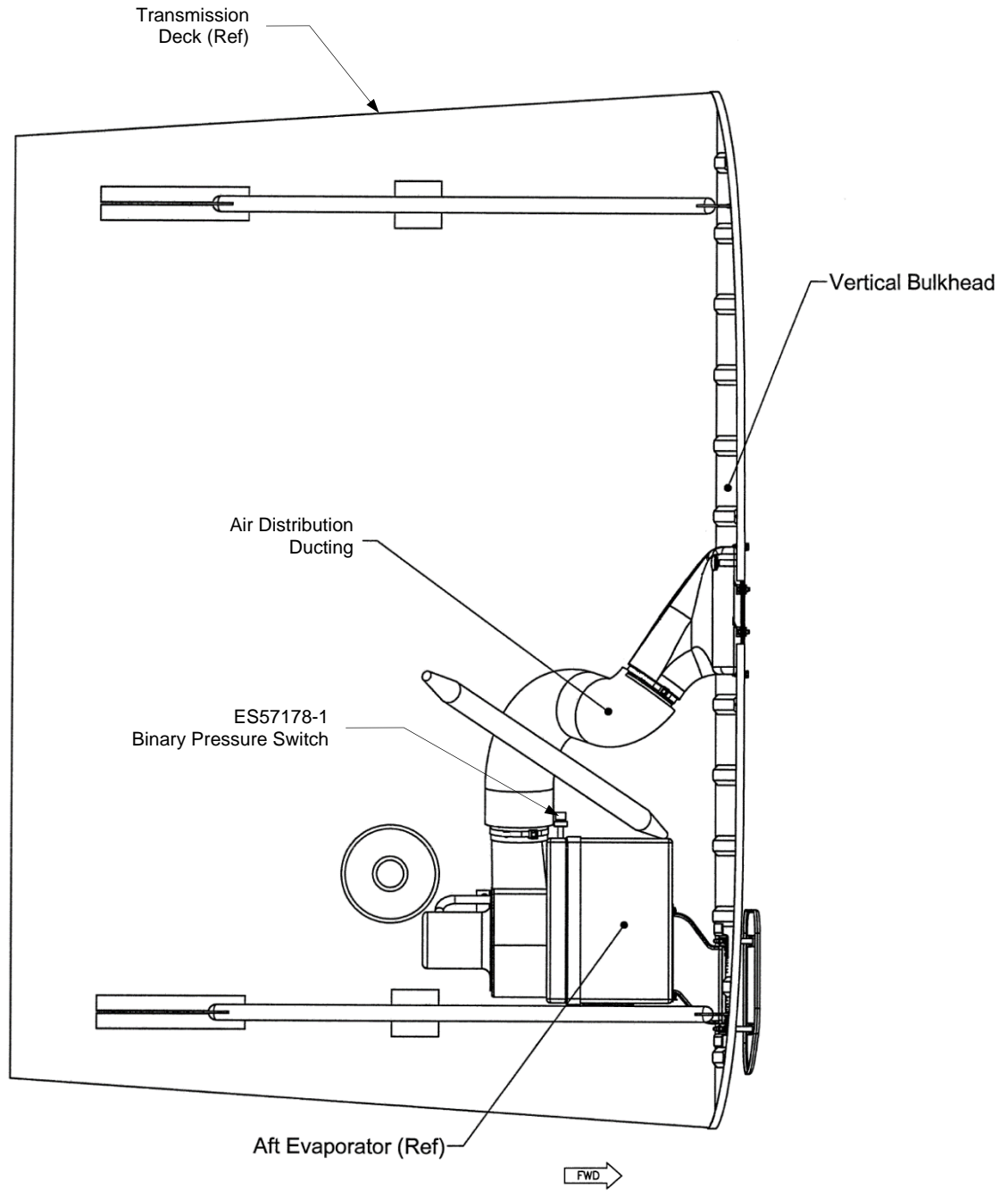

**Figure 4-10 – Aft Evaporator Air Distribution  
(Transmission Deck – View Looking Down)**

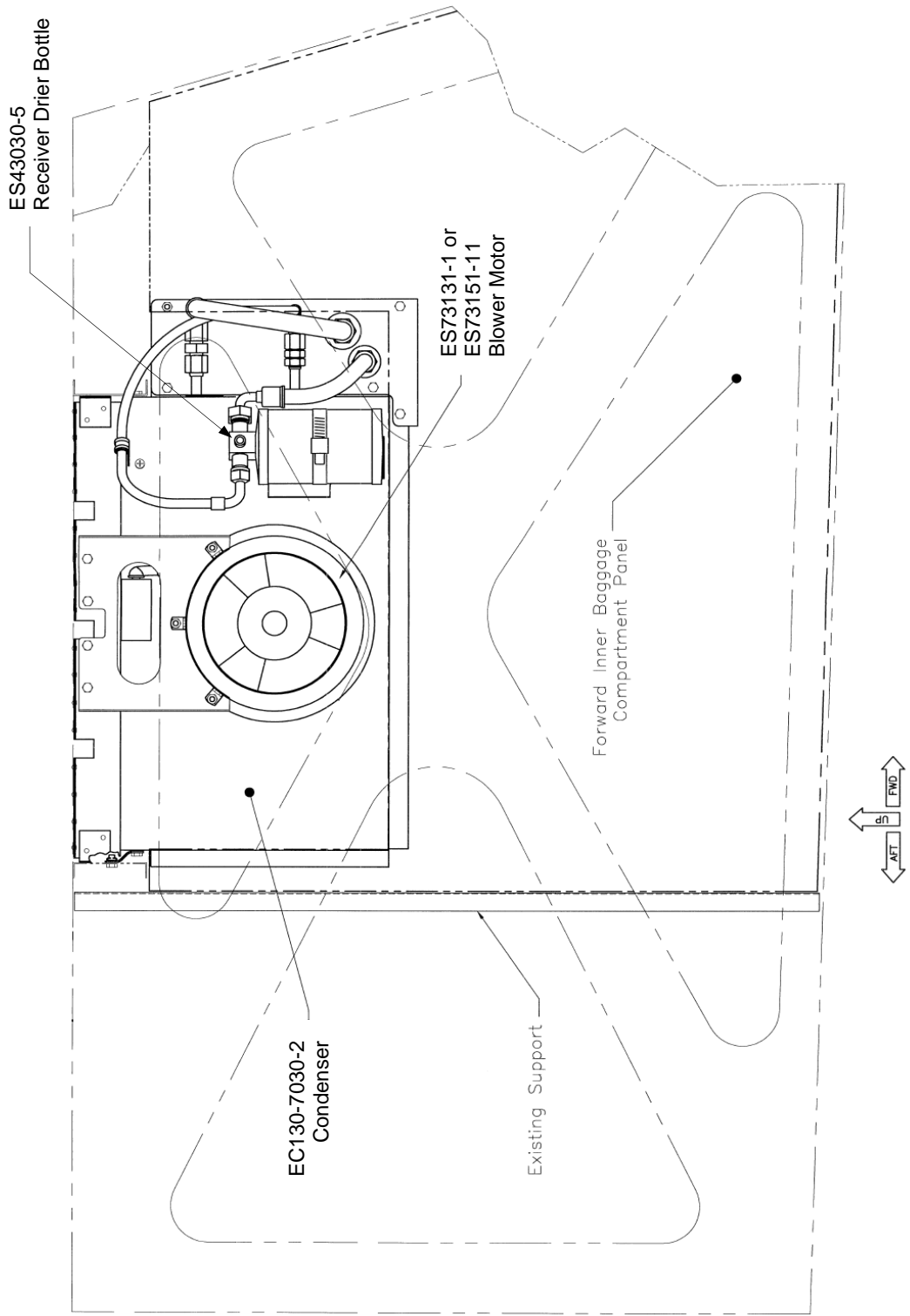

**Figure 4-11 – Baggage Compartment Condenser Installation  
(RH Baggage Compartment – View Looking Inboard)**

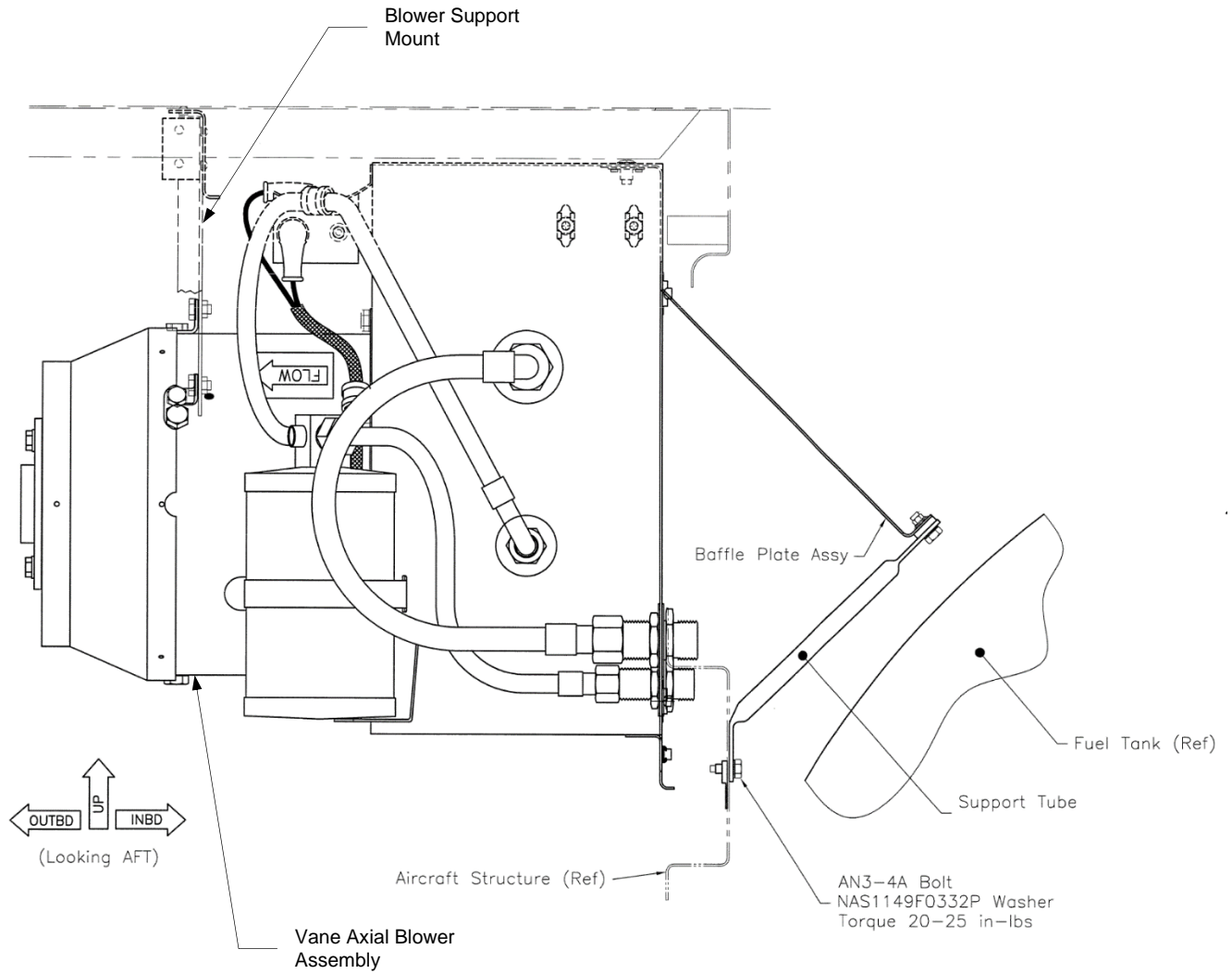

**Figure 4-12 – Baggage Compartment Condenser Installation  
(RH Baggage Compartment – View Looking Aft)**

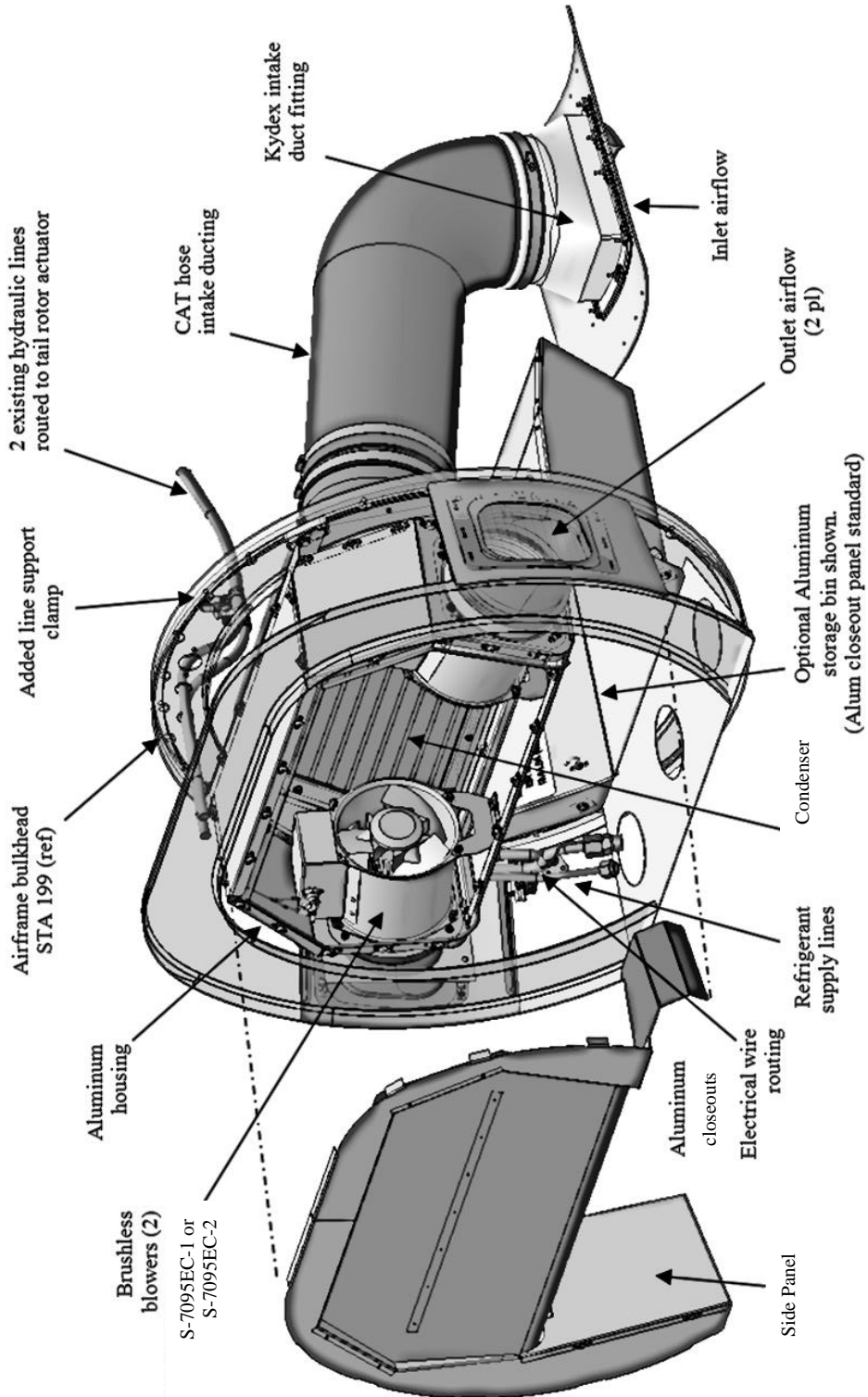

**Figure 4-13 – Tail Boom Condenser Installation  
(Tail Boom – View Looking Aft, Covers Removed to Reveal Details)**

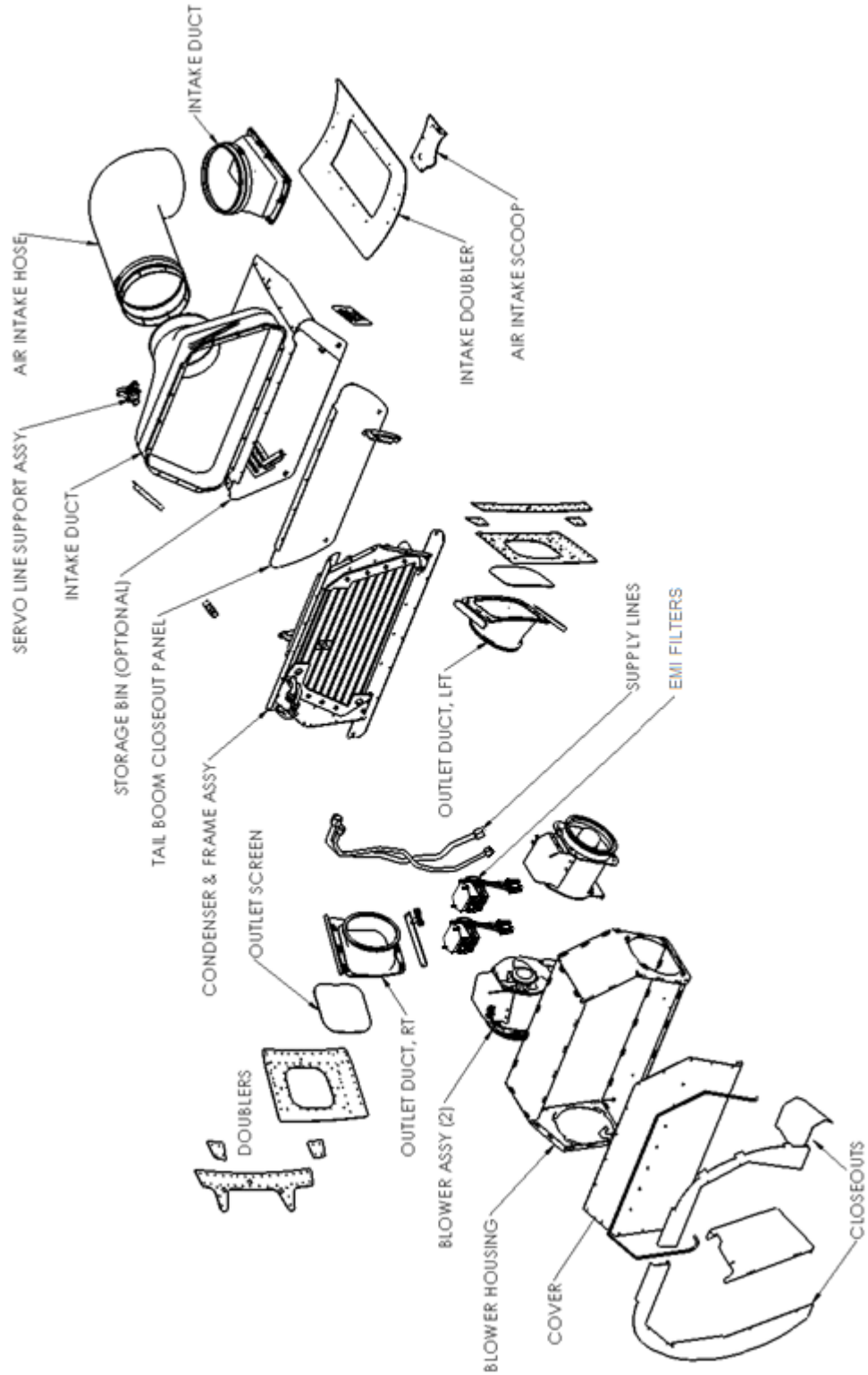

Figure 4-14 – Tail Boom Condenser Details



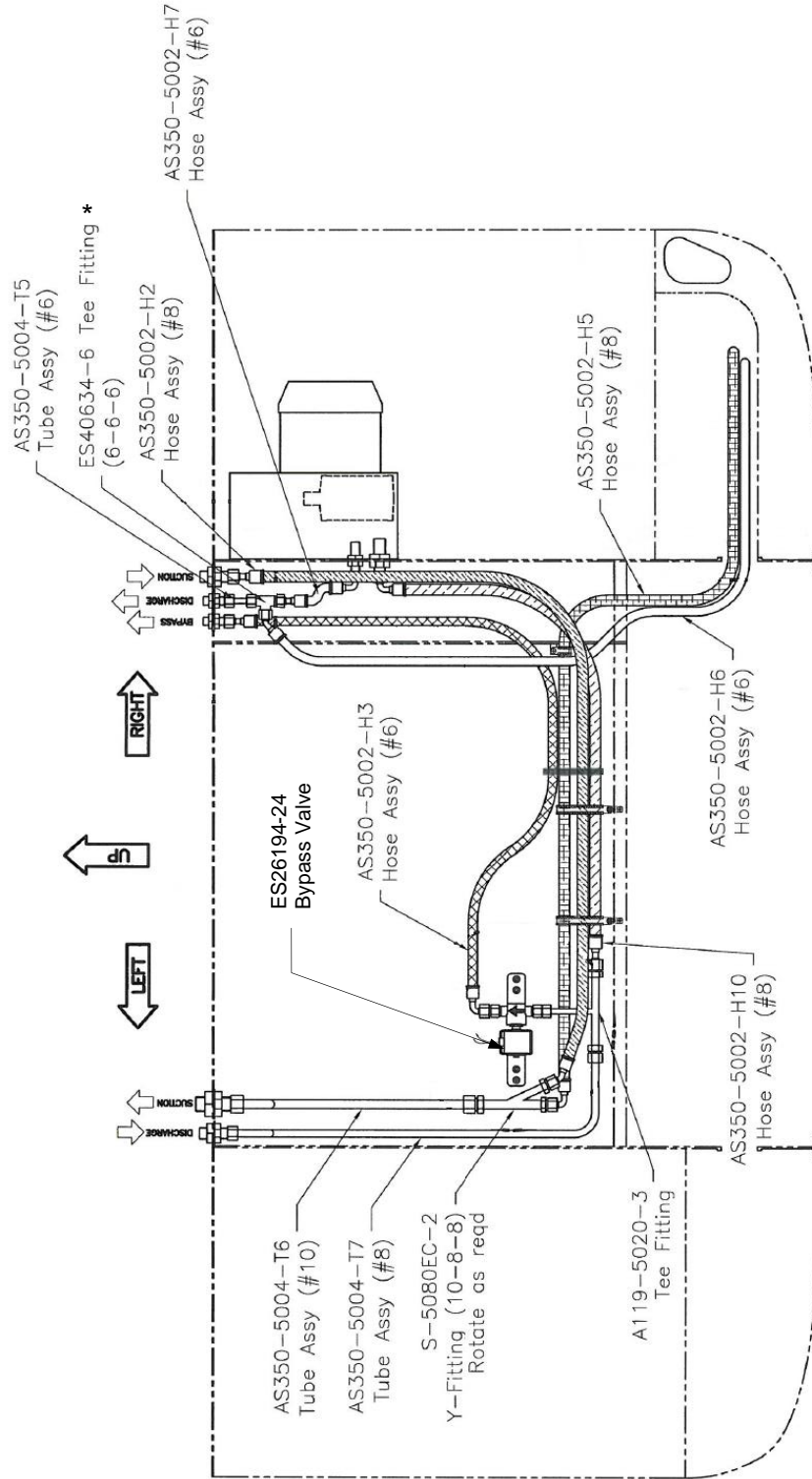

Figure 4-15 – Plumbing Installation, Side Mount Condenser (Aft Cabin Bulkhead – View Looking Forward)

\*For systems supplied after March 2014 the Tee fitting shown is replaced by ES40634-7 Tee fitting and ES49035-1 pressure relief valve

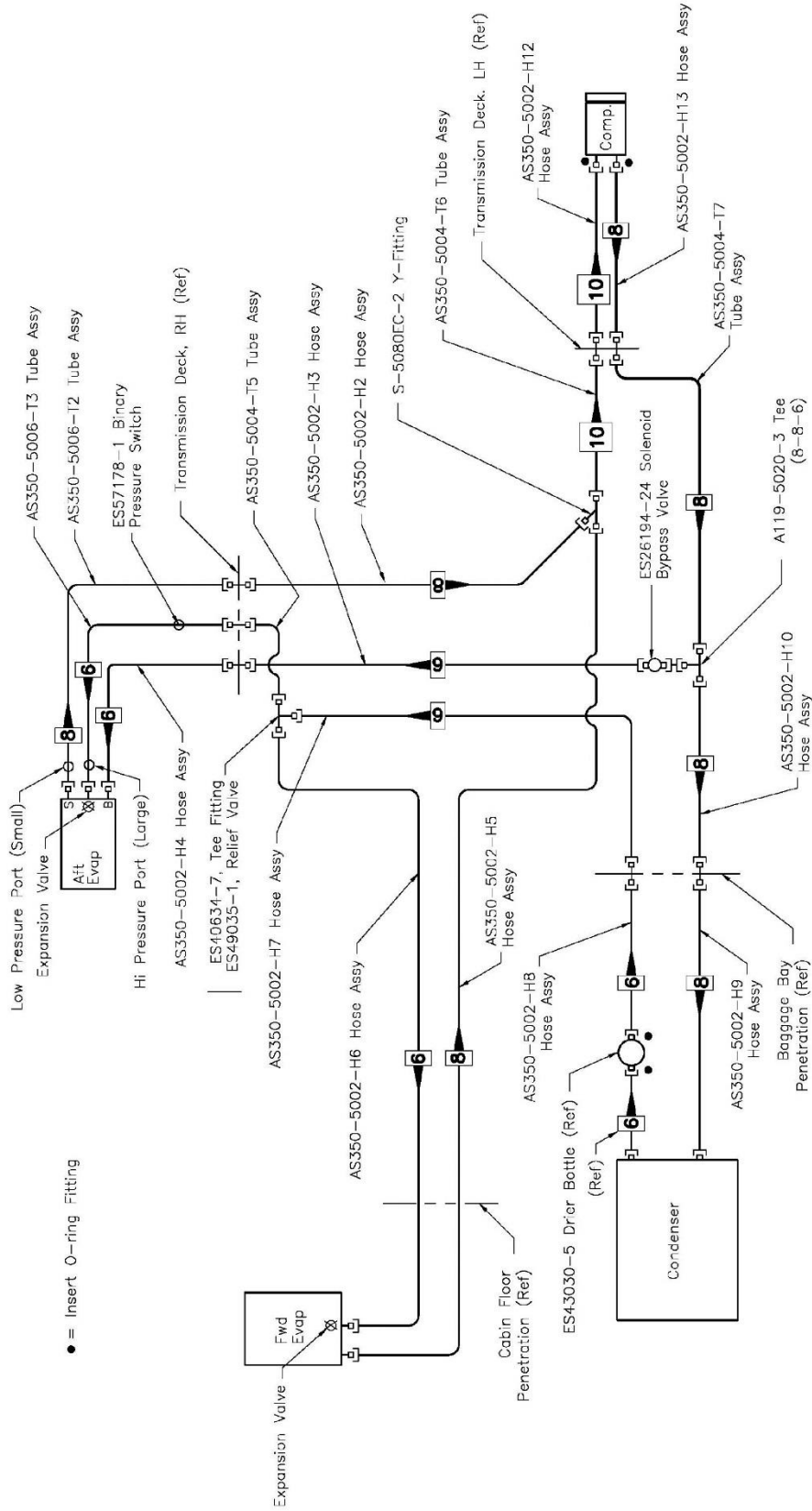

Figure 4-16 – Air Conditioning System Plumbing – Side Mounted Condenser

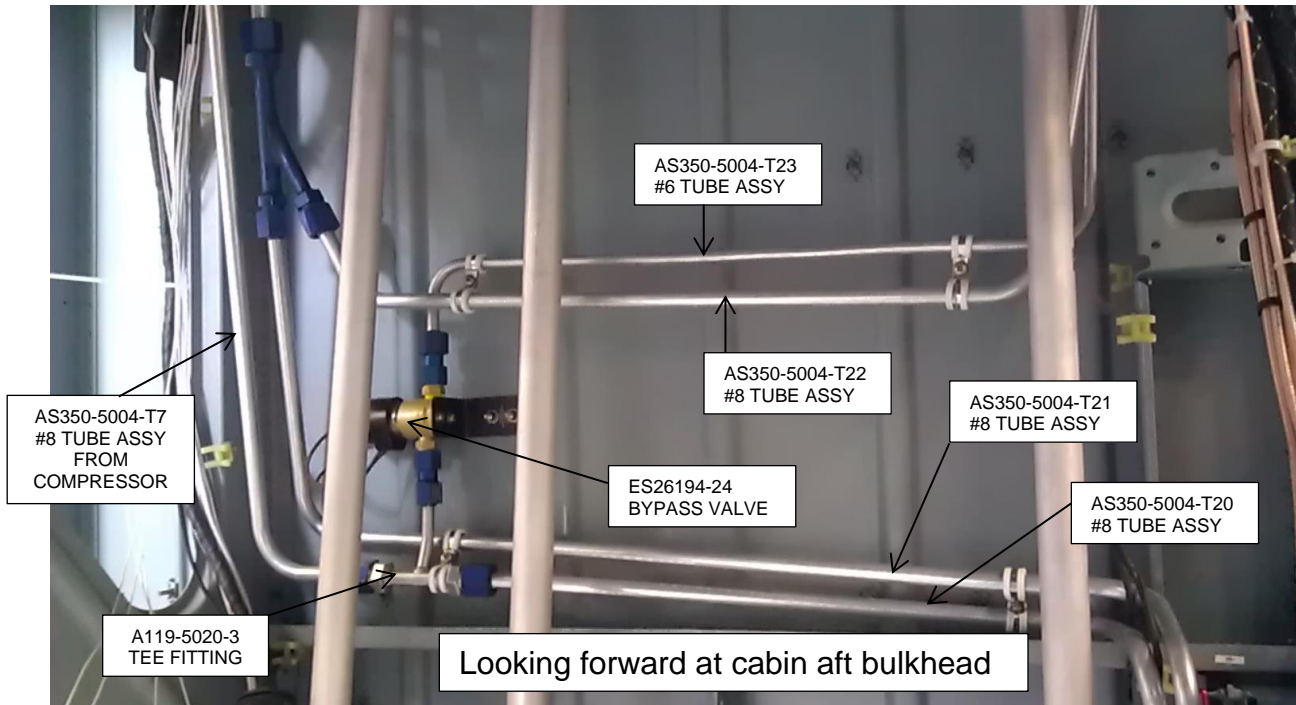

Figure 4-17 – Plumbing Installation, Tail Boom Condenser

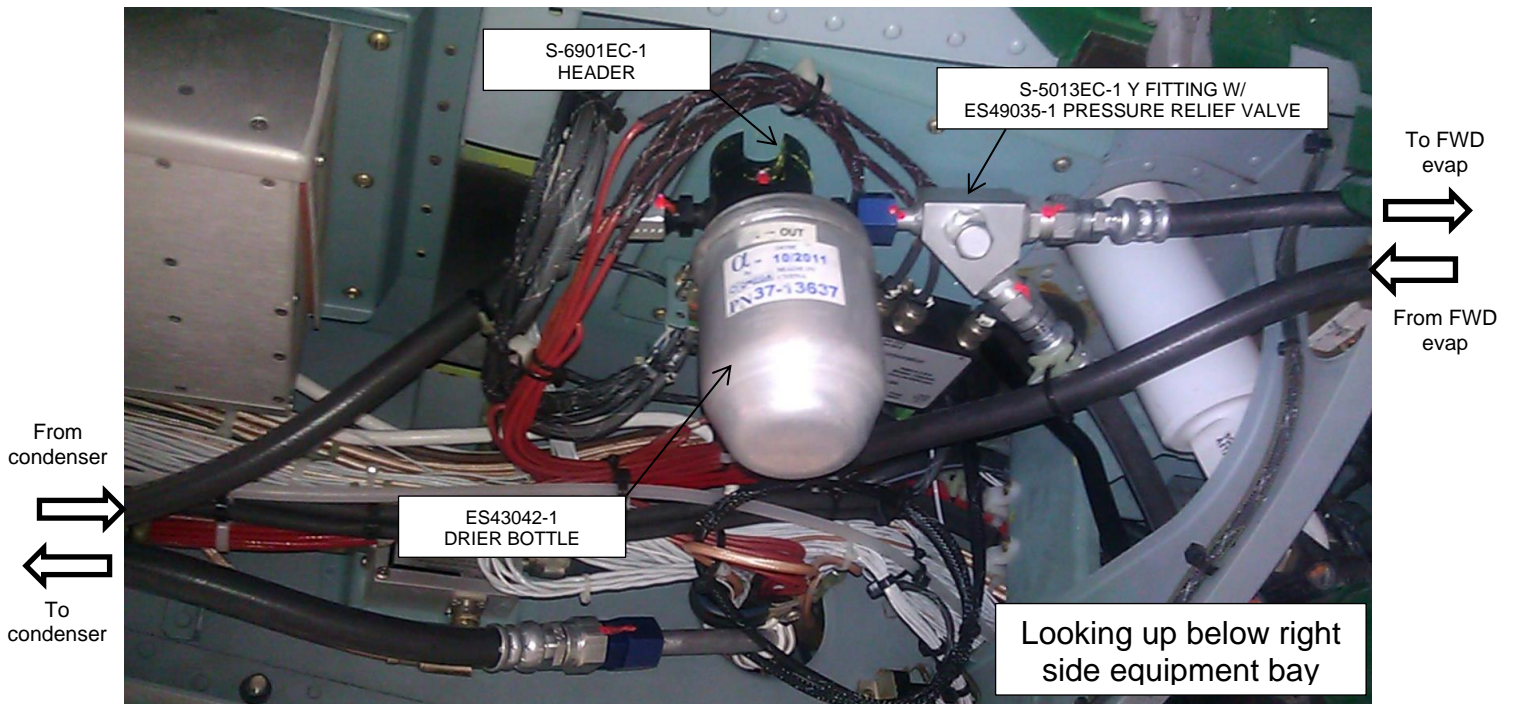

Figure 4-18 – Drier Bottle Installation, Tail Boom Condenser

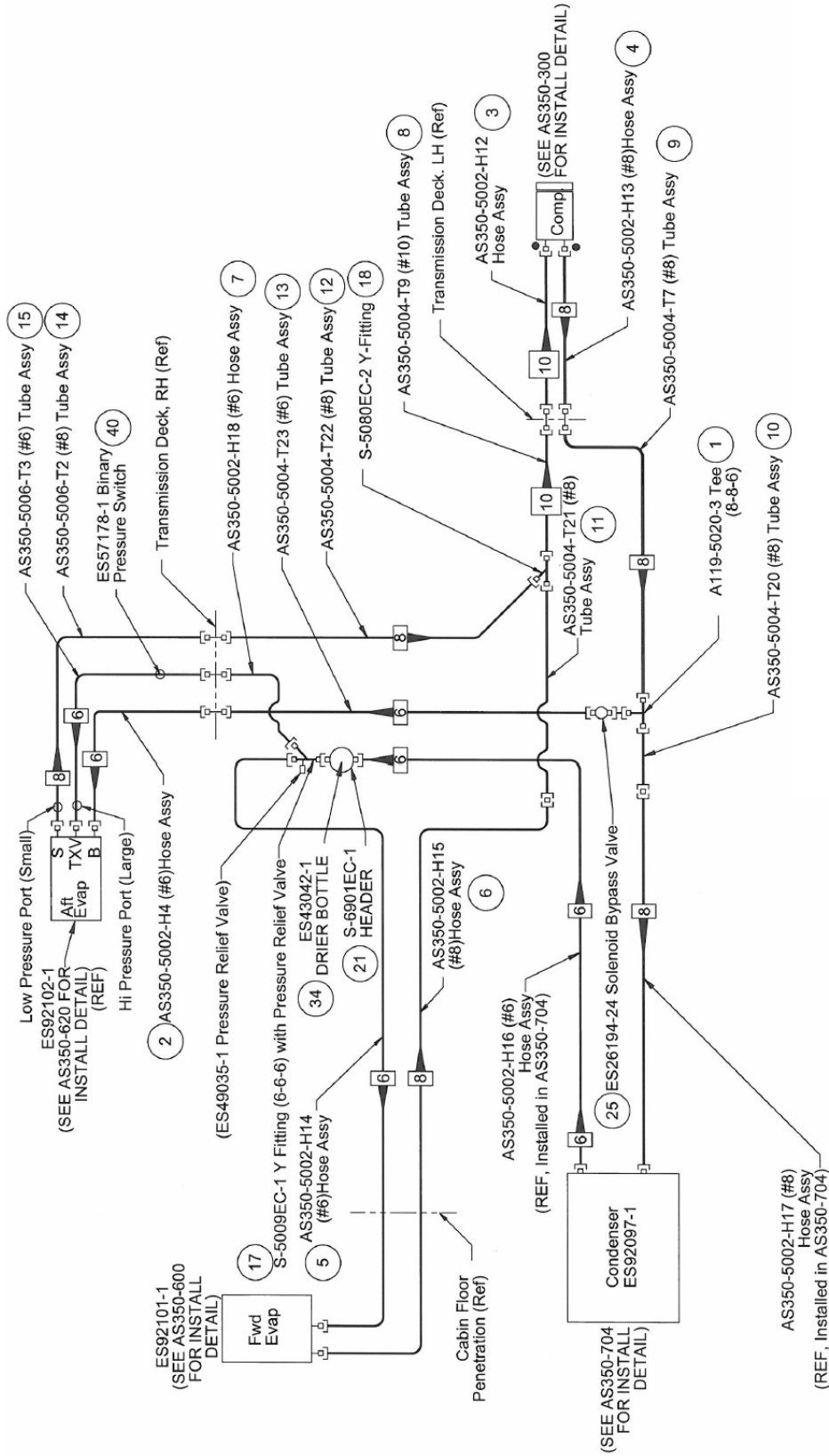
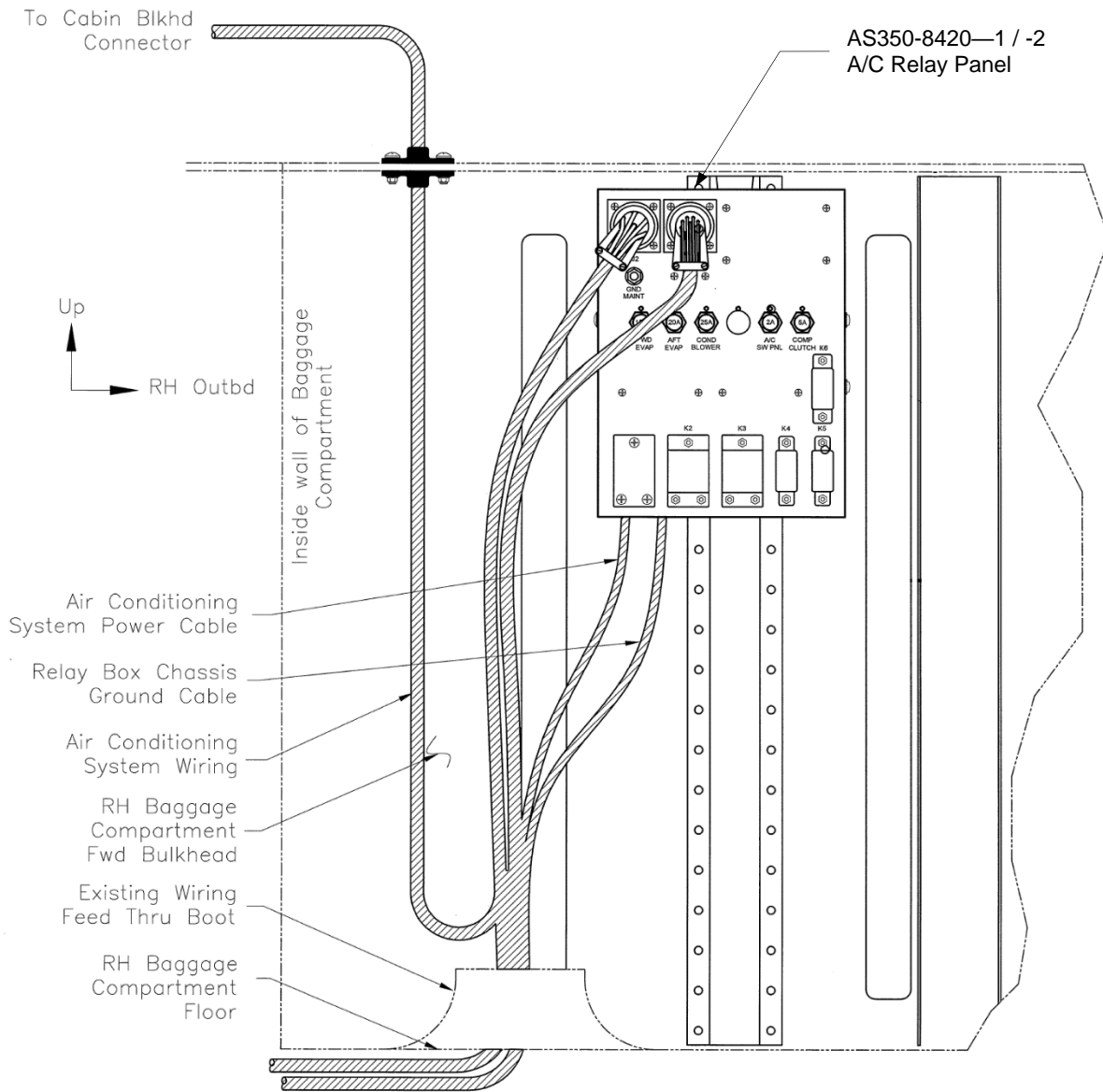

Figure 4-19 - Air Conditioning System Plumbing –Tail Boom Condenser



**Figure 4-20 – A/C Relay Panel Location  
(RH Baggage Compartment Forward Bulkhead – View Looking Fwd)**

**CHAPTER 5**  
**PLACARDS AND MARKINGS**

**1. Placard and Marking Information**

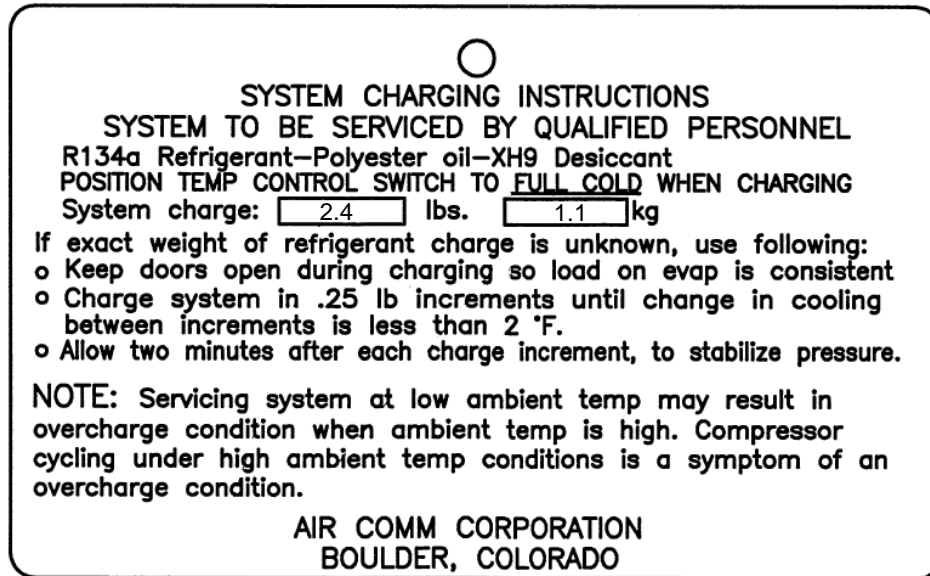

**Charging Instructions Placard**  
**(Transmission Deck Adjacent to Aft Evaporator)**

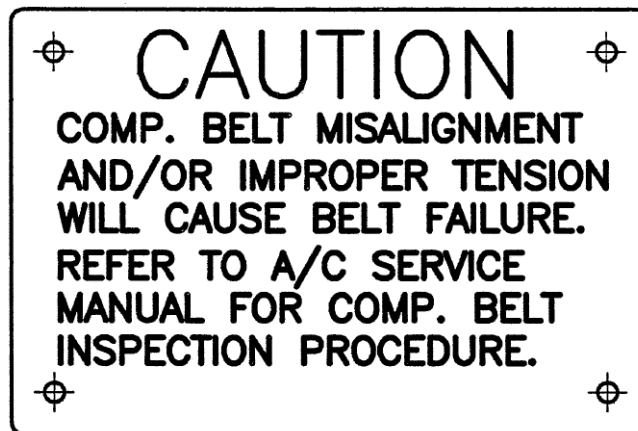

**Belt Alignment Caution Placard**  
**(Transmission Deck Adjacent to Compressor)**

**MAXIMUM BAGGAGE  
COMPARTMENT LOAD TO  
BE 130.0 LBS (59.0 KG)**

**WITH THE AIR COMM CORP.  
AIR CONDITIONING SYSTEM**

**Rear Baggage Compartment Placard (Located inside of the aft cargo door.)  
If equipped with the tail boom mounted condenser assembly**

**MAXIMUM STORAGE  
BIN LOAD TO BE  
10.0 LBS (4.5 KG)**

**Storage Bin Placard (Located inside right side of storage bin.)  
If equipped with the tail boom mounted condenser assembly and the optional storage bin  
located below the condenser**

## CHAPTER 6

### SERVICING

#### 1. Safety Precautions

##### CAUTION

Refrigeration servicing should be performed by qualified personnel only.

The refrigerant used in the air conditioning system is the environmentally safe HFC R134a. This refrigerant is non-explosive, non-flammable, and non-corrosive, has practically no odor, and is heavier than air. Although R134a is classified as a safe refrigerant, certain precautions must be observed to protect the parts involved and the person working on the system.

Liquid R134a at normal atmospheric pressure and temperature evaporates quickly and tends to freeze anything that it contacts. Care must be taken to prevent any refrigerant from coming into contact with the skin and the eyes.

##### WARNING

Always wear safety goggles when servicing any part of the refrigerant system. Should any liquid refrigerant contact the skin or eyes, seek medical attention immediately even if the irritation ceases.

##### WARNING

Never weld, use a flame-type leak detector, blow torch, solder, steam clean, bake on aircraft finish, or use excess amounts of heat on, or in the immediate area of refrigerant supply tank.

#### 2. Servicing Information

A list of suggested servicing equipment is provided later in this chapter.

##### **Servicing Procedure**

- A. Connect the service manifold and vacuum pump to the service ports located in the forward transmission area adjacent to the aft evaporator.
- B. Turn on the vacuum pump and open both valves to evacuate the system. When the pressure drops to 29.40 InHg (1.9 KgCm) moisture vaporizes and is drawn out of the system by the vacuum pump. Complete removal of moisture is important to prevent blockage of the expansion valves with ice. Leak check the system as described later in this chapter.

##### NOTE

Due to the drop in atmospheric pressure with an increase in altitude, the normal vacuum reading will drop approximately 1" InHg (1 KgCm) for each 1000 ft. (304.8 m) of altitude.



## AIR CONDITIONER SERVICE MANUAL AS350-200M-1

- C. After the system has been evacuated, turn off both manifold valves and turn the vacuum pump off. Allow a minimum of one hour to check for vacuum leaks (if the system will not hold a vacuum, the system has a fitting leak). It may be necessary to charge the system with one or two lbs. (.45 to .86 Kg.) of refrigerant and conduct a leak check survey using an electronic leak detector.

### **CAUTION**

It is mandatory that the system be leak free to insure trouble free operation. Continuous operation of the system with insufficient charge will result in reduced compressor life.

- D. After the system is proven to be leak free, the system should be evacuated for a minimum of 1/2 hour before being charged with HFC R134a.
- E. Charging the system with 2.4 lbs. (1.1 Kg.) of R134a refrigerant is the most accurate method of charging. This should be accomplished using the suggested servicing equipment called out in this chapter.
- F. If a charging station is unavailable, the following procedure should be followed. Add an initial refrigerant charge of 2.0 lbs. (0.9 Kg.) then continue to add refrigerant until the evaporator outlet air temperature and system suction pressures reach a minimum. When adding the refrigerant after the initial charge, it should be done in increments of 0.2 lbs. (.09 Kg.) and two minutes allowed to elapse before adding each additional 0.2 lbs. (.09 Kg.) refrigerant charge. The optimum charge occurs when evaporator outlet temperatures are at their lowest. Any additional refrigerant will cause the outlet air temperature to increase and system performance to be degraded.

### **WARNING**

If the system is to be charged by operating the compressor, it must be charged through the Lo (Blue fitting) pressure (suction) port only. Do not open the Hi (Red fitting) pressure (discharge) valve while the system is operating.

- G. Test-run the system after charging, to confirm the system is working properly.

### **CAUTION**

When reclaiming refrigerant be sure to note any oil that is removed from the system and replace the lost oil before or during re-servicing. Reduced compressor life will result if the total system oil charge is not maintained.

#### SYSTEM REFRIGERANT & OIL CHARGE

System Description	Refrigerant Charge		Oil Charge	
EC130 Air Conditioner system	2.4 lbs.	1.1 kg.	8.0 fl oz.	238 ml.

### **3. Lubrication Information**

The total system oil charge is 8.0 fl oz. (238 ml.) of Double End Capped Polyalkylene Glycol (DEC PAG). The oil is initially contained within the compressor as shipped from the factory so no additional oil is required when installing a new system.

If oil is spilled during installation / maintenance, or is lost due to a leak in the system, it is necessary to approximate the amount of lost oil and add this amount to the system. This oil, if required, should be added to the compressor discharge line prior to system charging.

This system may be serviced with either Polyolester (POE) or Double End Capped Polyalkylene Glycol (DEC PAG). Polyalkylene Glycol is preferred due to its superior lubricating properties and improved compressor service life. There are several types of PAG available. Only the "Double End Capped" type is permissible in Air Comm Corporation air conditioning systems. Double End Capped PAG oil is available from Air Comm Corporation in 8 ounce bottles (P/N ES94006-13). Mixing of POE and PAG is acceptable. Disregard previous statements to the contrary. They referenced PAG oil that was not "Double End Capped". Current versions of compressors are designed to be operated using PAG oil. Testing by Air Comm Corporation has shown that "Double End Capped" PAG is compatible with POE and can therefore be mixed. "Double End Capped" is a reference to the chemical structure of the molecule and not to the container.

(Do not use Mineral oil in this system with R134a refrigerant. Do not use any refrigerant oil other than Double End Capped Polyalkylene Glycol (also known as "ULTRA PAG") or Polyolester (also POE)).

Containers of DEC PAG or POE will absorb moisture if left open (hygroscopic). Keep containers tightly capped when not in use and keep all system components capped while servicing system.

The quantity of lubrication in the system is critical. If too little lubrication is in the system the compressor life may be reduced. No other component in the A/C system requires lubrication. Too much lubricant in the system will retard heat transfer in the evaporator and condenser coils and reduce the cooling capacity of the system.

#### **NOTE**

Maintaining the correct amount of refrigerant and refrigerant oil in the system is critical for ensuring the long life of the compressor.

The Service Ports for this system are located in the forward transmission deck area adjacent to the aft evaporator.

#### **CAUTION**

This system is serviced with either Polyester Based Refrigerant Oil (POE) or Double end capped Polyalkylene oil (DEC PAG, aka Ultra PAG). The use of Mineral Oil or Polyalkylene (PAG) in this system will cause damage to the air conditioner compressor and expansion valves.

The following chart may be used to calculate the amount of oil to be added in case a component is being replaced with a new part.

Component	Oil Amount
Compressor	See Instructions
Evaporator	1.0 oz. per evaporator
Condenser	1.5 oz.
Receiver Drier	1.5 oz.
Hose - Vapor	1.0 oz. per 10 foot
Hose – Liquid	1.0 oz. per 20 foot

**4. System Leak Check**

Identification and elimination of system fitting leaks is extremely important to insure a trouble-free operation of this system.

A system which contains a partial charge of refrigerant can be leak tested with the aid of an electronic leak detector, and be recharged without evacuating the system.

A new or empty system can be pressurized with nitrogen 70-80 psi (5.1-5.6 kg/cm) or R134a 50 psi (3.5 kg/cm) to conduct a leak survey.

**CAUTION**

Do not use compressed air. Compressed air will introduce moisture into the system, which will degrade the operation of the system.

The preferred method to conduct a leak survey is to use an electronic leak detector in conjunction with a small charge of R134a refrigerant. All checks done in this manner should be conducted with the air conditioner off. Since the refrigerant is heavier than air, leaks are most likely to be detected on the underside of hoses and fittings. Refrigerant will collect in low areas and provide erroneous leak detection. A stream of compressed air from a nozzle may be useful in clearing the area just prior to conducting a leak test.

If the nitrogen method is used, it will be necessary to mix together a water and mild soap solution. Each fitting or suspected leak area should be brushed with this soap solution and watched for evidence of bubbles formed by the escaping nitrogen.

If a leak is detected at an O-ring fitting, check to insure proper torque has been applied to the fitting. If the system continues to leak, reclaim the system of refrigerant, and install new O-rings.

**NOTE**

Ensure that the O-ring is lubricated with refrigerant oil prior to its installation.

A small amount of leakage (approximately one ounce per year) past the compressor shaft seal is normal. Most leak detectors are sensitive enough to show a leak of this magnitude.

**5. Suggested Equipment for Servicing**

Recovery / Recycling / Recharging Station  
(Example: Snap-on Model ACT 3340, Robinair Model 34700, or equivalent)

Electronic Leak Detector (R134a compatible)  
(Example: Micro-Tech III, Robinair, Snap-on, or equivalent)

Manifold and gauge set (R134a compatible)  
(Example: Robinair, Snap-on, or equivalent)

**6. Consumable Materials**

Refrigerant:  
This system is to be charged with Dupont, or equivalent HFC R134a refrigerant only.

Lubricant:  
This system may be serviced with either Polyolester (POE) or Double End Capped Polyalkylene Glycol (DEC PAG). DEC PAG is preferred.

**CAUTION**

**Do *not* use Polyalkylene glycol (PAG) or Mineral Oil in this system.**

O-rings:  
As this system is charged with R134a refrigerant, it must be fitted with Highly Saturated Nitriles (HSN) O-rings. This system incorporates two different O-ring fittings, Torq-Lok and Insert. The HSN O-rings for the Torq-Lok fittings are BLACK in color and the HSN O-ring for the Insert fittings are GREEN in color.

**7. Suggested Spares List**

<u>Item</u>	<u>Part Number</u>
Blower Motor – Fwd. Evaporator	S-6164EC-3
Blower Motor – Aft Evaporator	ES61142-1, -2
Blower Assembly – Condenser (Baggage)	EC130-7536-2
Blower Assembly – Condenser (Tail Boom)	S-7095EC-1 (Alt S-7095EC-2)
Compressor Assembly (Flat Belt)	S-3048EC-1
Compressor Drive Belt (Flat)	ES35350-3
Compressor Assembly (Ploy V Belt)	S-3036EC-1
Compressor Drive Belt (Poly V)	ES35130-3
Receiver / Drier Bottle	ES43030-5 (200 / 202 systems) ES43042-1 (204 system)
Binary Switch	ES57178-1
By-pass Valve	ES26194-24
EMI Filter	AS350-8424-1
HSN O-rings; Insert type (Green)	
<u>Size</u>	
#6 O-ring	ES44010-2
#8 O-ring	ES44010-3
#10 O-ring	ES44010-4
HSN O-rings; Torq-Lok Type (Black)	
<u>Size</u>	
#6 O-ring	ES44012-2
#8 O-ring	ES44012-3
#10 O-ring	ES44012-4

**CHAPTER 7**  
**STANDARD PRACTICES AND INFORMATION**

**1. General Information**

- a. Refer to Airbus Model AS350 Maintenance Manual for general removal and installation procedures associated with basic aircraft equipment and components.
- b. It may be necessary to evacuate (discharge) refrigerant from the system to remove or replace certain components. Instructions for servicing are found in Chapter 6.
- c. All openings and ports in components, hoses, and tubes disconnected or removed to facilitate removal and replacement procedures must be capped or plugged to prevent contamination.
- d. Retain all parts and attaching hardware for reassembly, unless otherwise noted.

**2. Fitting Torque Procedures**

INSERT O-RING FITTINGS

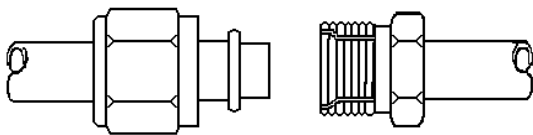

TORQ-LOK FITTINGS

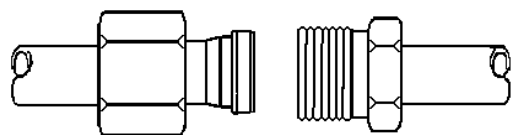

Apply a thin coating of refrigerant oil to O-ring and Female side of fitting. Confirm there is no damage (nicks, dirt, etc.) on fittings.

Slide B-nut back away from the end of the tube so you can see the O-ring as you slide the fitting together.

Be careful not to pinch O-ring during assembly.

Engage the male end into the female fitting being careful to maintain alignment.

The male flange should seat fully against the female fitting without the O-ring being pinched.

It is important to hold the fitting together while sliding the B-nut forward and engaging the threads.

Tightening specifications

**CAUTION: ALWAYS USE BACK UP WRENCH. EXCESSIVE TORQUE WILL DAMAGE THE JOINT, COMPROMISING THE INTEGRITY OF THE SEAL.**

Insert O-Ring Fittings (regardless of size): Hand tighten, then turn an additional 60 deg. (one flat on the nut).

TORQ-LOK<sup>®</sup> fittings (regardless of size): Hand tighten, then turn an additional 30 deg.

INSERT O-RING FITTINGS

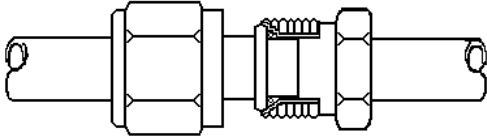

TORQ-LOK FITTINGS

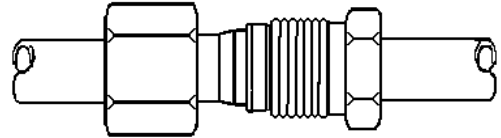

Once the system is charged, check each fitting with an electronic leak detector.

(An electronic leak detector is the only reliable method of checking for refrigerant leaks)  
Once the fittings have been checked and are found to be free of leaks, torque seal as appropriate.

### **3. Removal and Replacement of Forward Evaporator Assembly** **(see Figure 4-5)**

#### Removal

- a. Remove LH and RH outlet flex ducts from the Y-adapter on evaporator by removing cable ties.
- b. Remove attaching hardware securing evaporator assembly to aft support bracket. Lift and slide evaporator aft enough to access drain line and refrigerant lines.
- c. Disconnect drain line from bottom of evaporator by removing cable tie.
- d. Evacuate the refrigerant from the system. Refer to Chapter 6 Servicing p.30.
- e. Disconnect refrigerant plumbing from evaporator fittings. Always use a back-up wrench.
- f. Disconnect blower motor electrical connector.
- g. Remove forward evaporator assembly.

#### Replacement

- a. Position evaporator and connect blower motor electrical connector and secure as needed.
- b. Connect drain line at bottom of evaporator and secure with cable tie.
- c. Replace all O-rings before connecting refrigerant plumbing to evaporator fittings using a back-up wrench. Torque refrigerant line connections per section 2 p.36.
- d. Slide evaporator until forward support tab fully engages into forward mount. Secure evaporator with attaching hardware to aft support bracket.
- e. Connect LH and RH outlet flex ducts to Y-adapter on evaporator and secure with cable ties.
- f. Service air conditioning system with refrigerant per Chapter 6, p.30.

**4. Removal and Replacement of Forward Evaporator Blower Motor Assembly (Figure 7-1 below)**

Removal

- a. Remove forward evaporator as per paragraph 2.
- b. Disconnect blower motor electrical connector.
- c. Remove attaching hardware securing blower motor assembly to evaporator enclosure. Remove blower motor assembly.
- d. Loosen retaining set screw and remove blower wheel from blower motor shaft. Retain blower wheel.

**NOTE**

It may be necessary to apply heat to the set screw of the blower wheel in order to separate the two parts.

Replacement

- a. Install retained blower wheel on new motor. Press the blower wheel onto the motor shaft until it stops against motor. Back blower wheel away to achieve a .030" – .040" clearance between blower wheel and new motor. Apply one drop of low strength Loctite to set screw and tighten against flat portion of motor shaft to lock wheel in place.
- b. Install blower motor in evaporator enclosure and secure with attaching hardware.
- c. Connect blower motor electrical connector and secure as needed.
- d. Install forward evaporator as per paragraph 2.

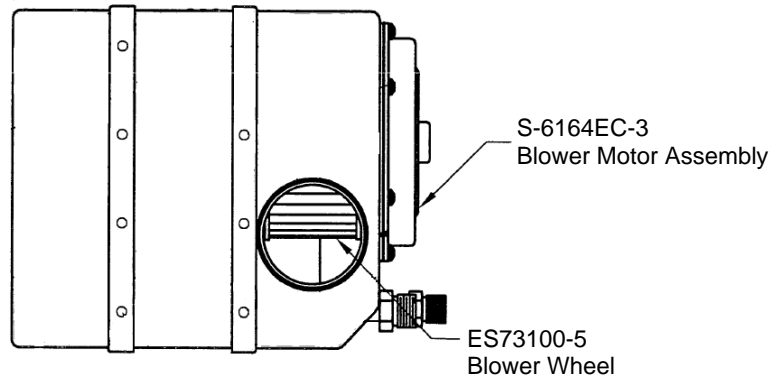

**Figure 7-1 – Forward Evaporator**



**5. Removal and Replacement of Aft Evaporator Assembly**  
**(Figure 4-9 & 4-10)**

Removal

- a. Disconnect refrigerant plumbing from evaporator fittings once refrigerant is evacuated. Always use a back-up wrench.
- b. Remove attaching hardware and disconnect duct from inlet of evaporator. Remove flex duct from outlet of evaporator by removing cable ties.
- c. Remove attaching hardware securing evaporator assembly to transmission deck.
- d. Disconnect drain line from bottom of evaporator by removing cable tie.
- e. Disconnect wiring harness connector to evaporator assembly.
- f. Remove aft evaporator assembly.

Replacement

- a. Position evaporator and connect drain line at bottom of evaporator. Secure with cable tie.
- b. Mount evaporator and secure with mounting hardware to transmission deck.
- c. Connect duct and flex duct to inlet and outlet of evaporator and secure with attaching hardware and cable ties. Seal duct joint to evaporator with black RTV.
- d. Connect wiring harness connector to evaporator.
- e. Replace all O-rings before connecting refrigerant plumbing to evaporator fittings using a back-up wrench. Torque refrigerant line connections per section 2, p.36.
- f. Service air conditioning system with refrigerant per Chapter 6, p.30.

**6. Removal and Replacement of Aft Evaporator Blower Motor**  
**(Figure 7-2 below)**

Removal

- a. Disconnect blower motor electrical connector.
- b. Remove attaching hardware securing blower assembly and cup housing to aft evaporator enclosure.
- c. Remove attaching hardware securing blower and blower wheel to cup housing. Remove blower assembly.
- d. Loosen retaining set screw and remove blower wheel from blower motor shaft. Retain blower wheel.
- e. Remove heat shrink and splices to motor wires. Retain Molex receptacle and wiring.

**NOTE**

It may be necessary to apply heat to the set screw of the blower wheel in order to separate the two parts.

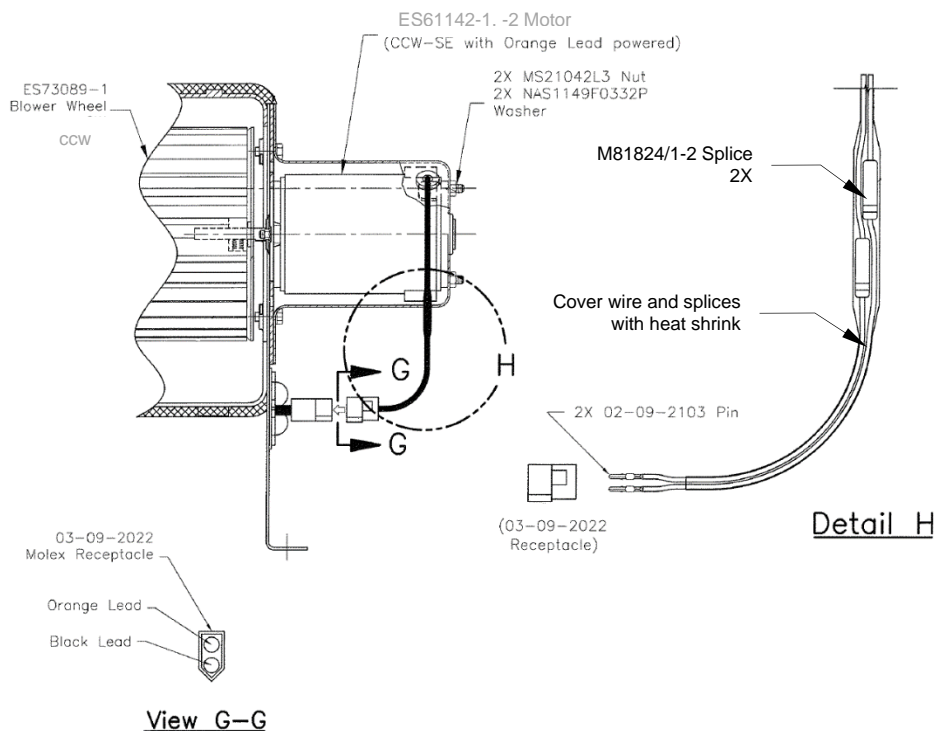

**Figure 7-2 – Aft Evaporator Blower Motor, Pre-2015 kits with Molex connectors**

Replacement

- a. Install splices to retain Molex receptacle wiring and replacement motor wires. Cover with heat shrink. Ensure wiring polarity is observed as per Figure 7-2.
- b. Install retained blower wheel on new motor. Press the blower wheel onto the motor shaft until it stops against motor. Back blower wheel away to achieve a .030” – .040” clearance between blower wheel and new motor. Apply one drop of low strength Loctite to set screw and tighten against flat portion of motor shaft to lock wheel in place.
- c. Attach motor and blower wheel to cup housing using attaching hardware.
- d. Install blower assembly and cup housing to aft evaporator enclosure using attaching hardware.
- e. Connect blower motor electrical connector and secure as needed.

**7. Removal and Replacement of Condenser Assembly (Side Baggage Compartment) (Figure 4-11 & 4-12)**

Removal

- a. Remove attaching hardware securing forward inner baggage compartment panel to condenser assembly. Remove baggage compartment panel.
- b. Disconnect refrigerant plumbing from condenser fittings once refrigerant is evacuated. Always use a back-up wrench.
- c. Remove attaching hardware securing blower support mount to condenser vane axial blower assembly.

- d. Remove lower attaching hardware securing baffle plate assembly support tube to aircraft structure.
- e. While supporting condenser assembly, remove attaching hardware securing condenser hangar brackets on each side of condenser to existing horizontal support.
- f. Remove condenser assembly.

Replacement

- a. Position condenser and secure with attaching hardware to hangar brackets on each side of condenser to existing horizontal support.
- b. Install lower attaching hardware securing baffle plate assembly support tube to aircraft structure. Torque support tube bolt to 20-25 in-lbs (2.25-2.82 Nm)
- c. Secure blower support mount to condenser vane axial blower assembly with attaching hardware.
- d. Replace all O-rings before connecting refrigerant plumbing to condenser fittings using a back-up wrench. Torque refrigerant line connections per section 2 p.36.
- e. Install forward inner baggage compartment panel to condenser assembly.
- f. Service air conditioning system with refrigerant per Chapter 6, p.30.

**8. Removal and Replacement of Condenser Blower Assembly (Side Baggage Compartment) (Figure 4-11 & 4-12)**

Removal

- a. Disconnect blower assembly wiring from RF filter. Observe position and polarity of the wires for reinstallation.
- b. Remove attaching hardware that secures condenser blower assembly housing to condenser assembly.
- c. The discrepant blower assembly can be returned for core exchange credit. Contact ACC Customer Service for instructions.

Replacement

- a. Install blower assembly to condenser assembly with attaching hardware.
- b. Connect blower wiring to RF filter and secure as needed. Observe polarity of the wires (Black – negative; Red – positive).

**9. Removal and Replacement of Condenser Assembly (Tail Boom) (Figure 4-13)**

Removal

- a. Remove attaching hardware from condenser cover panel. Remove panel.
- b. Remove both condenser blower assemblies per section 10 below.
- c. Remove both blower lower support brackets attached to the exhaust duct tray.
- d. Disconnect refrigerant plumbing from condenser fittings once refrigerant is evacuated. Always use a back-up wrench.
- e. Remove 7 nuts securing condenser assembly.

- f. Remove both foam lined air block panels.
- g. Remove condenser assembly.

Replacement

- a. Position condenser and air block panels and secure with attaching hardware.
- b. Replace all O-rings before connecting refrigerant plumbing to condenser fittings using a back-up wrench. Torque refrigerant line connections per section 2 p.36.
- c. Install both condenser blower assemblies with support brackets.
- d. Install condenser assembly cover panel to condenser assembly.
- e. Service air conditioning system with refrigerant per Chapter 6, p.30.

**10. Removal and Replacement of Condenser Vane Axial Blower (Tail Boom) (Figure 4-13)**

Removal

- a. Remove attaching hardware condenser assembly cover panel to condenser assembly. Remove cover.
- b. Disconnect condenser blower connector from harness connector.
- c. Remove 4 each screws attaching condenser blower assembly to the exhaust housing.
- d. Remove blower lower support bracket attached to the exhaust duct tray.
- e. Remove blower assembly.

Replacement

- a. Position condenser blower and install attaching hardware and lower support bracket.
- b. Re-connect blower electrical plug to harness socket.
- c. Install condenser assembly cover panel to condenser assembly.

**11. Removal and Replacement of Compressor Drive Belt (Figure 4-3 & 4-4)**

**NOTE**

Generally, AS350 Single Hydraulic configured helicopters (and Dual Hydraulic built before 2003) use the Flat belt compressors. Dual Hydraulic configured helicopters (Aircraft built after 2003) use the Poly V belt compressor.

Removal

- a. Cut safety wire on compressor belt tensioning link and belt tensioning link jam nuts, and loosen respective jam nut(s).
- b. Loosen upper and lower compressor pivot bolts and lower link assembly mounting bolt on the compressor mount to allow freedom of movement of compressor.
- c. Adjust belt tensioning link to loosen drive belt.

- d. Refer to Airbus Model AS350 Maintenance Manual for removal of main gearbox engine coupling to gain access to the hydraulic pump/compressor drive pulley on the main rotor input shaft. Remove drive belt.

Replacement

**NOTE**

A second belt should be pre-installed on the main rotor input shaft housing as a spare.

**NOTE**

Flat belts must be installed so that the direction of travel conforms to the marking on the belt.

- a. Install drive belt on compressor pulley and drive pulley.
- b. Adjust drive belt tension according to adjustment procedure below.
- c. Tighten and torque upper and lower compressor pivot bolt/nut and lower link assembly mounting bolt/nut on the compressor mount to torque values in Figure 7-4.

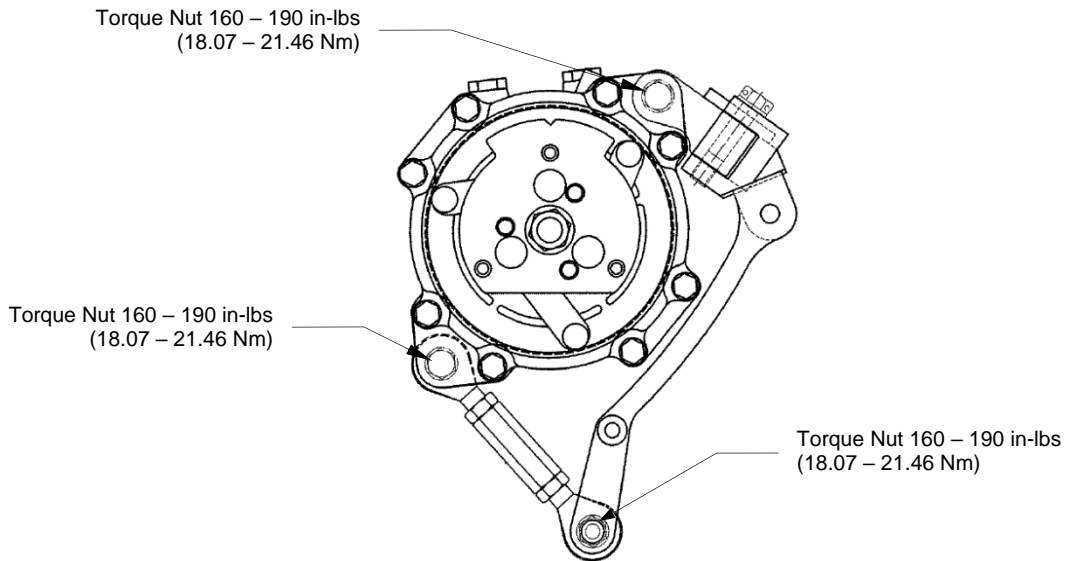

**Figure 7-4 – Compressor Mount Fasteners Torque Values (Flat & Poly V Belt)**

## 12. Adjustment of Compressor Drive Belt

### NOTE

Proper static belt tension (and alignment for Flat belt) is necessary to insure proper belt life and to avoid excessive side load on the M/R input shaft. The belt tension should be reset after several hours of operation for a new belt.

- a. Ensure compressor mount fasteners are tightened and properly torqued.
- b. Apply appropriate force as per Figures 7-5 or 7-6 depending on belt configuration using a tension tester midpoint of belt span between the compressor pulley and the drive pulley.
- c. Deviation should be as per Figures 7-5 or 7-6 depending on belt configuration.
- d. Cut safety wire on compressor belt tensioning link and belt tensioning link jam nuts, and loosen respective jam nut(s). Adjust belt tensioning link as required.
- e. (Flat belt only – Poly V belt proceed to step i.) Hand turn tail rotor and verify belt tracks in the center of the pulley. Premature belt failure will occur if belt rides on fence of pulley in service. If belt tracks in the center proceed to step g.
- f. To adjust tracking, loosen AN4H5A Bolt. Adjust 412AC-3016-16 Bolt as follows (Figure 7-7):
  - a. Turn CW to make belt track more aft on the pulley.
  - b. Turn CCW to make belt track more forward on the pulley.
  - c. Re-tighten AN4H5A Bolt on mount and tighten NAS509-8 Check Nut.
 Repeat step e.
- g. Run helicopter up to full RPM and engage compressor. Monitor belt until tracking shifts to fence of pulley (this could take several minutes). Belt has stretched and needs to be re-tensioned (tracking adjustment may not be necessary).
- h. Re-peat steps e through g.
- i. Tighten and safety wire compressor belt tensioning link and jam nuts.

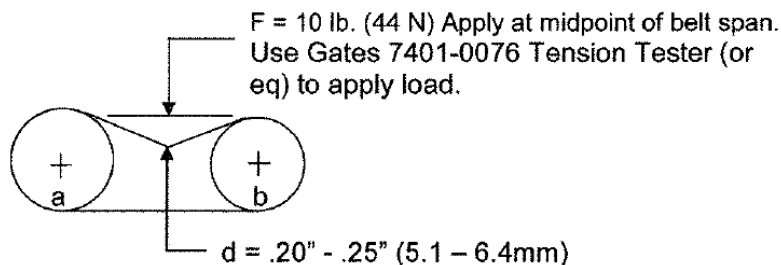

Figure 7-5 – Flat Belt Adjustment Value

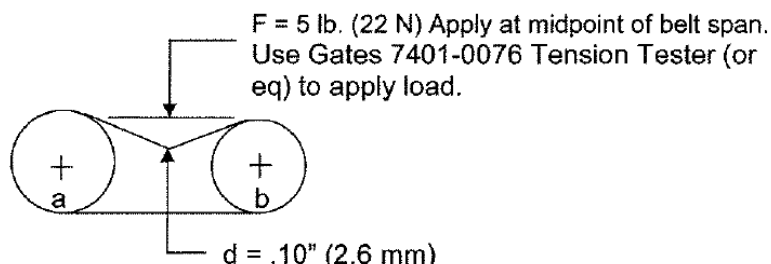

Figure 7-6 – Poly V Belt Adjustment Value

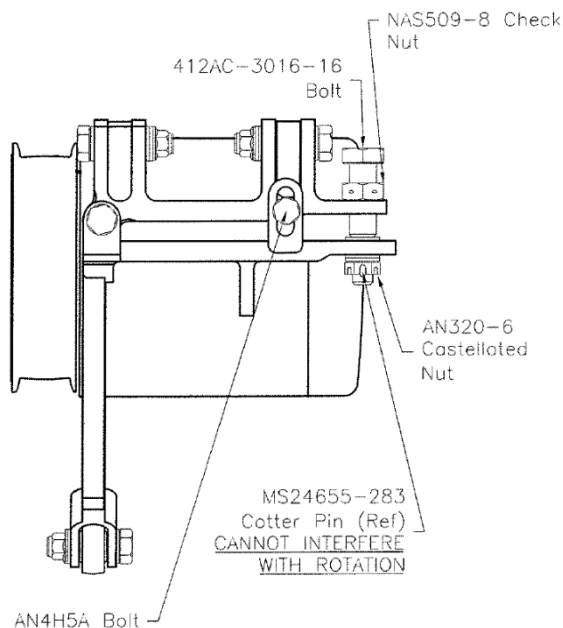

Figure 7-7 – Flat Belt Alignment

### **13. Removal and Replacement of Compressor Assembly (Figure 4-3 & 4-4)**

#### Removal

- a. Disconnect refrigerant plumbing from compressor fittings once refrigerant is evacuated. Always use a back-up wrench.
- b. Cut safety wire on compressor belt tensioning link and belt tensioning link jam nuts, and loosen respective jam nut(s).
- c. Loosen upper and lower compressor pivot bolts on the compressor mount to allow freedom of movement of compressor.
- d. Adjust belt tensioning link to loosen drive belt. Remove belt from compressor pulley.
- e. Remove nut and bolt from upper and lower compressor mounts while supporting compressor. Remove compressor.

#### Replacement

Calculating and measuring the lubricant in the new compressor:  
 The amount of oil in the replacement compressor needs to be adjusted to match the amount of oil in the old compressor. To properly calculate the amount of oil required in the replacement compressor, it is necessary to pour the oil out of the old compressor into a clean container. Drain the oil out of the fill plug hole and then pour oil out of the suction and discharge ports while rotating the center shaft clockwise. Measure the total amount of oil removed from the old compressor. Note that the compressor (new

or old) retains .5 oz. of unrecoverable oil even after completely draining. This total is what is needed to be in the new compressor. New compressors come from Air Comm charged with 8.0 oz. of oil. This should be adjusted according to the amount of oil recovered from the old compressor and any other components being replaced. The receiver drier should always be replaced when the compressor is replaced or when the system has been open for an appreciable time, which accounts for another 1.5 oz. of oil that should be added.

Below is an example of a compressor (and receiver drier) replacement oil calculation for illustration:

Evacuating the system recovers 1.5 oz. of oil. Draining the old compressor recovered 2.0 oz. of oil. The new receiver/drier requires an additional 1.5 oz. so the total oil needed in the replacement compressor for this case is  $1.5 + 2.0 + 1.5 = 5.0$  oz, plus the .5 oz of unrecoverable oil for a total of 5.5 oz. Since the new compressor comes with 8.0 oz. of oil, remove the oil fill plug and pour out 2.5 oz. of oil.

- a. Position compressor and install upper and lower nut and bolt on compressor mount. Do not tighten.
- b. Install belt on compressor pulley.
- c. Perform belt adjustment according to procedure in paragraph 10.
- d. Tighten and torque mounting bolts to torque values in Figure 7-4.
- e. Replace all O-rings before connecting refrigerant plumbing to compressor fittings using a back-up wrench. Torque refrigerant line connections per section 2, p.36.
- f. Service air conditioning system with refrigerant per Chapter 6, p.30.

### **14. Removal and Replacement of Receiver Drier Bottle** **(Figure 4-11)**

#### **NOTE**

For the tail boom mounted condenser option only, the drier bottle is accessed through the right side baggage compartment.

#### **Removal**

- a. Disconnect refrigerant plumbing from receiver drier bottle fittings once refrigerant is evacuated. Always use a back-up wrench.
- b. Loosen clamp securing receiver drier bottle. Remove receiver drier.

#### **Replacement**

#### **CAUTION**

Replacement receiver drier bottles are capped to prevent moisture contamination. Receiver drier bottles left uncapped and open for more than 10 minutes must be discarded and replaced.

- a. Install receiver drier bottle and tighten clamp.



- b. Replace all O-rings before connecting refrigerant plumbing to receiver drier bottle fittings using a back-up wrench. Torque refrigerant line connections per section 2, p.36.
- c. Service air conditioning system with refrigerant per Chapter 6, p.30.

## **15. Removal and Replacement of Bypass Valve** **(Figure 4-15)**

### Removal

- a. Disconnect refrigerant plumbing from bypass valve once refrigerant is evacuated. Always use a back-up wrench.
- b. Disconnect electrical wiring from bypass valve solenoid.
- c. Remove attaching hardware to mounting brackets securing bypass valve. Remove bypass valve.

### Replacement

- a. Install bypass valve and secure to mounting brackets with attaching hardware.
- b. Replace all O-rings before connecting refrigerant plumbing to bypass valve fittings using a back-up wrench. Torque refrigerant line connections per section 2, p.36.
- c. Connect electrical wiring to bypass valve solenoid. Secure wiring as needed.
- d. Service air conditioning system with refrigerant per Chapter 6, p.30.

## **16. Removal and Replacement of Binary Switch** **(Figure 4-10)**

### Removal

- a. Access the switch located on the refrigerant line attaching to the aft evaporator. Note that it is not necessary to discharge the refrigerant for this servicing operation.
- b. Disconnect the electrical wiring from the binary switch.
- c. Remove the binary switch by unscrewing it from the Schrader valve on the tube assembly.

### Replacement

- a. Install the binary switch.
- b. Connect the electrical wiring to the binary switch.

**17. Removal and Replacement of Condenser Fan EMI Filters (Tail Boom Condenser Model)**

Removal

- a. Disconnect aircraft battery and any ground power sources from the aircraft.
- b. Remove access panel on tail boom condenser housing to access the EMI filters located within the assembly.
- c. Disconnect the electrical wiring from the EMI filter.
- d. Remove screws mounting the EMI filter to the condenser housing and remove EMI filter.

Replacement

- a. Install new EMI Filter with mounting screws.
- b. Connect the filter connectors to the aircraft wiring and condenser blower wiring. The connectors are keyed and can only be connected in one way. Secure wiring as necessary.
- c. Reinstall access panel cover and reconnect aircraft battery.

**18. Removal and Replacement of Pressure Relief Valve**

Removal

- a. Locate the pressure relief valve on the Y fitting adjacent to the receiver-dryer bottle below the right side equipment bay.
- b. Evacuate refrigerant from the system.
- c. Remove the pressure relief valve.

Replacement

- a. Place a small amount of refrigerant oil on the o-ring and install the valve.
- b. Re-charge the system per chapter 6, p.30.

**CHAPTER 8**  
**TROUBLESHOOTING**

**1. System Troubleshooting**

Prior to troubleshooting a defective system, it is advisable to conduct a visual inspection for general condition and obvious signs of damage or failure.

The following matrix lists the easiest checks and the most likely problems.

<b>Problem</b>	<b>Probable Cause</b>	<b>Corrective Action</b>
System not Cooling (Evaporator blowers still operating)	System is low or empty of refrigerant	Evacuate the system, determine the origin of the refrigerant leak if applicable, and re-charge the system
	Moisture or air in the system	Evacuate the system, replace the receiver drier, and place the system under a vacuum for a minimum of 45 minutes before recharging the system
	Compressor	If the compressor has failed, it must be replaced
	Compressor drive belt	If the compressor drive belt has failed it will need to be replaced
	Bypass valve	Check to insure the temperature control knob on the A/C control panel in the cockpit is in the full cold position, and the temperature control circuit breaker has not tripped. If the valve remains open (by-passing refrigerant) the valve will need replacement
	Condenser blower motor / fan assembly.	Check to insure the condenser blower motor/fan assembly are receiving power, and the circuit breakers have not tripped; if the blowers still do not function, they may have failed internally and must be replaced
System not cooling (Evaporator blowers not operating)	Air conditioner control circuit breaker tripped.	Reset circuit breaker; if breaker will not reset, check for short in circuit
	Forward or Aft evaporator blower circuit breaker tripped.	Reset circuit breaker; if breaker will not reset, check for short in circuit.

## AIR CONDITIONER SERVICE MANUAL AS350-200M-1

Problem	Probable Cause	Corrective Action
System not cooling (Evaporator blowers not operating)	Forward and aft evaporator blower motor(s)	Check for power to the motor(s), and for the free movement of the blower wheel; if the motor shaft does not turn smoothly the motor must be replaced
Loss of cooling limited to one evaporator	Expansion valve malfunction	If cooling is lost in only one of the evaporators, and the blowers continue to function, it is most likely a blockage at the expansion valve orifice, this is most often caused by dirt in the system forming a blockage as the refrigerant passes through the valve; evacuating the system and changing the receiver drier should cure this problem; if the above actions do not resolve the problem, the evaporator assembly must be replaced
External moisture (Condensate) in the area of forward / aft evaporator	Leak in evaporator, or evaporator drainage system	If water is noted in the area near the evaporators, this is normally caused by a loose, cracked, plugged, or disconnected drain line  <b>NOTE</b>  The drain line consists of a tube which extends from the lower surface of the evaporators through the outer contour of the helicopter

(Contact Air Comm Corporation Service Department for current pricing and availability of replacement components and parts)

Figure 8-1 – Electrical Schematic, Side Baggage Mounted Condenser (Tail Boom Condenser Option identical except for additional condenser blower and EMI filters, see insert.)

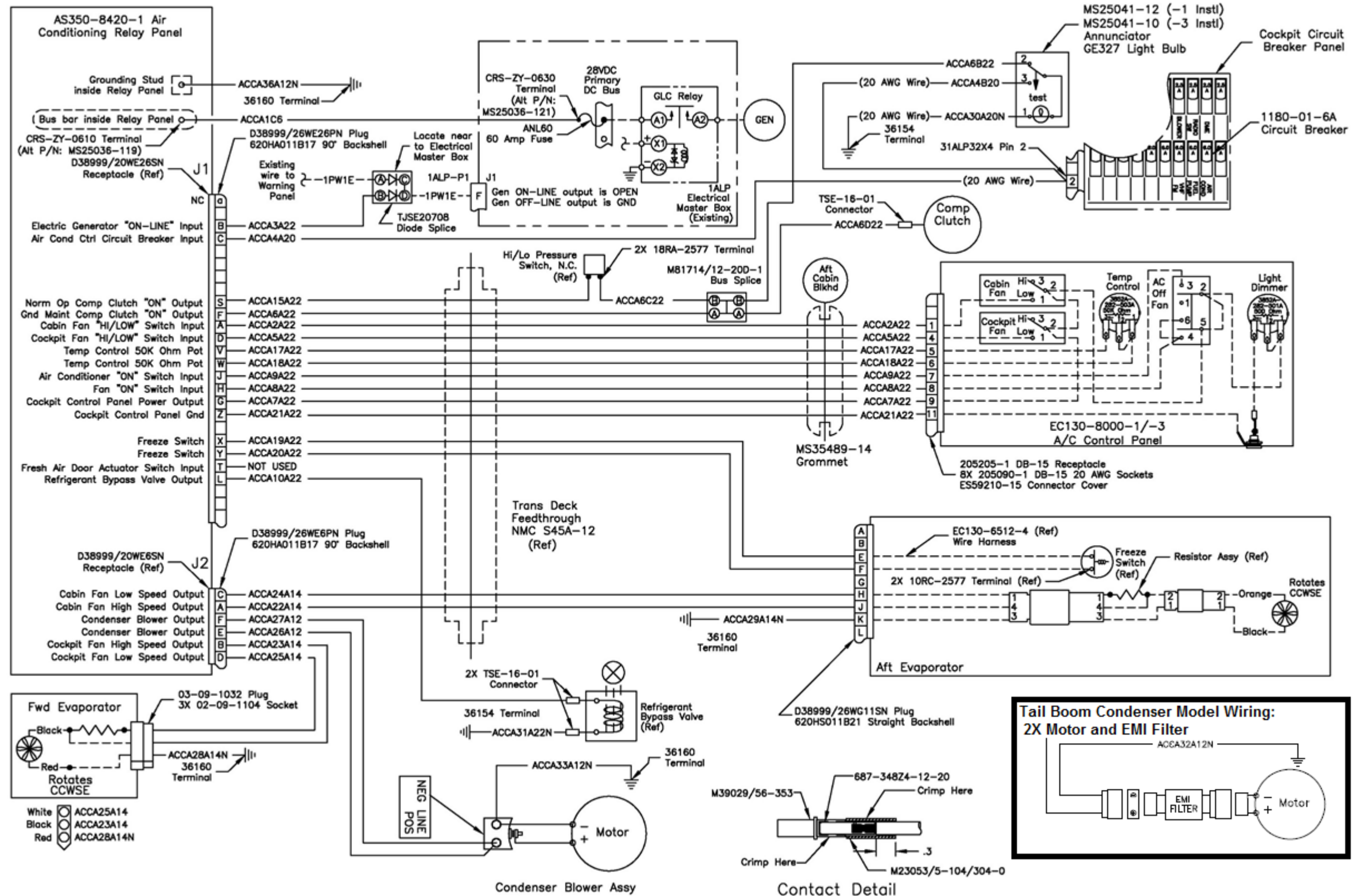
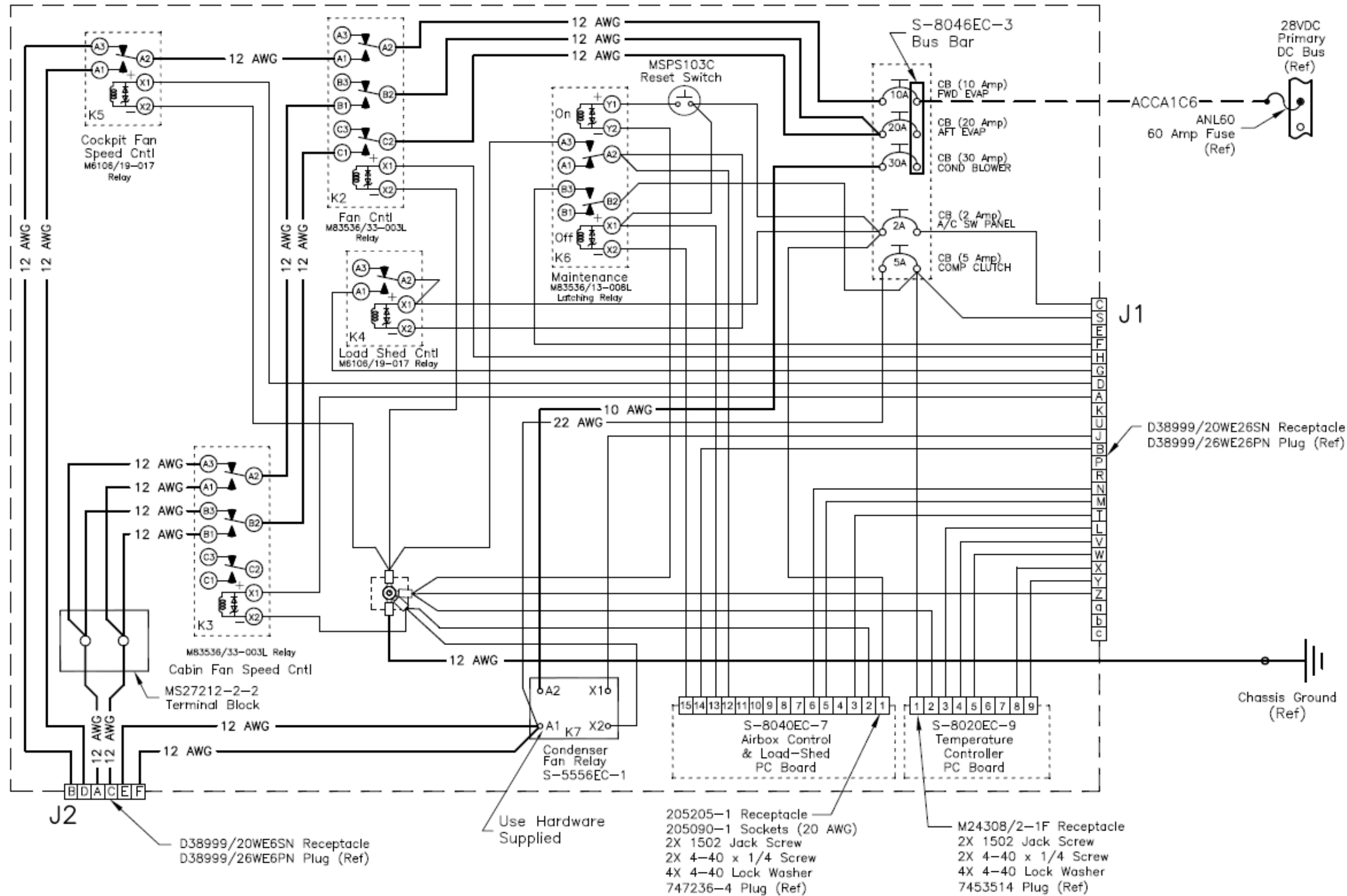

Figure 8-2 – Electrical Schematic, Relay Panel



**APPENDIX A  
WEIGHT AND BALANCE INFORMATION**

Airbus AS350 Air Conditioner System

Ref. Dwg. AS350-200 (Flat Belt Configuration), AS350-202 (Poly-V Belt Configuration)  
or AS350-204 (Tail Boom Condenser Configuration)

<b>Item</b>	<b>Wt. (lbs)</b>	<b>X-Arm (in)</b>	<b>X-M (in-lb.)</b>	<b>Y-Arm (in)</b>	<b>Y-M (in-lb)</b>
AS350 -200, -202 Air Conditioner	94.7	112.3	10,640	13.1	1,245
AS350 -204 Air Conditioner	97.5	141.9	13,839	6.7	654