

DESIGN SPECIFICATIONS	
FLUID	AIR
FLUID TEMP	-65° TO 600°F
FLOW RATE	15 LB/MIN @ 70°F
PRESSURE	20 PSIG (MAX.)
PRESSURE DROP	2.0 PSI @ RATED FLOW
LEAKAGE	.05 LB/MIN @ 15 PSIG AND 70°F TO 80°F AIR
WEIGHT	0.04 LBS ± 20%
CRACKING PRESSURE	1 IN. H2O MAX.

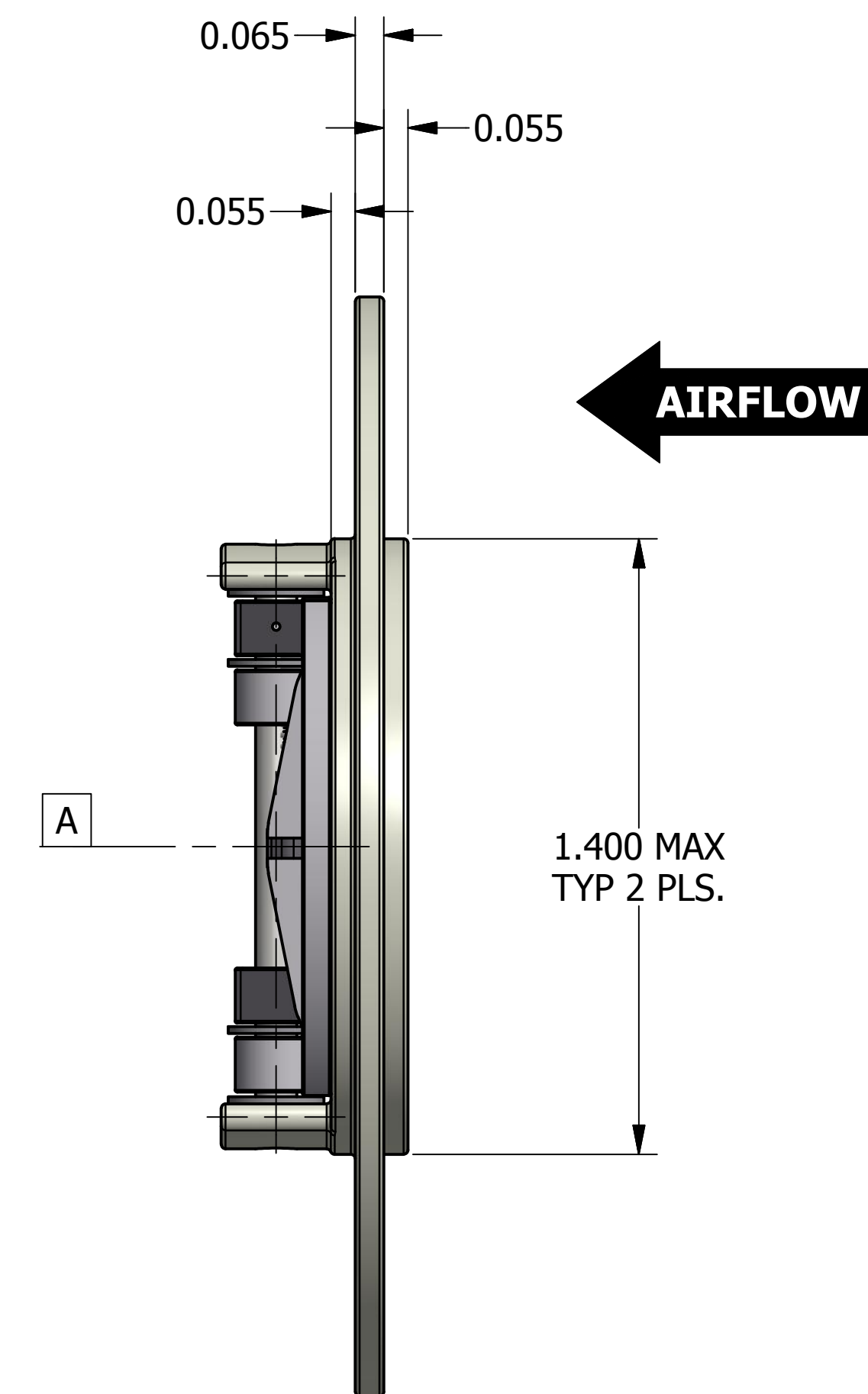
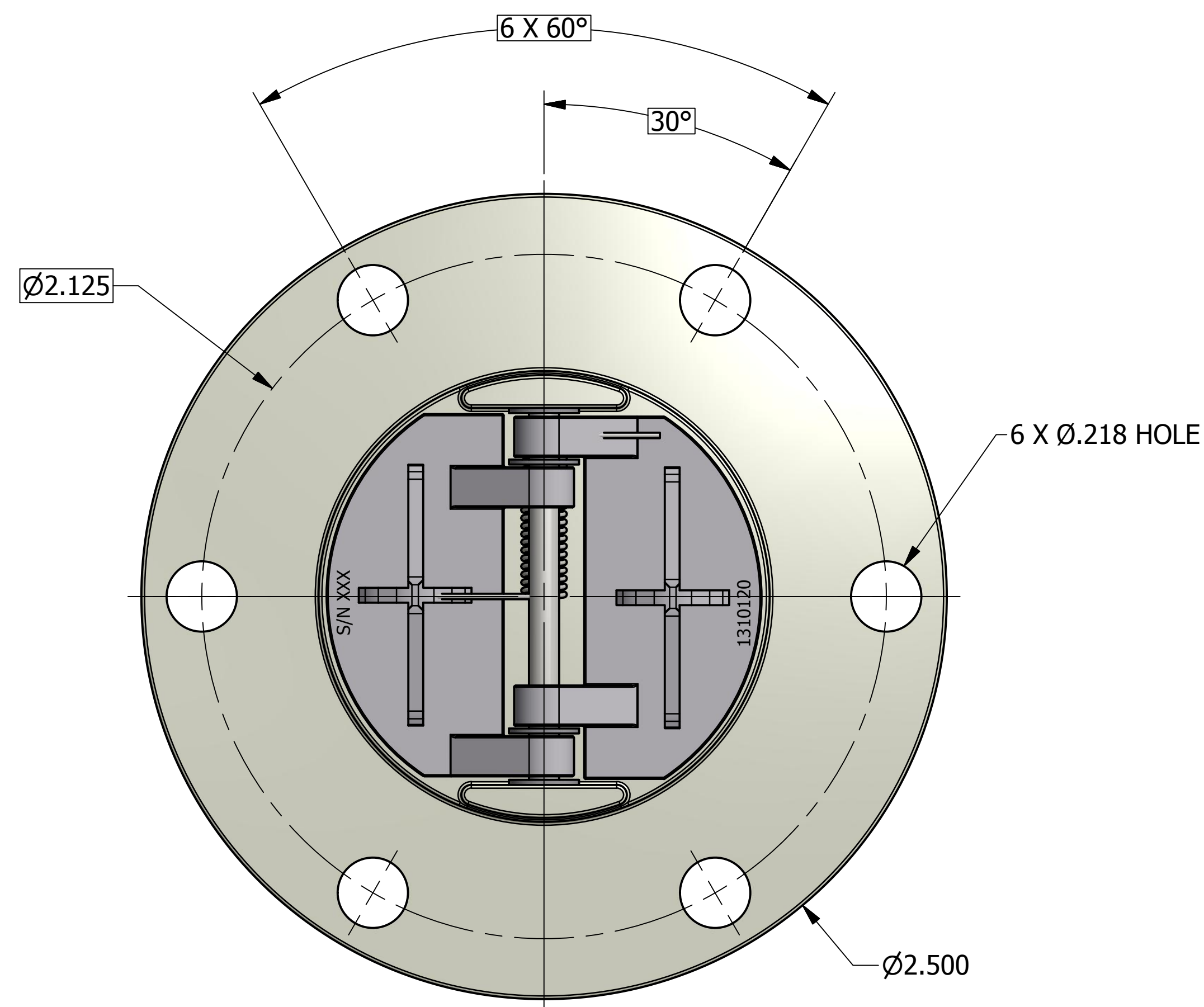

PROPRIETARY NOTICE
THIS DRAWING IS A PART OF THE PROPRIETARY ARTICLE HEREIN DISCLOSED, AND ALL DESIGN, MANUFACTURING, REPRODUCTION, USE, PATENT RIGHTS AND SALES RIGHTS REGARDING THE SAME ARE EXPRESSLY RESERVED BY ENVIRO SYSTEMS, INC. IT IS SUBMITTED UNDER A CONFIDENTIAL RELATIONSHIP FOR A SPECIFIC PURPOSE AND SHALL NOT BE DISCLOSED TO ANY UNAUTHORIZED PERSON, COMPANY, OR INCORPORATED IN ANY OTHER PROJECTS.

ENVIRO SYSTEMS, INC.
SEMINOLE, OKLAHOMA

VALVE ASSY., CHECK

SIZE	CAGE CODE	DRAWING NO.	REV.
D	0B9E8	1310120-CAT	
SCALE:	3:1	WEIGHT:	SHEET 1 OF 1