

DESIGN SPECIFICATIONS

- 1. OPERATING TEMP. _____ -60°F TO 158°F
- 2. ALTITUDE _____ S.L. TO 50K FT.
- 3. BLEED AIR TEMPERATURE _____ 700°F (MAX)
- 4. BLEED AIR PRESSURE _____ 150 PSIG (MAX)
- 5. MAX. FLOW RATE _____ 24.6 LB/MIN @ 120 PSIG
BLD. PRESS., 620°F BLD. TEMP.
& 70°F AMB. TEMP
- 6. VOLTAGE _____ 28VDC
- 7. CURRENT _____ 500mAMPS (MAX)
- 8. WEIGHT _____ 5.37 LBS. (MAX)

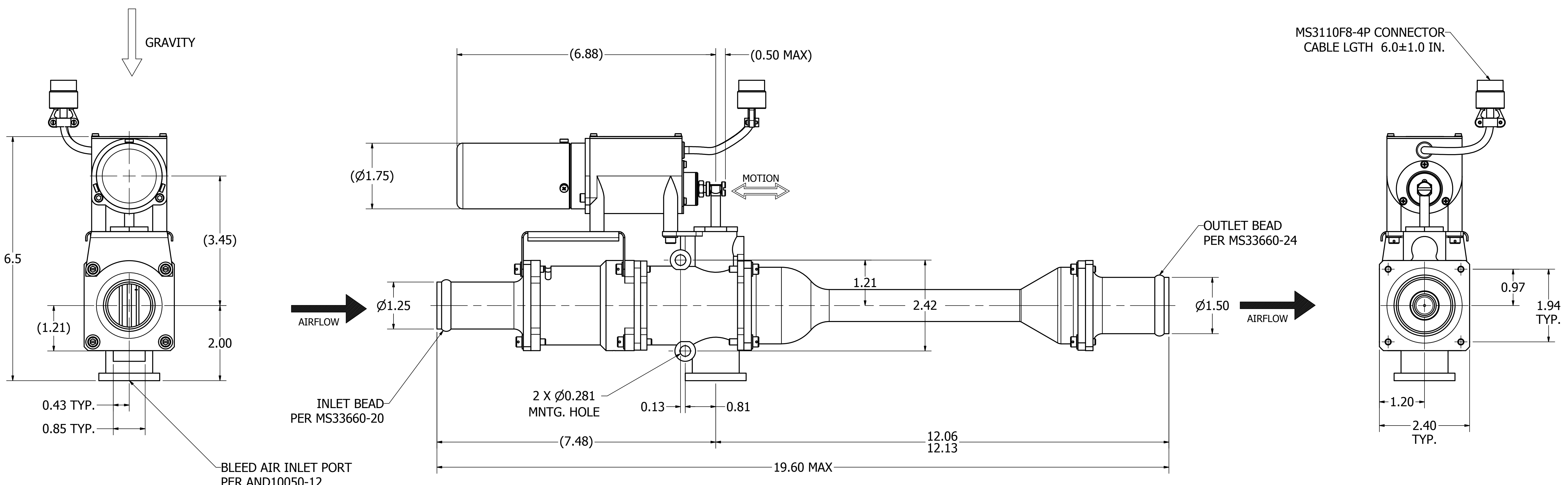

PROPRIETARY NOTICE
 THIS DRAWING IS A PART OF THE PROPRIETARY ARTICLE HEREIN DISCLOSED, AND ALL DESIGN, MANUFACTURING, REPRODUCTION, USE, PATENT RIGHTS AND SALES RIGHTS REGARDING THE SAME ARE EXPRESSLY RESERVED BY ENVIRO SYSTEMS, INC. IT IS SUBMITTED UNDER A CONFIDENTIAL RELATIONSHIP FOR A SPECIFIC PURPOSE AND SHALL NOT BE DISCLOSED TO ANY UNAUTHORIZED PERSON, COMPANY, OR INCORPORATED IN ANY OTHER PROJECTS.

ENVIRO SYSTEMS, INC.
 SEMINOLE, OKLAHOMA

VALVE ASSY., FLOW CONTROL

SIZE	CAGE CODE	DRAWING NO.	REV.
D 0B9E8		1300490-CAT	
SCALE:	3/4	WEIGHT:	SHEET 1 OF 1