

DESIGN SPECIFICATIONS	
3-PHASE 200VAC FREQUENCY RANGE	314 - 413 Hz
AIRFLOW (392.6 HZ)	2200 SCFM
STATIC PRESSURE (392.6 HZ)	2.5" W.G. EXTERNAL TO FAN
PRESSURE	14.696 PSIA [1.01325 BAR]
TEMPERATURE	68 °F [20° C]
VOLTAGE	200 VAC PH-PH - 3 PHASE
SPEED (392.6 HZ)	5,595 RPM
POWER (392.6 HZ)	3.20 KVA 0.5A 28VDC
MAX POWER	3.50 KVA 0.5A 28VDC
WEIGHT	17.5 LBS (MAX.) [7.94 KG]
OPERATING TEMPERATURE	-67°F TO 158°F [-55°C TO 70°C]
SHORT TIME OPERATION / STORAGE	-67°F TO 185°F [-55°C TO 85°C]
ALTITUDE	-1K TO 25K FT

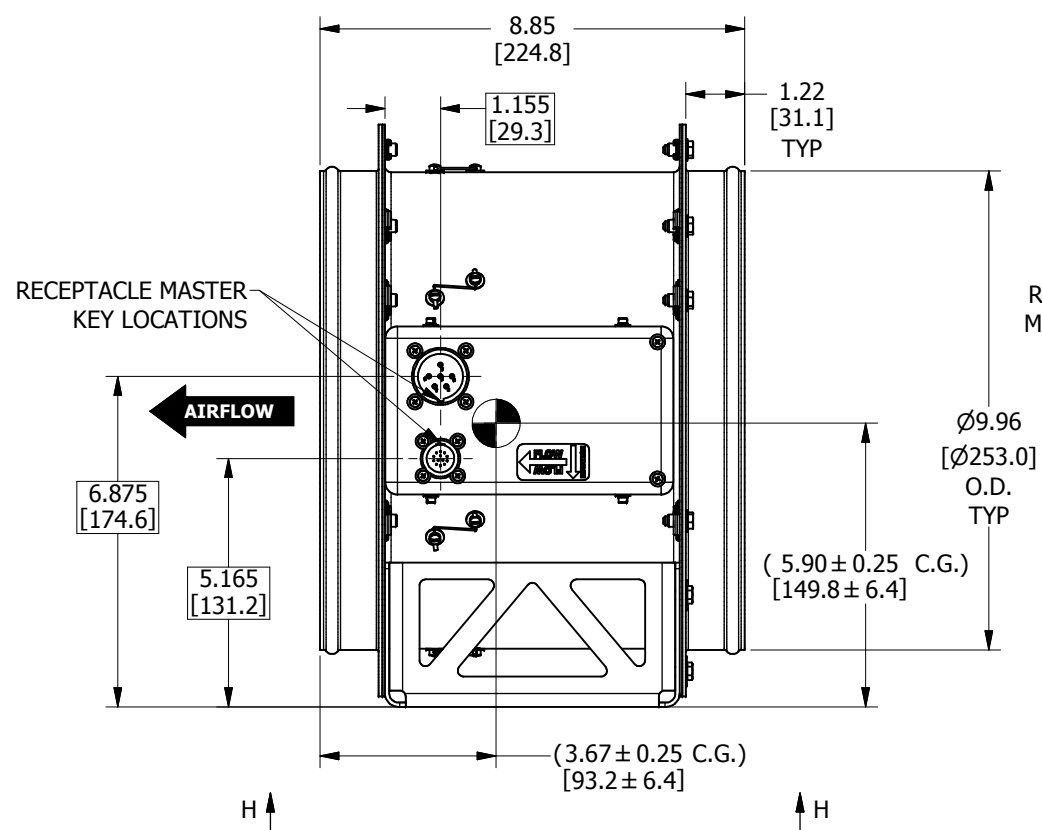
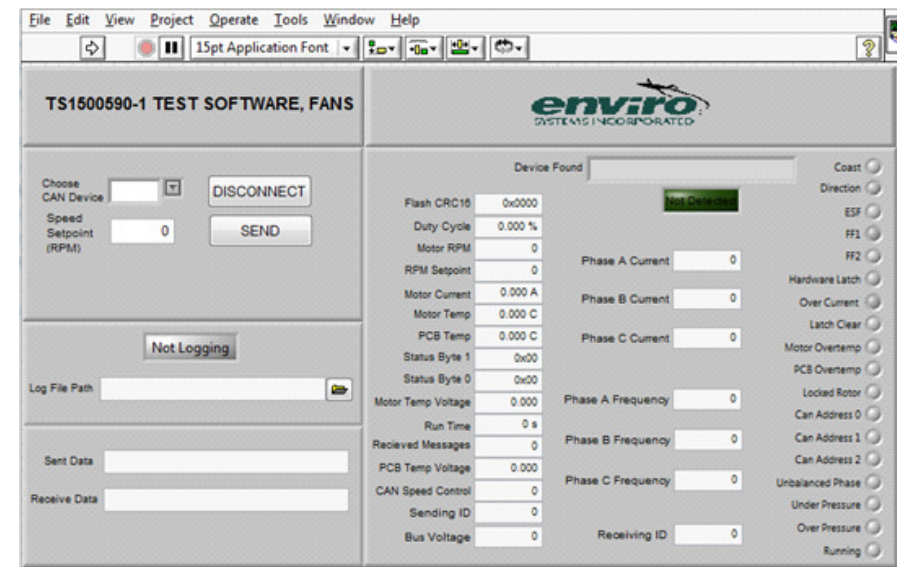

AC FAN CONNECTION
RECEPTACLE D38999/20WE6PN
MATES WITH D38999/26WE6SN
 $\phi .250 BAC$

DC & IO FAN CONNECTION
RECEPTACLE D38999/20WB35PN
MATES WITH D38999/26WB35SN
 $\phi .250 BAC$

(0.50 ± 0.25 C.G.)
[12.7 ± 6.4]

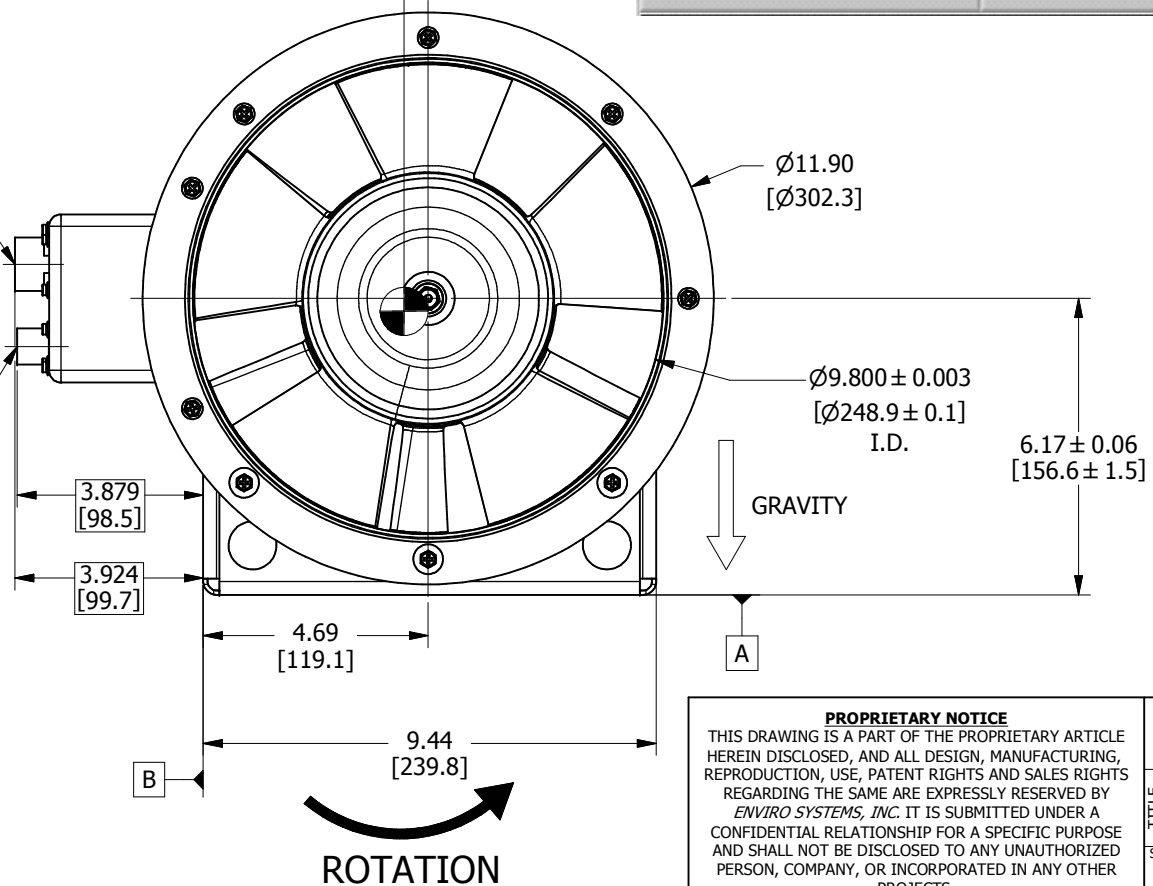

PROPRIETARY NOTICE
THIS DRAWING IS A PART OF THE PROPRIETARY ARTICLE
HEREIN DISCLOSED, AND ALL DESIGN, MANUFACTURING,
REPRODUCTION, USE, PATENT RIGHTS AND SALES RIGHTS
REGARDING THE SAME ARE EXPRESSLY RESERVED BY
ENVIRO SYSTEMS, INC. IT IS SUBMITTED UNDER A
CONFIDENTIAL RELATIONSHIP FOR A SPECIFIC PURPOSE
AND SHALL NOT BE DISCLOSED TO ANY UNAUTHORIZED
PERSON, COMPANY, OR INCORPORATED IN ANY OTHER
PROJECTS.

ENVIRO SYSTEMS, INC.
SEMINOLE, OKLAHOMA

**FAN, CONDENSER,
AXIAL, 9.8 INCH**

SIZE: D 0B9E8 CAGE CODE: 1270980-CAT DRAWING NO.: -
SCALE: 1 : 2 WEIGHT: NOTED SHEET 1 OF 1