

DESIGN SPECIFICATIONS	
AIRFLOW (HIGH SPEED)	200 CFM
STATIC PRESSURE (H.S.)	1.5" W.G. EXTERNAL
PRESSURE	14.696 PSIA [1.01325 BAR]
AIR INLET TEMPERATURE	80°F (D.B.) & 67°F (W.B.)
VOLTAGE	28.0 VDC (NOM.)
HIGH SPEED	5,100 RPM
HIGH SPEED CURRENT	15.0 AMPS MAX
WEIGHT	5.75 LBS (MAX.) [2.61 KG MAX]
OPERATING TEMPERATURE	5°F TO 158°F [-15°C TO 70°C]
SHORT-TIME OPERATION TEMP.	-40°F TO 158°F [-40°C TO 70°C]
STORAGE TEMP.	-67°F TO 185°F [-55°C TO 85°C]
ALTITUDE	-1K TO 15K FT

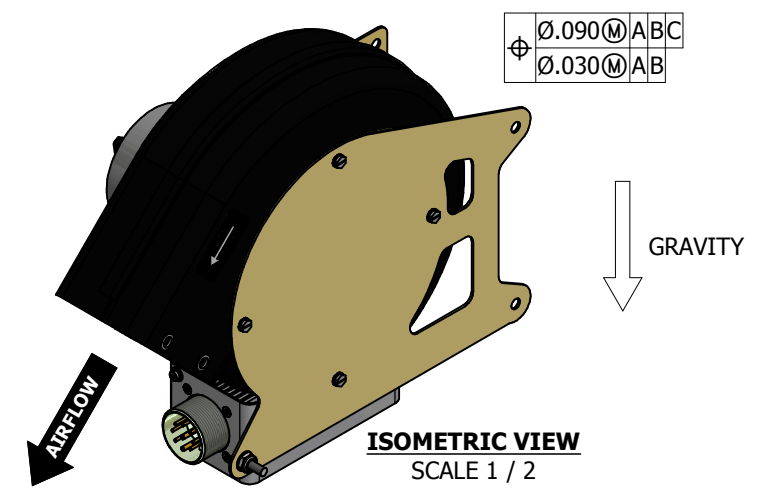
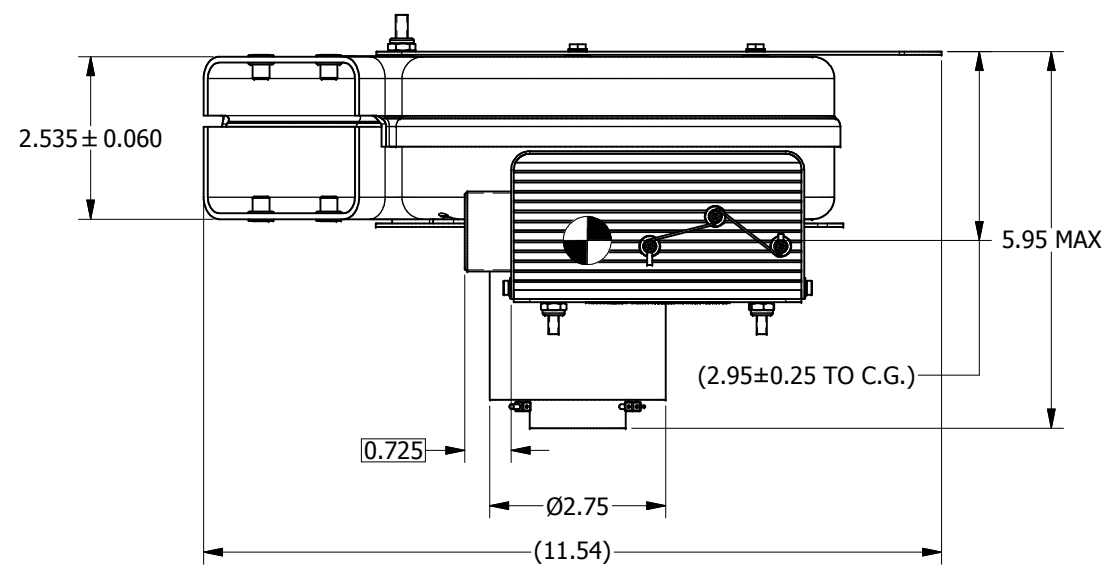

**PROPRIETARY NOTICE**  
THIS DRAWING IS A PART OF THE PROPRIETARY ARTICLE HEREIN DISCLOSED, AND ALL DESIGN, MANUFACTURING, REPRODUCTION, USE, PATENT RIGHTS AND SALES RIGHTS REGARDING THE SAME ARE EXPRESSLY RESERVED BY ENVIRO SYSTEMS, INC. IT IS SUBMITTED UNDER A CONFIDENTIAL RELATIONSHIP FOR A SPECIFIC PURPOSE AND SHALL NOT BE DISCLOSED TO ANY UNAUTHORIZED PERSON, COMPANY, OR INCORPORATED IN ANY OTHER PROJECTS.

**ENVIRO SYSTEMS, INC.**  
SEMINOLE, OKLAHOMA

**ASSY., MOTOR**

SIZE: D 0B9E8 CAGE CODE: 1133320-CAT DRAWING NO.: 1133320-CAT

SCALE: 2 / 3 WEIGHT: SHEET 1 OF 1